

FBs-RTD6

6 Channel RTD Temperature Input Module



Introduction

FBs-RTD6 is one of the temperature input modules of FATEK FBs series PLC. It provides 6 channels of RTD temperature measurement input with 0.1 °C or 1 °C resolution. The scan rate for 0.1 °C resolution is 2 seconds, while the scan rate for 1 °C resolution is 1 second. This module provides three-wire connection for RTD temperature sensor, thus can automatically compensate the resistance introduced by the wiring. All the optional features of this module are software configurable, there are no hardware jumpers or switches for user to setup.

Dimensions

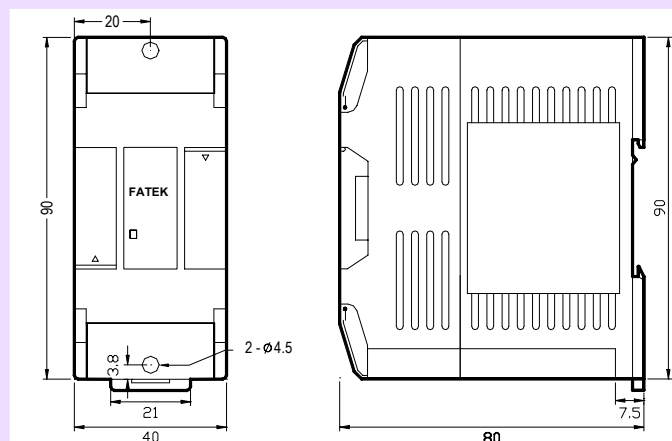

Specifications

Total Channels - 6 CH

Resolution- 0.1 °C or 1 °C

I/O Points Occupied –

1 RI(Input Register)

8 Discrete Output(DO)

Conversion Time- 1 or 2 Seconds

Accuracy- ±1 %

Sensor Type- Pt-100, Pt1000 (JIS or DIN)

Software Filter- Moving average

Average Samples- 1,2,4,8,16 configurable

Measurement Range-

Pt100: -200~850°C

Pt1000: -200~600°C

Isolation- Transformer(Power) and photo-coupler(Signal)

Indicator(s) – 5V PWR LED

Supply Power- 24V-15%/+20%, 2VA

Internal Power Consumption- 5V, 35mA

Operating Temperature- 0 ~ 60 °C

Storage Temperature- -20 ~ 80 °C

Dimensions- 40(W)x90(H)x80(D) mm



PLCs



Acquisition



Instruments



Data logger



Power



HMIs

1/1



Switches



Motion



Sensors



Converters



Keyboards



SCADA

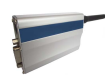

Telemetry

FBs-RTD6

6 Channel RTD Temperature Input Module

Wiring Diagram

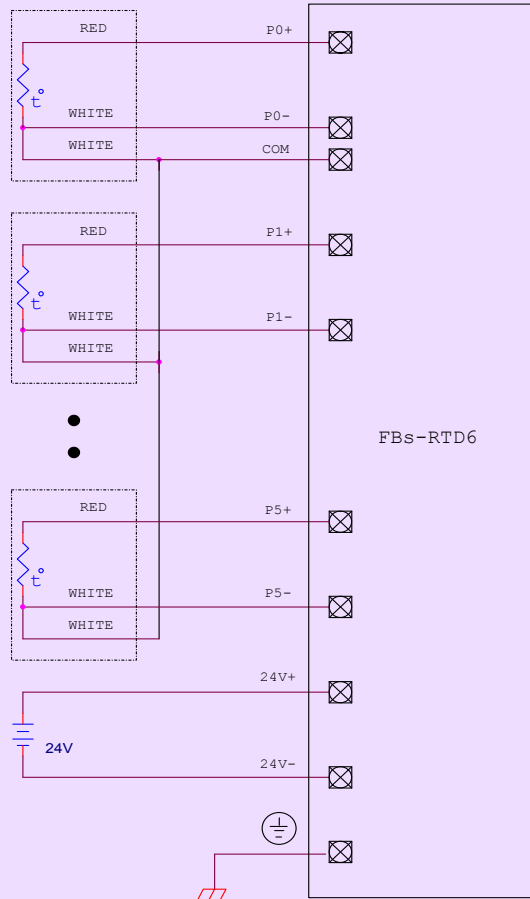

PLCs



Acquisition



Instruments



Data logger



Power



HMIs



Switches



Motion



Sensors



Converters



Keyboards



SCADA



Telemetry

I/O Configuration

Before the temperature value can be retrieved, the user should perform the I/O configuration of temperature module with the help of Winproladder software. The following screen will be shown when perform the I/O configuration

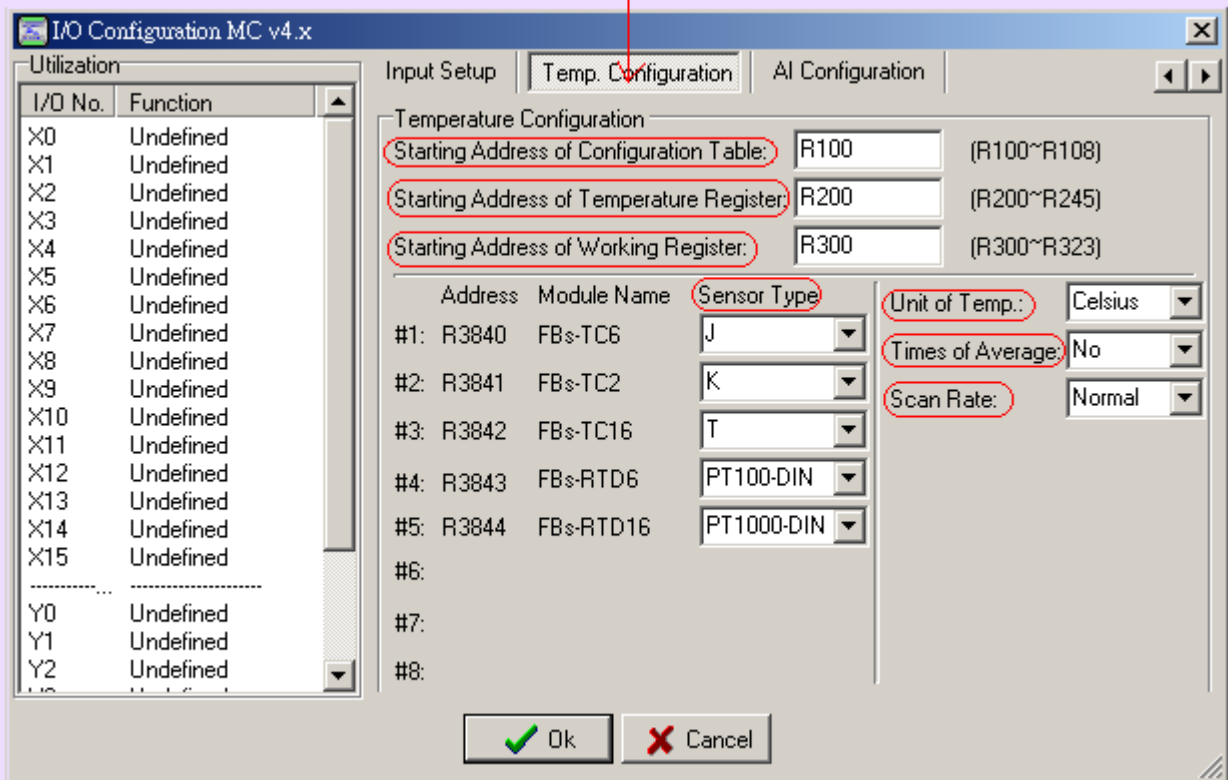

The user need to assign a starting register of a contiguous register area for holding temperature reading value and areas for storing the configuration table and working scratchpad and define the sensor type, unit of temperature, scan speed and samples for average. Please refer the advanced manual II for detail explanation.



PLCs



Acquisition



Instruments



Data logger



Power



HMIs

3/3



Switches



Motion



Sensors



Converters



Keyboards

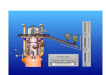

SCADA



Telemetry