

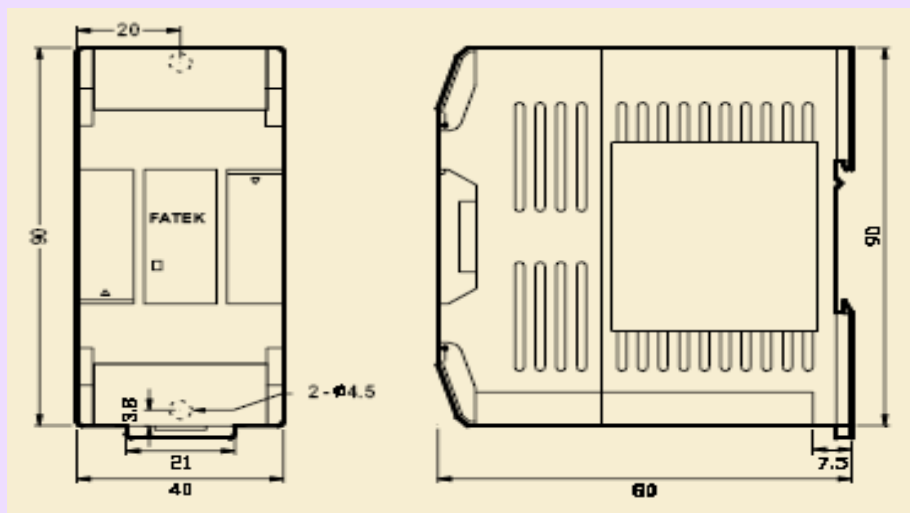

Introduction

FBS-1LC is one of the analog input modules of FBS series PLC. It can connect one load cell input for weight measurement. The conversion result is represented by a signed 16 bit integer value. In order to filter out the field noise imposed on the signal, it also provides the average of sample input function.

Dimensions



Specifications

- Total Channels** - One channel
- Resolution**- 16 bit (include signed bit)
- I/O Points Occupied** - 1 RI(Input Register) and 8 DO
- Conversion Rate**- 5/10/20/25 Hz selectable
- Non-Linearity**- 0.01% F.S. (@25°C)
- Zero Drift**- 0.2 $\mu\text{V}/^\circ\text{C}$
- Gain Drift**- 10 ppm/ $^\circ\text{C}$
- Excitation Voltage** – 5V with 250 Ω load
- Sensitivity** - 2mV/V, 5mV/V, 10mV/V, 20mV/V
- Software Filter**- Moving average
- Average Samples**- 1~8 configurable
- Isolation**- Transformer(Power) and photo-coupler(Signal)
- Indicator(s)** - 5V PWR LED
- Supply Power**- 24V-15%/+20%, 2VA
- Internal Power Consumption**- 5V, 100mA
- Operating Temperature**- 0 ~ 60 $^\circ\text{C}$
- Storage Temperature**- -20 ~ 80 $^\circ\text{C}$
- Dimensions**- 40(W)x90(H)x80(D) mm

Wiring Diagram

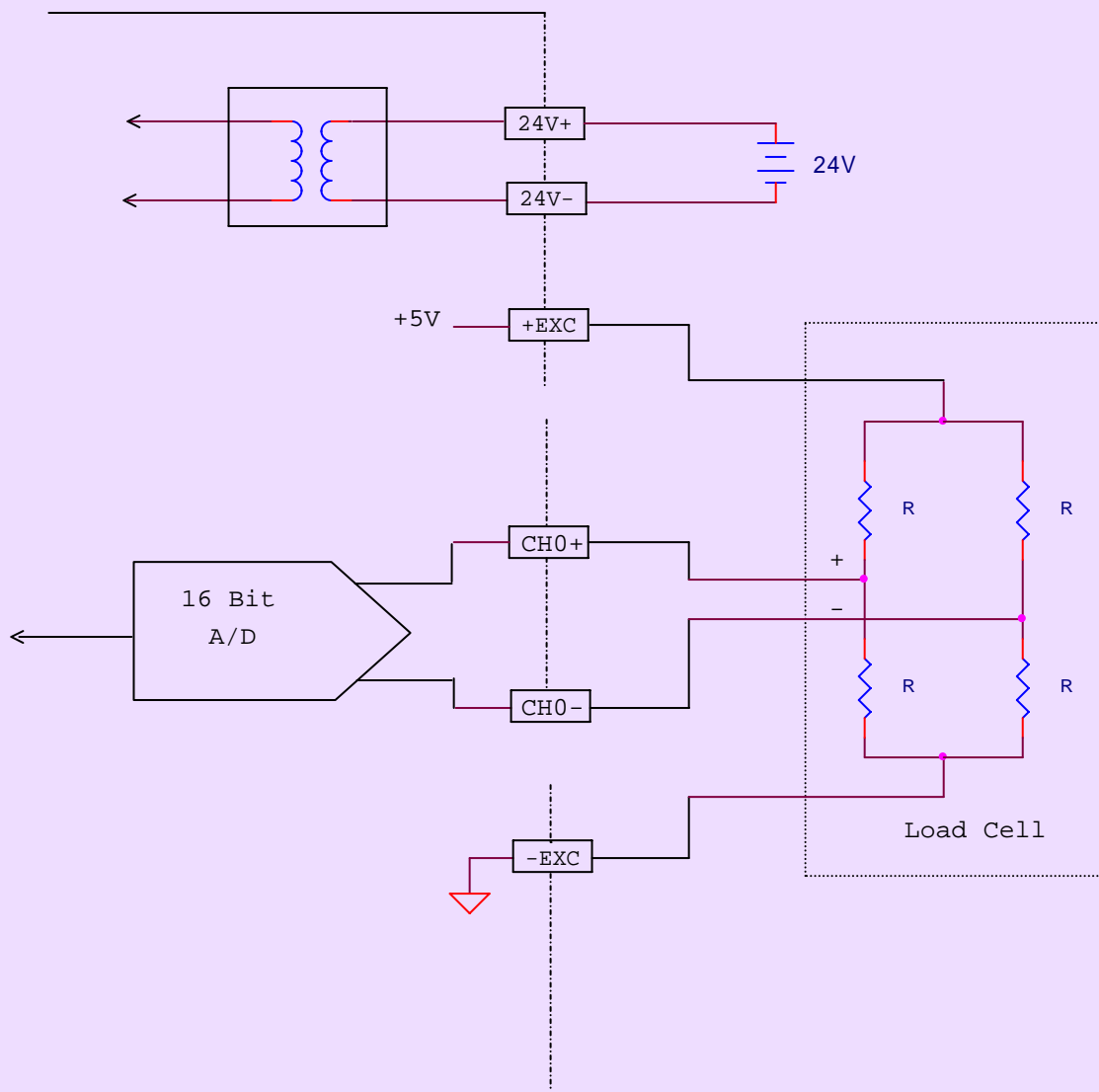

The conversion result is represented by a 16 bit signed value, there should put an additional LCNV (FCN33) or MLC(FCN34) function instruction in the ladder diagram, which will convert the raw reading value into the desire weight value. Because the measurement signal is quite small, for common practice, manual zero adjustment is required in order to overcome the null drift.

PLC Control

The interface between PLC and 1LC module is thru 8 Pts. Of DO and one input register (RI). Thru the control of DO signal, the user can select the conversion rate, operating range and samples for average. Detail description of DO is listed at below. Y_s is the starting number of DO allocated for this module. The conversion result is carried in RI with 16 bit signed format.

Signal	Name	Function Description	
Y_{s+1}, Y_{s+0}	SPAN	00	0~10mV(2mV/V)
		01	0~25mV(5mV/V)
		10	0~50mV(10mV/V)
		11	0~100mV(20mV/V)
Y_{s+3}, Y_{s+2}	RESERVED	Reserved	
Y_{s+5}, Y_{s+4}	CONVSERSION RATE	00	5Hz
		01	10Hz
		10	20Hz
		11	25Hz
Y_{s+7}, Y_{s+6}	AVERAGE COUNT	00	No Average
		01	2 Samples
		10	4 Samples
		11	8 Samples