

MODEL ZCO940
ITEM # FSH03320

Drawing Number: FI1312-C

INCH [mm]



Your Automation Site !

CONNECTOR PLUG KIT
FOR USB MODULES

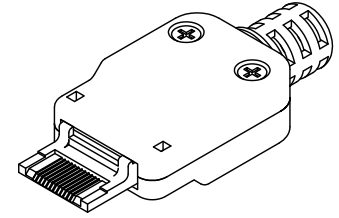

BUSHING

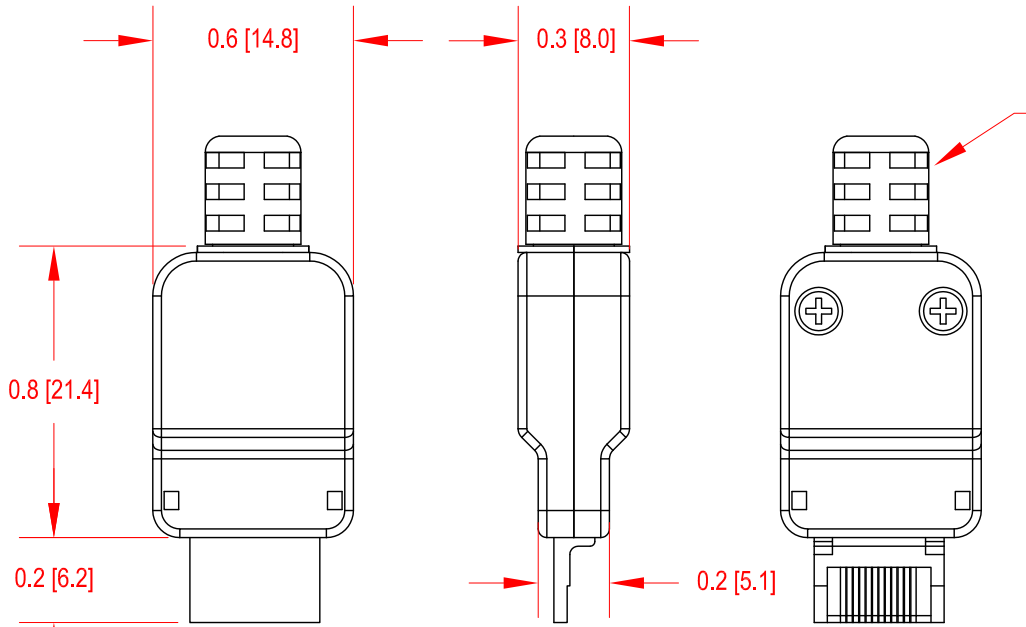

BUSHING SIZES
0.16 [4.0]
0.18 [4.5]
0.20 [5.0]

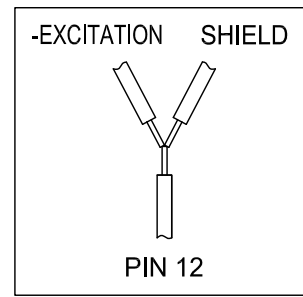
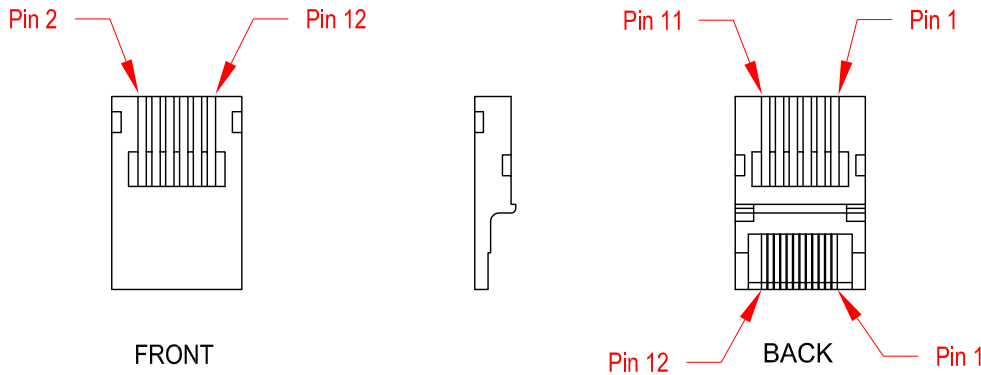

HIROSE MALE (SENSOR SIDE)						
PIN #	USB210/220/230 (FSH03631) USB320 4 WIRE VOLTAGE	USB240	(FSH03631) USB320 3 WIRE VOLTAGE	(FSH03634) USB320 3 WIRE CURRENT	(FSH03634) USB320 2 WIRE CURRENT	USB410
1	+SIGNAL	+SIGNAL 1	+SIGNAL	+SIGNAL	+SIGNAL	+SIGNAL
2	-SIGNAL	-SIGNAL 1	N/A	N/A	N/A	-SIGNAL
5	N/A	+SIGNAL 2	N/A	N/A	N/A	P1- LEADING PULSE
6	N/A	-SIGNAL 2	N/A	N/A	N/A	P2- LAGGING PULSE
9	N/A	+SIGNAL 3	N/A	N/A	N/A	N/A
10	N/A	-SIGNAL 3	N/A	N/A	N/A	N/A
11	+EXC	+EXC	+EXC	+EXC	+EXC	VCC/+EXC
12	-EXC/ SHIELD*	-EXC/ SHIELD*	-EXC/ SHIELD*	-EXC/ SHIELD*	N/A	GND/-EXC/ SHIELD*

*USE Y CONNECTION ON PIN 12 TO MAKE CONNECTING THE -EXCITATION AND SHIELD EASIER

