

**FATEK®**

Since 1992



**Economical and High-Quality PLC**  
**FATEK B1/B1z Series Micro-Programmable Controllers**



TEL : +52 333854 5975  
E-mail : [ventas@logicbus.com](mailto:ventas@logicbus.com)  
[sopORTE@logicbus.com](mailto:sopORTE@logicbus.com)

Website : [www.logicbus.com.mx](http://www.logicbus.com.mx)

[www.logicbus.com.mx](http://www.logicbus.com.mx)

# Be impressed with the high quality!

## Features

### Core Technology of the Advanced SoC

With advanced software, hardware techniques and over 20 years experience in the automation industry, FATEK has integrated its own SoC CPU (Systems on Chip), hardware logic solver (HLS), hardware high-speed counter/timer, NC positioning, communication, FLASH, and SRAM into a tiny BGA chip. This is an industry first making FATEK a market leader in micro PLC design!

### Compact and Rugged

Common components are now integrated into the SoC, so the processor and I/O board layer can now be manufactured on a single PCB substantially reducing the overall size and increasing the reliability of the B1/B1z series controllers!

### High Quality and High Reliability

With the streamline hardware design and the highly integrated SoC technology, the quantity of the components required in the B1/B1z

series PLC is significantly reduced. With the combination of the high quality parts rigorous quality control procedures, FATEK creates a high quality PLC for today's industry.

### Competitive Low Price

The streamline design of SoC technology significantly reduces the hardware costs. The B1/B1z series PLC incorporates the most sophisticated manufacturing process and high quality two-layer board design, and have better noise immunity than other four-layer PLC board design. This makes the B1/B1z PLC very price-competitive in today's cost-conscious PLC market!

### Easy to Use, Common Instruction Sets

The B1/B1z series PLC is an economic type PLC without any compromise to its performance. It also provides all the easy to use yet powerful FBs series PLC's instructions. Both B1/B1z and FBs series PLC are programmed by the same utility software - Winproladder.

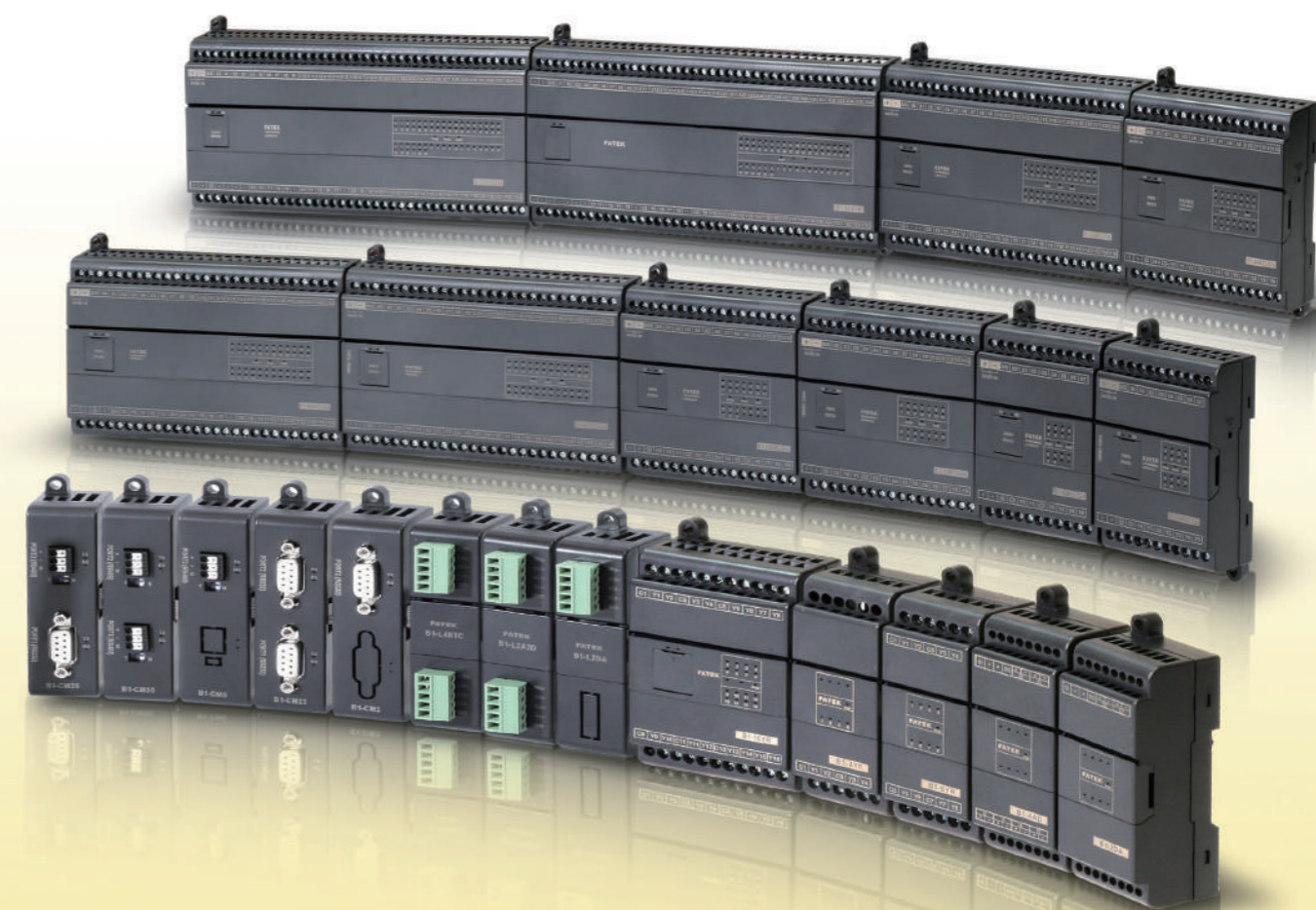

# System Configuration

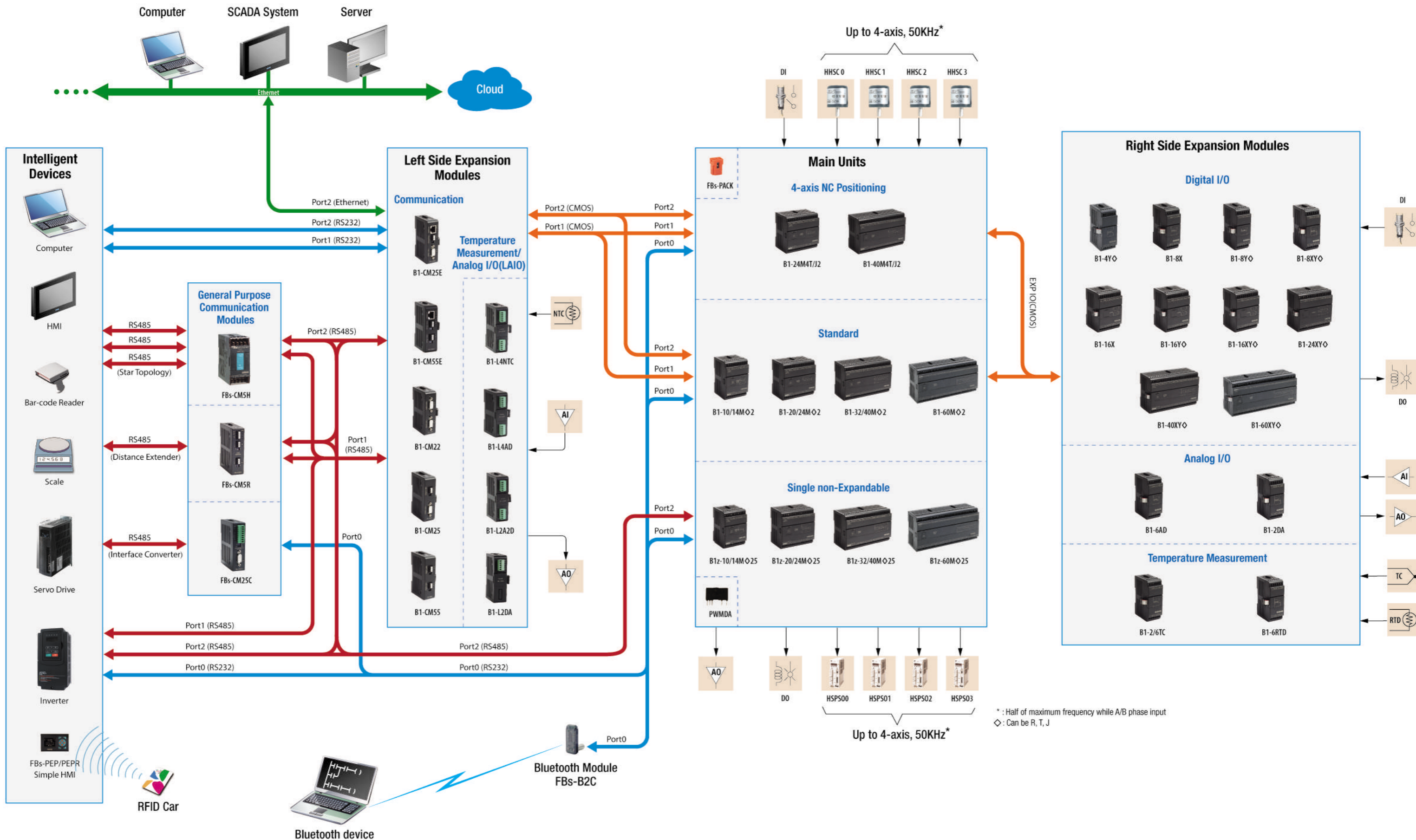

### Environmental Specifications

Item	Specification	Note
Storage temperature	-25°~70°C	
Operating ambient temperature	0°~55°C	
Relative humidity	5~95%	Non-condensing, RH-2
Pollution resistance	Degree II	
Corrosion resistance	Based on IEC-68 standard	
Altitude	≤2000m	
Vibration resistance	Fixed by DIN rail	0.5G, 2 hours for each direction of 3 axes
	Fasten by screw	2G, 2 hours for each direction of 3 axes
Shock resistance	10G, three times for each direction of 3 axes	
Noise resistance	1500Vp-p, pulse width 1μS	
Withstand voltage	500VAC, 1 minute (DC)	L, N to any terminal
	1500VAC, 1 minute (AC)	

### DC Model Power Specifications

Specification	Item	10/14 Points Main Unit	20/24 Points Main Unit	32/40 Points Main Unit	60 Points Main Unit
Input voltage		24VDC, -15%/+20%			
Max. power capability		2.5W/3W	3.5W/4W	4.5W/5W	6W
Inrush current		20A@24VDC			
Allowable power momentary interruption time		<2ms			
Fuse rating		2A, 125VDC			

### AC Model Power Specifications (custom products)

Specification	Item	10/14 Points Main Unit	20/24 Points Main Unit	32/40 Points Main Unit	60 Points Main Unit
Input power/Frequency		85 ~ 264VAC / 50 ~ 60Hz			
Max. power capability (Built-in sensor power supply)		21W			
Inrush current		20A@264VAC			
Allowable power momentary interruption time		<20mS			
Fuse rating		2A, 250VAC			

### Main Unit Specifications

\*1: Default, changeable by user  
\*2: LAIO and L4MTC module will occupy Port1

Specification	Item	B1	B1z	Note	
Execution speed		0.33uS / Sequential instruction			
Memory capacity	Program (Word)	7936 Words	3840 Words		
	Comment (Byte)	8K Bytes	4K Bytes		
Program memory		FLASH ROM or SRAM+Lithium battery Back-up			
Sequential instruction		36 instructions			
Function instruction		326 instructions(126 kinds)	323 instructions(123 kinds)	Include derivative instructions	
Flow chart command (SFC)		4 instructions			
Communication Interface	Port0 (RS232) Speed 4.8k~115.2kbps	Built-in		Default setting of each port is 906 kbps, Port1~2 provides FATEK or Modbus RTU/ASCII or user defined communication protocol	
	Port1~2 (RS232, RS485, Ethernet) Speed 4.8k~921.6kbps	Expandable Port1 and Port2	Built-in Port2(RS485) No expandable		
	Maximum link stations	254			
Digital (Bit status)	X	X+Y=128	6 / 8 / 12 / 14 / 20 / 24 / 36	Corresponding to external digital input	
	Y		4 / 6 / 8 / 10 / 12 / 16 / 24	Corresponds to external digital output	
	TR		TR0~TR39 (40)		
	M	Internal relay	Non-retentive	M0~M799 (800)*1	Can be configured as retentive type
			Retentive	M1400~M1911 (512)	
	Special relay		M800~M1399 (600)*1	Can be configured as non-retentive	
			M1912~M2001 (90)		

(Continue)

Specification	Item	B1	B1z	Note		
Digital (Bit status)	S	Step relay	Non-retentive	S0~S499 (500)*1	S20~S499 can be configured as retentive type	
			Retentive	S500~S999 (500)*1	Can be configured as non-retentive type	
	T	Timer "Time-Up" status contact	T0~T255 (256)			
	C	Counter "Count-Up" status contact	C0~C255 (256)			
Register (Word data)	TMR	Time current value register	0.01S Time base	T0~T49 (50)*1	T0~T255 members for each time base can be adjusted	
			0.1S Time base	T50~T199 (150)*1		
			1S Time base	T200~T255 (56)*1		
	CTR	Counter current value register	16-bit	Retentive	C0~C139 (140)*1	Can be configured as non-retentive type
				Non-retentive	C140~C199 (60)*1	Can be configured as retentive type
			32-bit	Retentive	C200~C239 (40)*1	Can be configured as non-retentive type
				Non-retentive	C240~C255 (16)*1	Can be configured as retentive type
	HR DR	Data register	Retentive	R0~R2999 (3000)*1	Can be configured as non-retentive type	
				D0~D3999 (4000)		
				R5000~R8071 (3072)*1		When not configured as ROR, it can serve normal register (for read/write)
	ROR	Read only register	R3000~R3839 (840)*1	Can be configured as retentive type	ROR is stored in special ROR area and not occupy program space	
	FR	File register	F0~F8191 (8192)		Saved/retrieved via dedicated instruction	
IR	Input register	R3840~R3857 (18)	-	Corresponding to the external numerical input		
OR	Output register	R3904~R3921 (18)	-	Corresponding to the external numerical output		
SR	Special system register	R3968~R4167 (200)		D4072~4075(4)corresponds LAIO Module inputs*2 D4076~4077(4)corresponds LAIO Module outputs*2		
		D4000~D4095 (96)				
	0.1mS High-speed timer register	R4152~R4154 (3)				
	High-speed counter register	Hardware(4 sets)	DR4096~DR4110 (4x4)			
		Software(4sets)	DR4112~DR4126 (4x4)			
Calendar register	R4128 (sec)	R4129 (min)	R4130 (hour)	R4131 (day)	-	
	R4132 (month)	R4133 (year)	R4134 (week)			
XR	Index register	V * Z (2), P0~P9 (10)				
Interrupt control	External interrupt control	32 interrupts(16 points input positive/negative edge)		Only main unit input points		
	Internal interrupt control	8 interrupts (1 * 2 * 3 * 4 * 5 * 10 * 50 * 100mS)				
	0.1mS high-speed timer	1(16-bit), 4(32-bit, share with HHSC)				
High-speed counter HSC	Hardware high-speed counter (HHSC)/32-bit	No. of channel	Up to 4			
		Counting mode	8 modes (U/D / U/Dx2 / P/R / P/Rx2 / A/B / A/Bx2 / A/Bx3 / A/Bx4)			
	Software high-speed counter(SHSC)/32-bit	No. of channel	Up to 4			
		Counting mode	3 modes (U/D / P/R / A/B)			
Counting frequency	Maximum sum up to 5KHz		Total number of HHSC and SHSC is 8 HHSC can be converted into 32-bit/0.1mS time base High-Speed Timer(HST) Half of maximum frequency while A/B phase input			
NC position pulse output (HSPSO)	Number of axis	Up to 4		Half of the maximum while A/B phase output		
	Output frequency	Maximum is 50KHz (Singed-end input)				
	Pulse output mode	3 modes (U/D / P/R / A/B)				
HSPWM output	Programming method	Dedicated position language		Maximum 4 axes linear interpolation		
	Interpolation	Maximum 4 axes linear interpolation				
Captured input	Number of points	Up to 4		72Hz~18.432KHz (with 0.1%resolution) 720Hz~184.3KHz(with 1%resolution)		
		Output frequency	72Hz~18.432KHz (with 0.1%resolution) 720Hz~184.3KHz(with 1%resolution)			
Digital filter	Points	Maximum 36 points (All inputs in main unit come with this feature)		Adjustable frequency 14KHz~1.8MHz Adjustable time constant 0.1~1.5mS/1~15mS(unit: 0.1mS/1mS) Time constant 1~15mS adjustable(unit: 1mS)		
		Minimum captured pulse width	>10μS (for Ultra high/high speed input)			
			>47μS (for medium speed input) >470μS (for medium/low speed input)			
X0~X15	X16~X35	Adjustable frequency 14KHz~1.8MHz		Chosen by frequency at high frequency		
		Adjustable time constant 0.1~1.5mS/1~15mS(unit: 0.1mS/1mS)		Chosen by time constant at low frequency		

### Digital Input (DI) Specification

\* : Half of maximum frequency while A/B phase input

Specification	Item	Main Unit			Extension module	Note
		High speed(HHSC)	Medium speed (SHSC)	Low speed (≥ X16)		
Maximum input frequency		50KHz*	Total 5KHz	-	-	HHSC: Hardware High speed counter SHSC: Software High speed counter
Input signal voltage		24VDC±10%				
Threshold current	ON	> 4mA		> 2.3mA		
	OFF	< 1.5mA		< 0.9mA		
Maximum input current		7.6mA		4.5mA		
Input status indication		Displayed by LED: light when "ON", dark when "OFF"				
Isolation method		Optical isolation, 500VAC, 1 minute				
SINK/SOURCE selection		Select by wiring methods (internal common terminal S/S and external common wiring)				
Noise filtering methods		AHF(0.42us)+DHF(14KHz~1.8MHz or 0.1~15ms)		AHF(0.2ms)+DHF(1~15ms)		DHF: Digital Hardware Filter AHF: Analog Hardware Filter
				AHF(1mS)		

### Wiring of 24VDC single-end SINK input

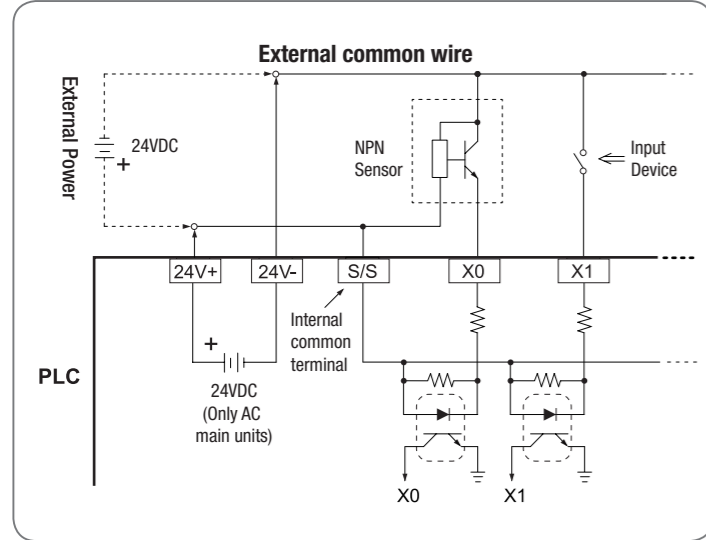

### Wiring of 24VDC single-end SOURCE input

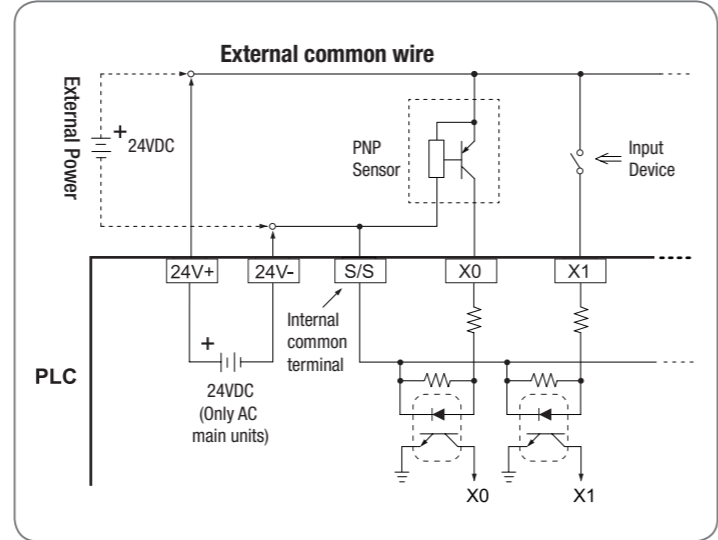

### Digital Output (DO) Specifications

\* : Half of maximum frequency while A/B phase output

Specification	Item	High speed transistor output (Main unit HSPSO)	Low speed transistor output	Single-end relay output	Note
Maximum output frequency		50KHz*	-	-	HSPSO : Hardware High Speed Pulse Output
Working voltage		5~30VDC		<250VAC/30VDC	
Maximum load current	Resistive	0.3A/0.1A (M4T/J)	0.5A	2A/single, 4A/common	
	Inductive			80VA(AC)/24VA(DC)	
Maximum voltage drop/conducting resistance (initial)		0.5V	1V	30mΩ (@1A, 6VDC)	
Minimum load		-	-	2mA/DC power	
Leakage current		< 0.1mA/30VDC		-	
Maximum output delay time	ON → OFF	15μS		10mS	
	OFF → ON	30μS			
Output status indication		Displayed by LED: light when "ON", dark when "OFF"			
Isolation method		Optical isolation, 500VAC, 1 minute		Electromagnetic isolation 1500VAC, 1 minute	

### Wiring of relay single-end output

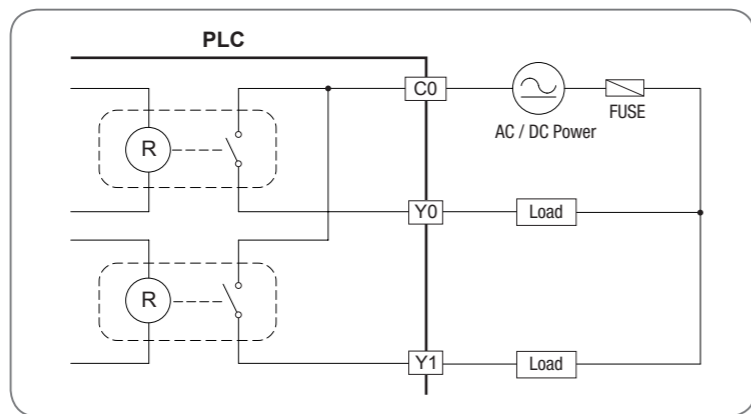

### Wiring of transistor single-end SINK output

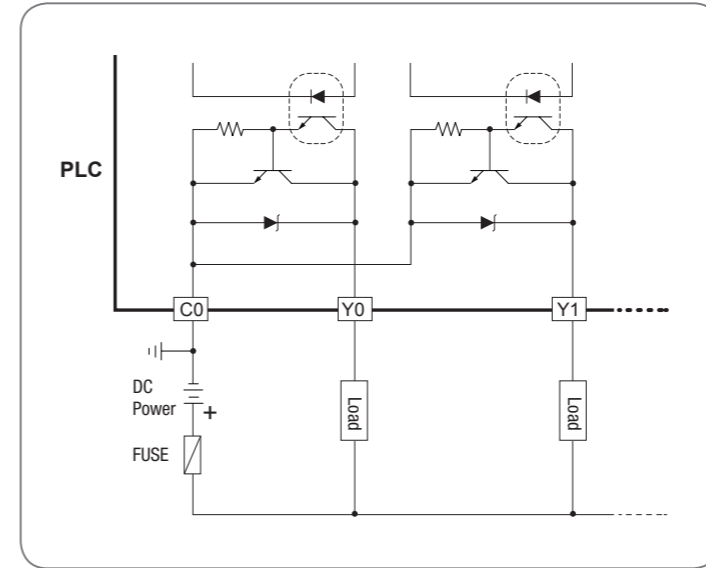

### Wiring of transistor single-end SOURCE output

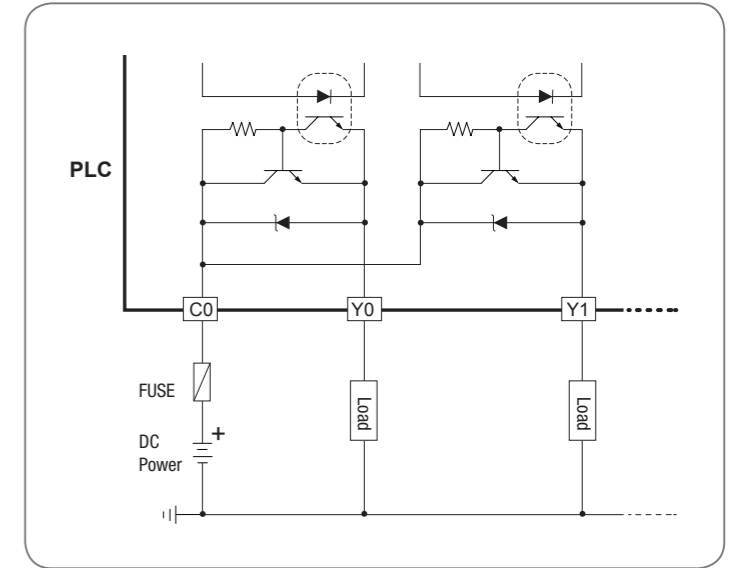

### Wiring of M4T main unit Y0~Y7 transistor single-end SINK output

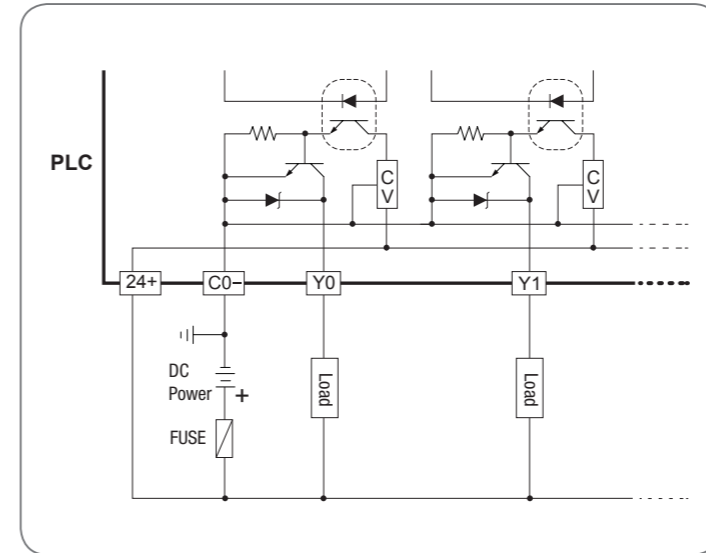

### Wiring of M4J main unit Y0~Y7 transistor single-end SOURCE output

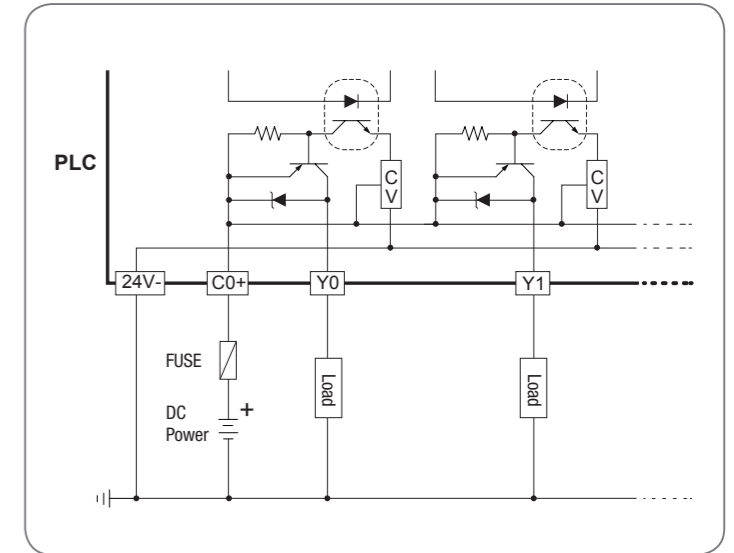

### Model Specification



### B1z Main Units

Spec.	Model	B1z-10MR	B1z-10M(T/J)	B1z-14MR	B1z-14M(T/J)	B1z-20MR	B1z-20M(T/J)	B1z-24MR	B1z-24M(T/J)	
Digital input	24VDC	High speed (50KHz)	4 points (2-axis single phase or A/B phase)		6 points (3-axis single phase or A/B phase)		8 points (4-axis single phase or A/B phase)			
		Medium (Total 5KHz)	2 points		4 points		6 points			
		Low speed	-		-		-			
Digital Output	Relay	High speed (50KHz)	4 points	-	6 points	-	8 points	-	10 points	
		Low speed	-	2 points (1-axis single phase or A/B phase)	-	2 points (1-axis single phase or A/B phase)	-	4 points (2-axis single phase or A/B phase)	-	4 points (2-axis single phase or A/B phase)
		Low speed	-	2 points	-	4 points	-	4 points	-	6 points
Communication port	Built-in	2 ports (Port0:RS232, Port2:RS485)								
	Expandable	-								
Calendar		-								
Wiring mechanism		5mm European fixed terminal block								
Dimension		Figure 1 (Standard), Figure 2 (Slim)				Figure 3 (Standard), Figure 4 (Slim)				



(Continue)

Spec.		Model	B1z-32MR	B1z-32M(T/J)	B1z-40MR	B1z-40M(T/J)	B1z-60MR	B1z-60M(T/J)
Digital input	24VDC	High speed (50KHz)	8 points (4-axis single phase or A/B phase)					
		Medium speed (Total 5KHz)	8 points					
		Low speed	4 points		8 points		20 points	
Digital Output	Relay	High speed (50KHz)	12	—	16	—	24	—
		Medium speed (Total 5KHz)	8 points					
		Low speed	4 points		8 points		20 points	
Digital Output	Transistor (5~30 VDC)	High speed (50KHz)	—	6 points (3-axis single phase or A/B phase)	—	6 points (3-axis single phase or A/B phase)	—	8 points (4-axis single phase or A/B phase)
		Low speed	—	6 points	—	10 points	—	16 points
Communication port	Built-in	2 ports (Port0:RS232, Port2:RS485)						
	Expandable	—						
Calendar		—						
Wiring mechanism		5mm European fixed terminal block						
Dimension		Figure 5 (Standard), Figure 6 (Slim)			Figure 7 (Standard), Figure 8 (Slim)			



### B1 Main Units

Spec.		Model	B1-10MR	B1-10M(T/J)	B1-14MR	B1-14M(T/J)	B1-20MR	B1-20M(T/J)	B1-24MR	B1-24M(T/J)
Digital input	24VDC	High speed (50KHz)	4 points (2-axis single phase or A/B phase)				6 points (3-axis single phase or A/B phase)		8 points (4-axis single phase or A/B phase)	
		Medium (Total 5KHz)	2 points		4 points		6 points		6 points	
		Low speed	—		—		—		—	
Digital Output	Relay	High speed (50KHz)	4 points	—	6 points	—	8 points	—	10 points	—
		Medium speed (Total 5KHz)	4 points				6 points		6 points	
		Low speed	—		—		—		—	
Digital Output	Transistor (5~30 VDC)	High speed (50KHz)	—	2 points (1-axis single phase or A/B phase)	—	2 points (1-axis single phase or A/B phase)	—	4 points (2-axis single phase or A/B phase)	—	4 points (2-axis single phase or A/B phase)
		Low speed	—	2 points	—	4 points	—	4 points	—	6 points
Communication port	Built-in	1 port (Port0:RS232)								
	Expandable	2 ports (Port1~2,RS485 or RS232 or Ethernet)								
Calendar		Built-in								
Wiring mechanism		5mm European fixed terminal block								
Dimension		Figure 1 (Standard), Figure 2 (Slim)				Figure 3 (Standard), Figure 4 (Slim)				



(Continue)

Spec.		Model	B1-32MR	B1-32M(T/J)	B1-40MR	B1-40M(T/J)	B1-60MR	B1-60M(T/J)
Digital input	24VDC	High speed (50KHz)	8 points (4-axis single phase or A/B phase)					
		Medium (Total 5KHz)	8 points					
		Low speed	4 points		8 points		20 points	
Digital Output	Relay	High speed (50KHz)	12	—	16	—	24	—
		Medium speed (Total 5KHz)	8 points					
		Low speed	4 points		8 points		20 points	
Digital Output	Transistor (5~30 VDC)	High speed (50KHz)	—	6 points (3-axis single phase or A/B phase)	—	6 points (3-axis single phase or A/B phase)	—	8 points (4-axis single phase or A/B phase)
		Low speed	—	6 points	—	10 points	—	16 points
Communication port	Built-in	1port (Port0:RS232)						
	Expandable	2 ports (Port1~2,RS485 or RS232 or Ethernet)						
Calendar		Built-in						
Wiring mechanism		5mm European fixed terminal block						
Dimension		Figure 5 (Standard), Figure 6 (Slim)			Figure 7 (Standard), Figure 8 (Slim)			

### B1 4-axis NC Positioning Main Units



### Left Side Communication Expansion Modules



Spec.		Model	B1-24M4T/J*	B1-40M4T/J*	Spec.	Model	B1-CM25E	B1-CM55E	
Digital input	24VDC	High speed (50KHz)	8 points (4-axis single phase or A/B phase)		Network interface	10 Base T			
		Medium (Total 5KHz)	6 points	8 points		Network protocol	TCP, UDP, ICMP, ARP		
		Low speed	—	8 points			Application protocol	FATEK client and server mode, Modbus-TCP server mode	
Digital Output	Transistor (5~30 VDC)	High speed (50KHz)	8 points (4-axis single phase or A/B phase)		PLC interface	Port 2			
		Low speed	2 points	8 points		PLC communication speed	9.6K / 19.2K / 38.4K / 57.6K / 115.2 K / 230.4 K		
Communication port	Built-in	1 port (Port0:RS232)		Expansion communication interface	RS232 (Port1)		RS485 (Port2)		
		2 ports (Port1~2,RS485 or RS232 or Ethernet)			RS485 (Port1, Port2)				
Calendar		Built-in		Application IP port number	FATEK port number 500, Modbus-TCP 502 or customized				
Wiring mechanism		5mm European fixed terminal block			Security protection	IP based access control			
Dimension		Figure 3 (Standard), Figure 4 (Slim)	Figure 5 (Standard), Figure 6 (Slim)	Indicators		Internet RX, TX, LINK LEDs indicators			
Dimension		Figure 11 (Standard only)							

\*J : Customized product



(Continue)

Spec.		Model	B1-CM2	B1-CM22	B1-CM5	B1-CM55	B1-CM25
Communication interface			RS232(2)	RS232(1,2)	RS485(2)	RS485(1,2)	RS232(1)+RS485(2)
Communication status			Receive (RX) : Green LED, Transmit (TX) : Red LED				
Wiring mechanism			DB9F	DB9F	3-pin spring terminal block		DB9F + 3-pin spring terminal block
Dimension			Figure 11( Standard), Figure 12 (Slim)				

### Left Side Temperature/Analog I/O Expansion Modules



Spec.		Model	B1-L4AD	B1-L2DA	B1-L2A2D	B1-L4NTC
Number of channels			4 channel input	2 channel output	2 channel input + 2 channel output	4 channel temperature input
Resolution			12 bits			
Input / Output signal range			0~10V(voltage) * 0~20mA(current)			100Ω ~ 100KΩ
Maximum resolution			2.44mV(voltage) * 4.88μA(current)			—
Accuracy			±1%			
Conversion time			Conversion once for each scan			
Maximum input signal			±15V(voltage) * 30mA(current)			—
Input impedance / Output load			Input impedance 100KΩ (voltage),125Ω (current) / Output load : 2K~1MΩ (voltage),0~500Ω (current)			—
Isolation method			Non-isolation			
Wiring mechanism			3.81mm European fixed terminal block			
Dimension			Figure 13( Standard), Figure 14 (Slim)			Figure 13( Standard)

### Right Side Digital I/O Expansion Modules



Spec.		Model	B1-4YR	B1-4Y(T/J)	B1-8X	B1-8YR	B1-8Y(T/J)	B1-8XYR	B1-8XY(T/J)
Digital input	24VDC	Low speed	—	—	8	—	—	4	4
		Relay	2A	4	—	8	—	4	—
Digital output	Transistor	0.5A	—	4	—	—	8	—	4
		Wiring mechanism	5mm European fixed terminal block						
Dimension		Figure 9 (Standard), Figure 10 (slim)							



(Continue)

Spec.		Model	B1-16X	B1-16YR	B1-16Y(T/J)	B1-16XYR	B1-16XY(T/J)	B1-24XYR	B1-24XY(T/J)
Digital input	24VDC	Low speed	16	—	—	8	8	14	14
		Relay	2A	—	16	—	8	—	10
Digital output	Transistor	0.5A	—	—	16	—	8	—	10
		Wiring mechanism	5mm European fixed terminal block						
Dimension		Figure 1 (Standard), Figure 2 (slim)						Figure 3 (Standard), Figure 4 (slim)	

# Dimensions

(Continue)

Spec.	Model	B1-40XYR	B1-40XY(T/J)	B1-60XYR	B1-60XY(T/J)
Digital input	24VDC Low speed	24	24	36	36
Digital output	Relay	16	—	24	—
	Transistor	0.5A	—	16	24
Wiring mechanism		5mm European fixed terminal block			
Dimension		Figure 5 (Standard), Figure 6 (slim)		Figure 7 (Standard), Figure 8 (slim)	

## Right side Analog I/O Expansion Modules

Spec.	Model	B1-6AD	B1-2DA
Input point		6 points input	2 points output
Input/Output value		12 bit	
Maximum resolution		1.22mV(Voltage), 2.44μA(Current)	
Input/Output signal range	Voltage	-10 ~ +10V, -5 ~ +5V, 0 ~ 10V, 0 ~ -5V	
	Current	-20 ~ +20mA, -10 ~ +10mA, 0 ~ 20mA, 0 ~ -10mA	
Accuracy		±1%	
Input impedance		63.2KΩ(Voltage) 250Ω(Current)	—
Conversion time		Conversion once for each scan	
Maximum input signal		±12V(Voltage) ±24mA(Current)	—
Allowable load range		—	500 ~ 1MΩ(Voltage) 0 ~ 500Ω(Current)
Isolation method		Non-isolation	
Wiring mechanism		3.81mm European fixed terminal block	
Dimension		Figure 9 (Standard), Figure 10 (slim)	

## Right side Temperature Measurement Expansion Modules

Spec.	Model	B1-2TC/6TC	B1-6RTD
Number of input points		2/6 points	6 points
Sensor type and temperature measurement range		J (-200~1200°C) E (-190~1000°C) K (-190~1300°C) T (-190~380°C) R (0~1800°C) B (350~1800°C) S (0~1700°C) N (-200~1000°C)	3-wire RTD sensor (JIS or DIN) Pt100(-200~850°C) Pt1000(-200~600°C)
	Temperature compensation	Built-in cold junction compensation	—
	Resolution	0.1°C	
	Temperature refresh time	Conversion once for each scan	
	Overall Precision	± (1%+1°C)	± 1%
Isolation method	Transform (power) and optical (signal) isolation, 500VAC, 1 minute, no isolation between each channel		
Power consumption	24VDC -15%/+20%, 2W max.		
Wiring mechanism	3.81 mm European fixed terminal block		
Dimension		Figure 9 (Standard)	

## FBs Compatible Peripheral (Refer to FBs-PLC Catalog for Detail Specifications)

Memory Pack	PWMDA Module	RFID card	Simple HMI	General Purpose Communication Converter		
FBs-PACK	PWMDA	CARD-H	FBs-PEP/PEPR	FBs-CM25C	FBs-CM5R	FBs-CM5H

Bluetooth Communication Module	USB Converter Cable	Port 0 Communication Cables			
FBs-B2C	FBs-U2C-MD-180	FBs-232P0-9F-150	FBs-232P0-9M-400	FBs-232P0-MD-200	FBs-232P0-MDR-200

## DC24V Power Supply

1A	2A	3A	4A	5A	6A
ADP-24V-1A	ADP-24V-2A	ADP-24V-3A	ADP-24V-4A	ADP-24V-5A	ADP-24V-6A

Figure 1 10/14 points main units or expansion modules (standard)

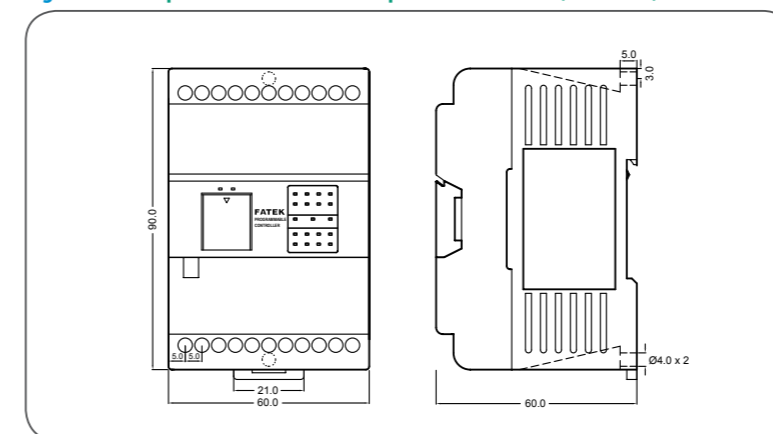

Figure 2 10/14 points units or expansion modules (slim)

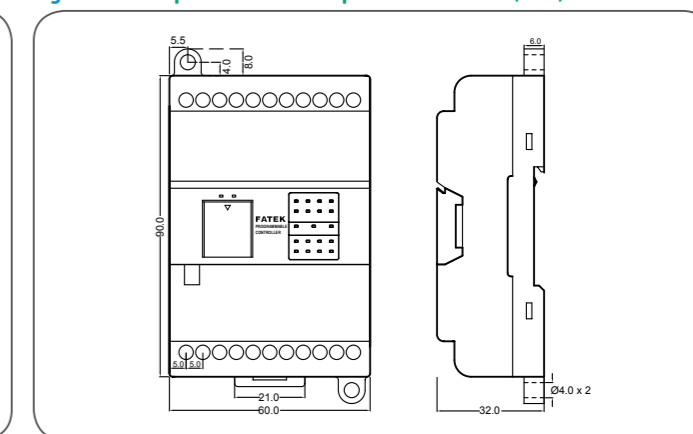

Figure 3 20/24 points main units or expansion modules (standard)

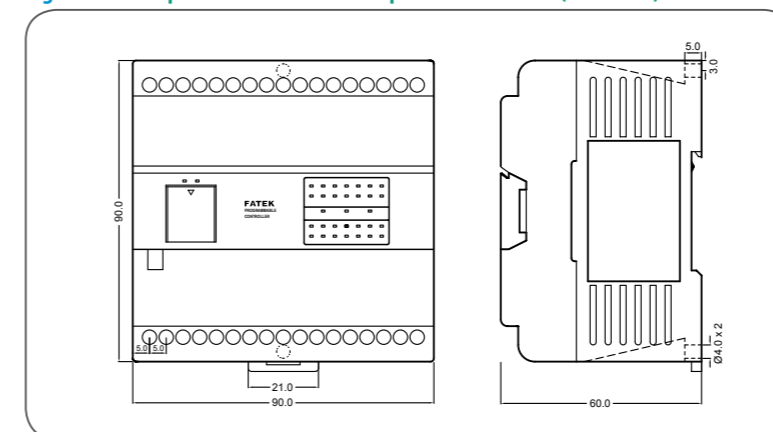

Figure 4 20/24 points main units or expansion modules (slim)

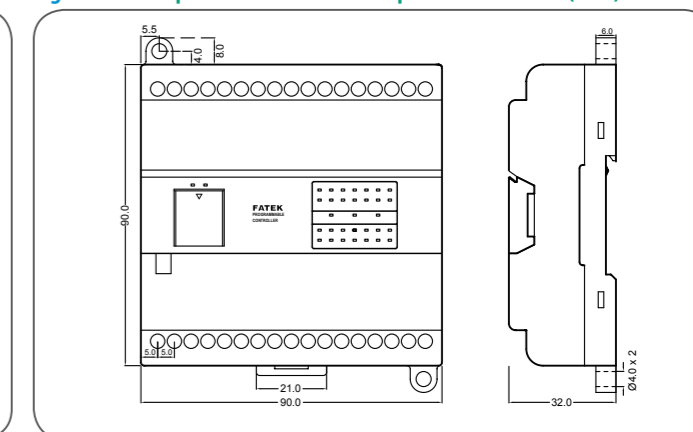

Figure 5 32/40 points main units or expansion modules (standard)

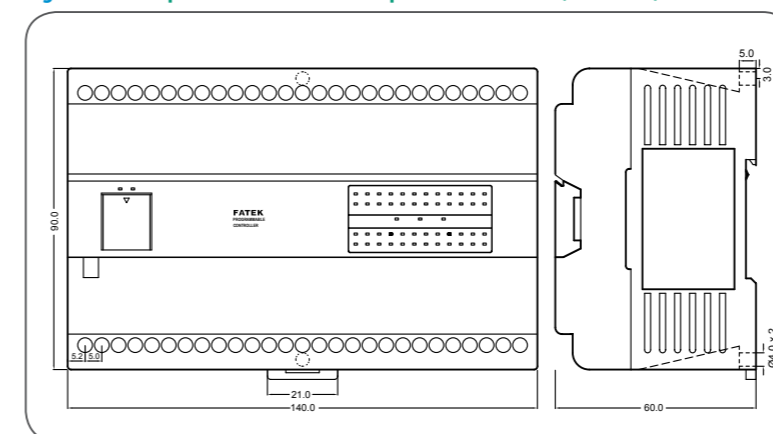

Figure 6 32/40 points main units of expansion modules (slim)

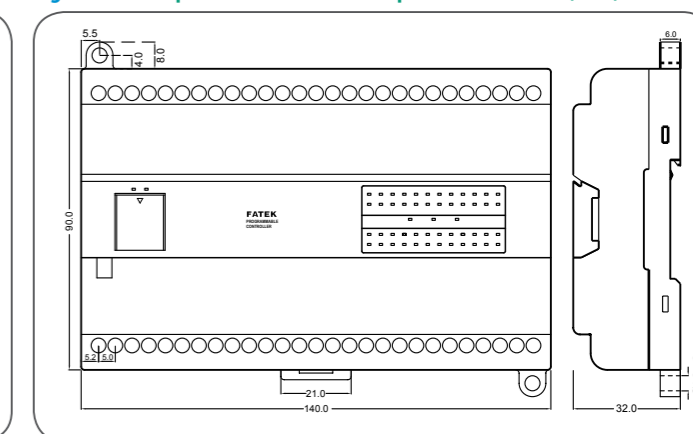
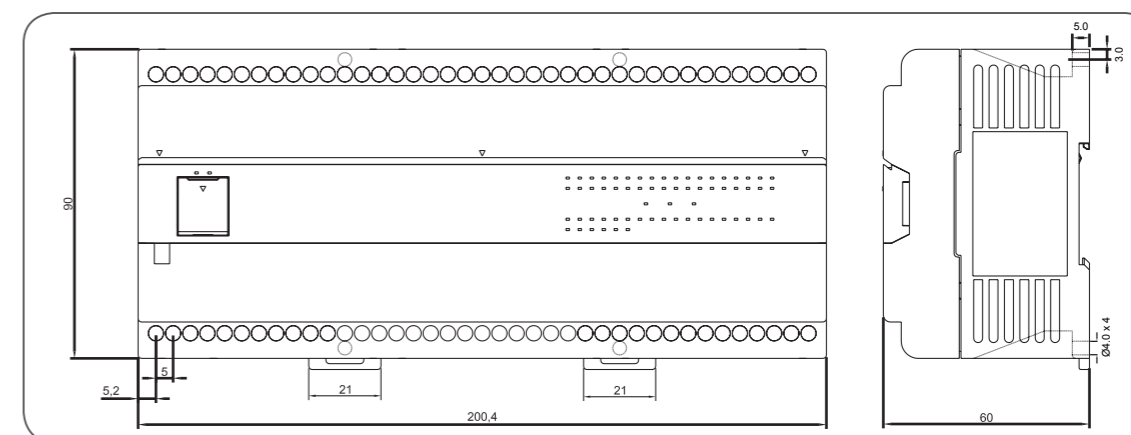

Figure 7 60 points main unit or expansion modules (standard)



# Model List

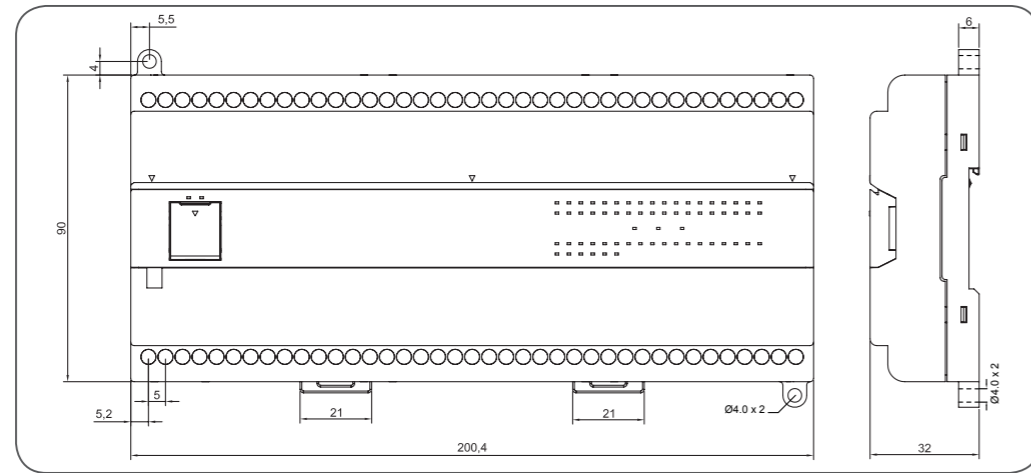

Figure 8 60 points main unit or expansion modules (Slim)

Figure 9 Right-side expansion (Standard)

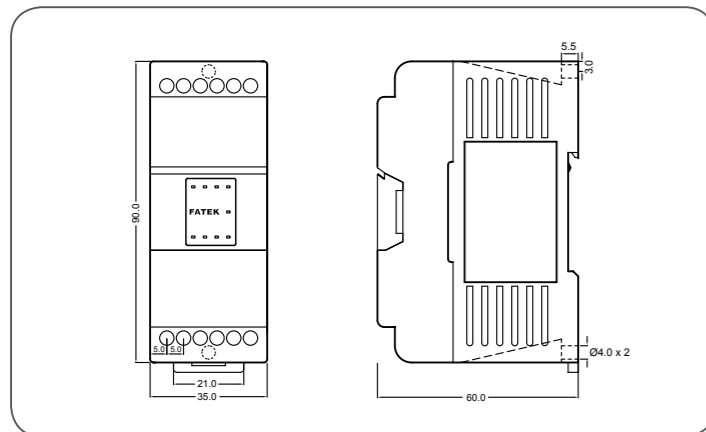

Figure 10 Right-side expansion (Slim)

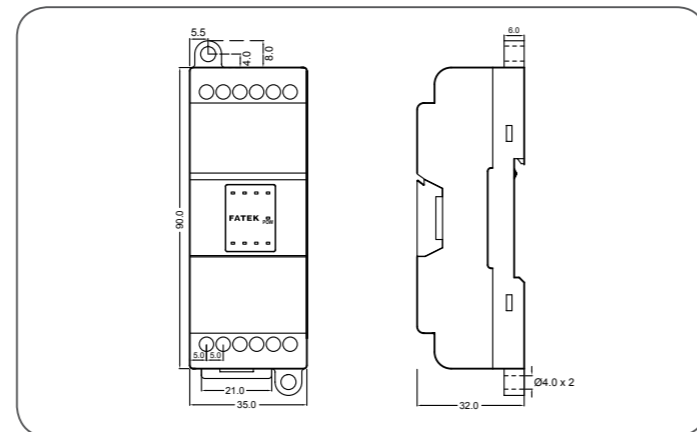

Figure 11 Left-side expansion (Standard)

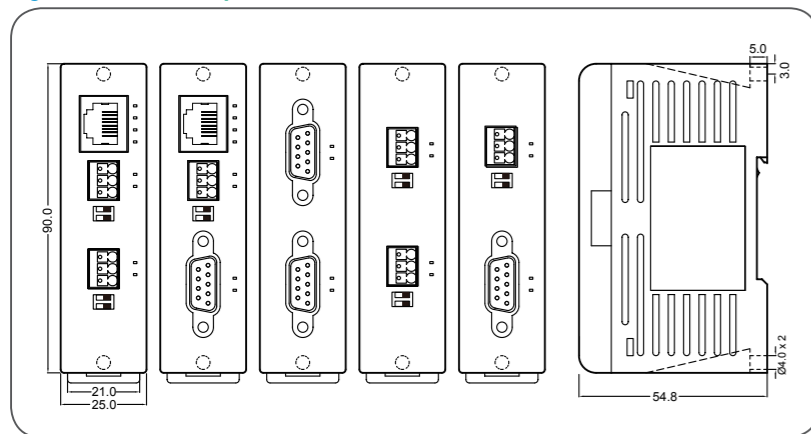

Figure 12 Left-side expansion (Slim)

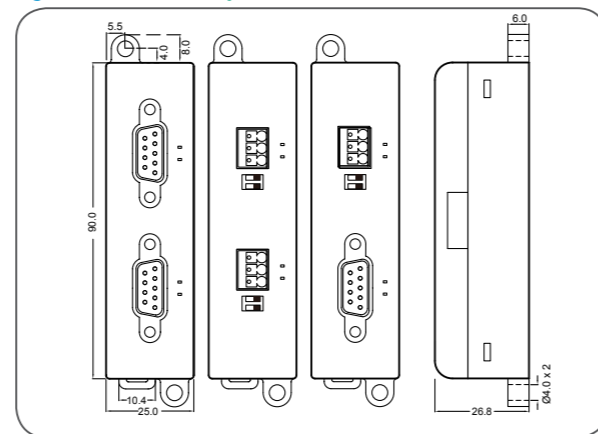

Figure 13 Left-side expansion (Standard)

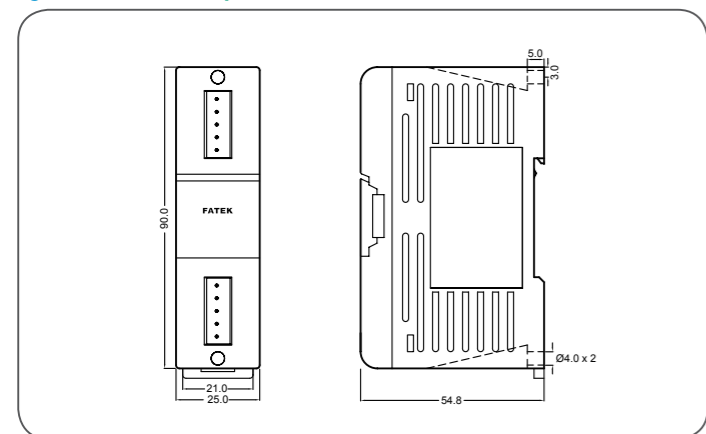
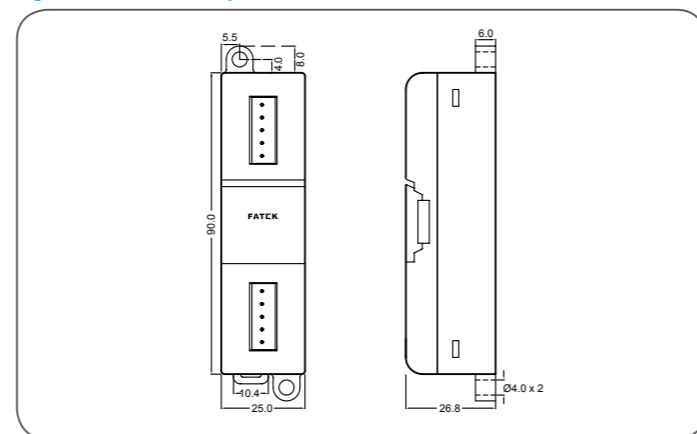

Figure 14 Left-side expansion (Slim)



Item Name	Module	Specifications		
Main Units	B1z Main Units	B1z-10M ◇ 25- ☆	6 points 24VDC digital input (4 points 50 KHz, 2 points total 5KHz), 4 points relay output or transistor output (2 points 50KHz), RS232(Port 0)+RS485(Port 2) communication ports, both sides are not expandable	
		B1z-14M ◇ 25- ☆	8 points 24VDC digital input (4 points 50 KHz, 4 points total 5KHz), 6 points relay output or transistor output (2 points 50KHz), RS232(Port 0)+RS485(Port 2) communication ports, both sides are not expandable	
		B1z-20M ◇ 25- ☆	12 points 24VDC digital input (6 points 50 KHz, 6 points total 5KHz), 8 points relay output or transistor output (4 points 50KHz), RS232(Port 0)+RS485(Port 2) communication ports, both sides are not expandable	
		B1z-24M ◇ 25- ☆	14 points 24VDC digital input (8 points 50 KHz, 6 points total 5KHz), 10 points relay output or transistor output (4 points 50KHz), RS232(Port 0)+RS485(Port 2) communication ports, both sides are not expandable	
		B1z-32M ◇ 25- ☆	20 points 24VDC digital input (8 points 50 KHz, 8 points total 5KHz), 12 points relay output or transistor output (6 points 50KHz), RS232(Port 0)+RS485(Port 2) communication ports, both sides are not expandable	
		B1z-40M ◇ 25- ☆	24 points 24VDC digital input (8 points 50 KHz, 8 points total 5KHz), 16 points relay output or transistor output (6 points 50KHz), RS232(Port 0)+RS485(Port 2) communication ports, both sides are not expandable	
	B1 Main Units	B1-10M ◇ 2- ☆	6 points 24VDC digital input (4 points 50 KHz, 2 points total 5KHz), 4 points relay output or transistor output (2 points 50KHz), RS232(Port 0) communication port	
		B1-14M ◇ 2- ☆	8 points 24VDC digital input (4 points 50 KHz, 4 points total 5KHz), 6 points relay output or transistor output (2 points 50KHz), RS232(Port 0) communication port	
		B1-20M ◇ 2- ☆	12 points 24VDC digital input (6 points 50 KHz, 6 points total 5KHz), 8 points relay output or transistor output (4 points 50KHz), RS232(Port 0) communication port	
		B1-24M ◇ 2- ☆	14 points 24VDC digital input (8 points 50 KHz, 6 points total 5KHz), 10 points relay output or transistor output (4 points 50KHz), RS232(Port 0) communication port	
		B1-32M ◇ 2- ☆	20 points 24VDC digital input (8 points 50 KHz, 8 points total 5KHz), 12 points relay output or transistor output (6 points 50KHz), RS232(Port 0) communication port	
		B1-40M ◇ 2- ☆	24 points 24VDC digital input (8 points 50 KHz, 8 points total 5KHz), 16 points relay output or transistor output (6 points 50KHz), RS232(Port 0) communication port	
4-axis NC positioning Modules	B1-24M4(T/J)2-D24 ☆	14 points 24VDC digital input (8 points 50 KHz, 6 points total 5KHz), 10 points transistor output (8 points 50KHz, 0.1A), RS232(Port 0) communication port, J is custom product		
	B1-40M4(T/J)2-D24 ☆	24 points 24VDC digital input (8 points 50 KHz, 8 points total 5KHz), 16 points transistor output (8 points 50KHz, 0.1A), RS232(Port 0) communication port, J is custom product		
Left Side Expansion Module	Communication Modules	B1-CM25E	1 port RS232 (Port 1) + 1 port RS485 (Port 2) + Ethernet network interface communication module	
		B1-CM55E	2 ports RS485 (Port 1, Port 2) + Ethernet network interface communication module	
		B1-CM2	1 port RS232 (Port 2) communication module	
		B1-CM22	2 port RS232 (Port1, Port2) communication module	
		B1-CM5	1 port RS485 (Port 2) communication module	
		B1-CM55	2 port RS485 (Port1, Port2) communication module	
		B1-CM25	1 port RS232 (Port 1) + 1 port RS485 (Port 2) communication module	
	LAIO Modules	B1-L2DA ☆	Non-isolated 2 channels, 12-bit analog output module (0~10V or 0~20mA)	
		B1-L4AD ☆	Non-isolated 4 channels, 12-bit analog input module (0~10V or 0~20mA)	
		B1-L2A2D ☆	Non-isolated 2channels, 12-bit analog input + 2 channels, 12-bit analog output combo analog module (0~10V or 0~20mA)	
Temperature Modules	B1-L4NTC ☆	4 channels, NTC temperature input module, 12-bit resolution, measuring range 100Ω~100KΩ		
Right Side Expansion Module	DIO Expansion Modules	B1-4Y ◇ ☆	4 points relay or transistor output	
		B1-8X ☆	8 points 24VDC digital input	
		B1-8Y ◇ ☆	8 points relay or transistor output	
		B1-8XY ◇ ☆	4 points 24VDC digital input, 4 points relay or transistor output	
		B1-16X ☆	16 points 24VDC digital input	
		B1-16Y ◇ ☆	16 points relay or transistor output	
		B1-16XY ◇ ☆	8 points 24VDC digital input, 8 points relay or transistor output	
		B1-24XY ◇ ☆	14 points 24VDC digital input, 10 points relay or transistor output	
		B1-40XY ◇ ☆	24 points 24VDC digital input, 16 points relay or transistor output	
		B1-60XY ◇ ☆	36 points 24VDC digital input, 24 points relay or transistor output	
	AIO Modules	B1-6AD ☆	Non-isolated 6 channels, 12-bit analog input module (Voltage:-10~10V,-5~5V,0~5V Current: -20~20mA,-10~10mA,0~20mA,0~10mA)	
		B1-2DA ☆	Non-isolated 2 channels, 12-bit analog output module (Voltage:-10~10V,-5~5V,0~5V Current: -20~20mA,-10~10mA,0~20mA,0~10mA)	
	Temperature Modules	B1-2/6TC	2/6 channels, thermocouple temperature input module with 0.1°C resolution, J, K, R, S, E, T, B, N thermocouple sensor	
		B1-6RTD	6 channels, RTD temperature input module with 0.1°C resolution, 3-wire RTD sensor (PT100 or PT1000)	
	FBs Compatible Peripheral	Memory Pack	FBs-PACK	PLC program memory pack with 20K Words program, 20K Words register
		PWMDA Module	PWMDA	10-bit single channel pulses width modulation (PWM) 0~10V analog output (AO) module
		RFID Card	CARD-H	General purpose RFID (ISO-14443A Standard) (for FBs-PEPR)
		Simple HMI	FBs-PEP/PEPR	Multi-characters with graphics-based Parameter Entry Panel, built-in RFID Read/Write module with PEPR
General Purpose Communication Converters		FBs-CM25C	General purpose RS232 to RS485/RS422 communication interface converter with optical isolation	
		FBs-CM5R	General purpose RS485 repeater with optical isolation	
		FBs-CM5H	General purpose 4 ports RS485 HUB with optical isolation, RS485 can be connected as star connection	
Bluetooth Communication Module		FBs-B2C	Bluetooth Module for PLC Main Unit Port 0	
USB Communication Converter		FBs-U2C-MD-180	Communication converter cable with standard USB AM connector to RS232 Mini-DIN 4M connector (used in standard PC USB to FBs main unit Port0 RS232), length 180cm	
Port 0 Communication Cables		FBs-232P0-9F-150	Mini-DIN 4M to DB9F communication cable (FBs main unit Port 0 RS232 connect to standard DB9M), length 150cm	
	FBs-232P0-9M-400	Mini-DIN 4M to DB9M communication cable (FBs main unit Port 0 RS232 connect to standard DB9F), length 400cm		
	FBs-232P0-MD-200	Mini-DIN 4M to Mini-DIN 4M communication cable (FBs main unit Port 0 RS232 connect to FBs-PEP/PEPR), length 200cm		
	FBs-232P0-MDR-200	Mini-DIN 4M to 90° Mini-DIN 4M communication cable (FBs main unit Port 0 RS232 connect to FBs-PEP/PEPR), length 200cm		
DC24V Power Supply	ADP-24V-1A	90~240VAC Input Voltage, 50/60Hz, Output Voltage: 24VDC, Output Current: 1A, DIN-RAIL Type		
	ADP-24V-2A	90~240VAC Input Voltage, 50/60Hz, Output Voltage: 24VDC, Output Current: 2A, DIN-RAIL Type		
	ADP-24V-3A	90~240VAC Input Voltage, 50/60Hz, Output Voltage: 24VDC, Output Current: 3A, DIN-RAIL Type		
	ADP-24V-4A	90~240VAC Input Voltage, 50/60Hz, Output Voltage: 24VDC, Output Current: 4A, DIN-RAIL Type		
	ADP-24V-5A	90~240VAC Input Voltage, 50/60Hz, Output Voltage: 24VDC, Output Current: 5A, DIN-RAIL Type		
	ADP-24V-6A	90~240VAC Input Voltage, 50/60Hz, Output Voltage: 24VDC, Output Current: 6A, DIN-RAIL Type		

◇ : R – Relay output, T – Transistor SINK (NPN) output, J – SOURCE (PNP) output  
 ◎ : D24 – 21.6~28.8 VDC power supply, AC – 85~264 VAC power supply (customized products)  
 ☆ : Blank – Standard case, -S – Slim case (units with AC power supply have no slim case)