

# USB-2416 Series

## 24-Bit Multifunction Temperature & Voltage Devices



The USB-2416 Series offers high-resolution voltage or thermocouple measurements along with digital I/O. Analog output functionality is available with the USB-2416-4AO.

### Features

- Measure thermocouples or voltage
- 32 analog inputs, expandable to 64
- 24-bit resolution
- 1 kS/s sampling
- 4 analog outputs (USB-2416-4AO only)
- 8 digital I/O, expandable to 24
- Two counters
- Regulated power supply included

### Supported Operating Systems

- Windows 10/8/7/Vista® 32/64-bit

### Overview

The USB-2416 Series offers exceptional performance and accuracy for voltage and temperature measurements.

Designed for the USB bus, each device provides up to 32 analog input channels with 24-bit resolution, 8 digital I/O and two counter inputs. The USB-2416-4AO also features four analog outputs.

Connect to the AI-EXP32 expansion device for an additional 32 channels of analog input and 16 digital I/O lines.

Analog inputs are user-configurable for voltage or thermocouple input on a per-channel basis.

### Analog Input

Each device provides 32 SE/16 DIFF analog inputs, expandable to 64 SE/32 DIFF. Software-selectable voltage input ranges are configurable per-channel.

USB-2416 Series devices can sample analog input channels at up to 1 kS/s. Open thermocouple detection is automatically enabled for thermocouple measurements.

### Analog Output (USB-2416-4AO Only)

The USB-2416-4AO provides four 16-bit analog outputs with a  $\pm 10$  V output range. The analog outputs can be updated at a maximum rate of 1 kS/s (system-dependent).

### Digital I/O

USB-2416 Series devices provide eight digital I/O lines with read/write rates of 500 port or single bit reads per second. Each DIO channel is an open-drain. Digital outputs can sink up to 150 mA for direct drive applications. The maximum sink current is 150 mA per eight-channel bank, or if all eight channels are used, 18 mA (maximum) per channel.

### Counter Input

Each device has two 32-bit event counters that accept frequency inputs up to 1 MHz. The internal counter increments when the TTL levels transition from low to high.

### Channel Expansion with the AI-EXP32

The AI-EXP32 expansion device provides an additional 32 SE/16 DIFF analog inputs and 16 DIO lines. The AI-EXP32 supports all analog/thermocouple input and digital I/O features of the USB-2416 Series devices to which it is connected.

The AI-EXP32 receives power from the connected USB-2416 Series device.

USB-2416 Series Selection Chart

Model	Analog Inputs	Throughput Rate	Analog Outputs	Digital I/O	Counters
USB-2416	32 SE/16 DIFF	Up to 1 kS/s	—	8	2
USB-2416-4AO	32 SE/16 DIFF	Up to 1 kS/s	4	8	2
USB-2416 with AI-EXP32	64 SE/32 DIFF	Up to 1 kS/s	—	24	2
USB-2416-4AO with AI-EXP32	64 SE/32 DIFF	Up to 1 kS/s	4	24	2

# USB-2416 Series

## General Information

### Calibration

The USB-2416 Series is factory-calibrated using a NIST-traceable calibration process. Specifications are guaranteed for one year.

The USB-2416 Series also supports field calibration for users to calibrate the device locally with the InstaCal utility.

### Power

The USB-2416 Series receives power from the PS-5V2AEPS external supply that ships with the device.

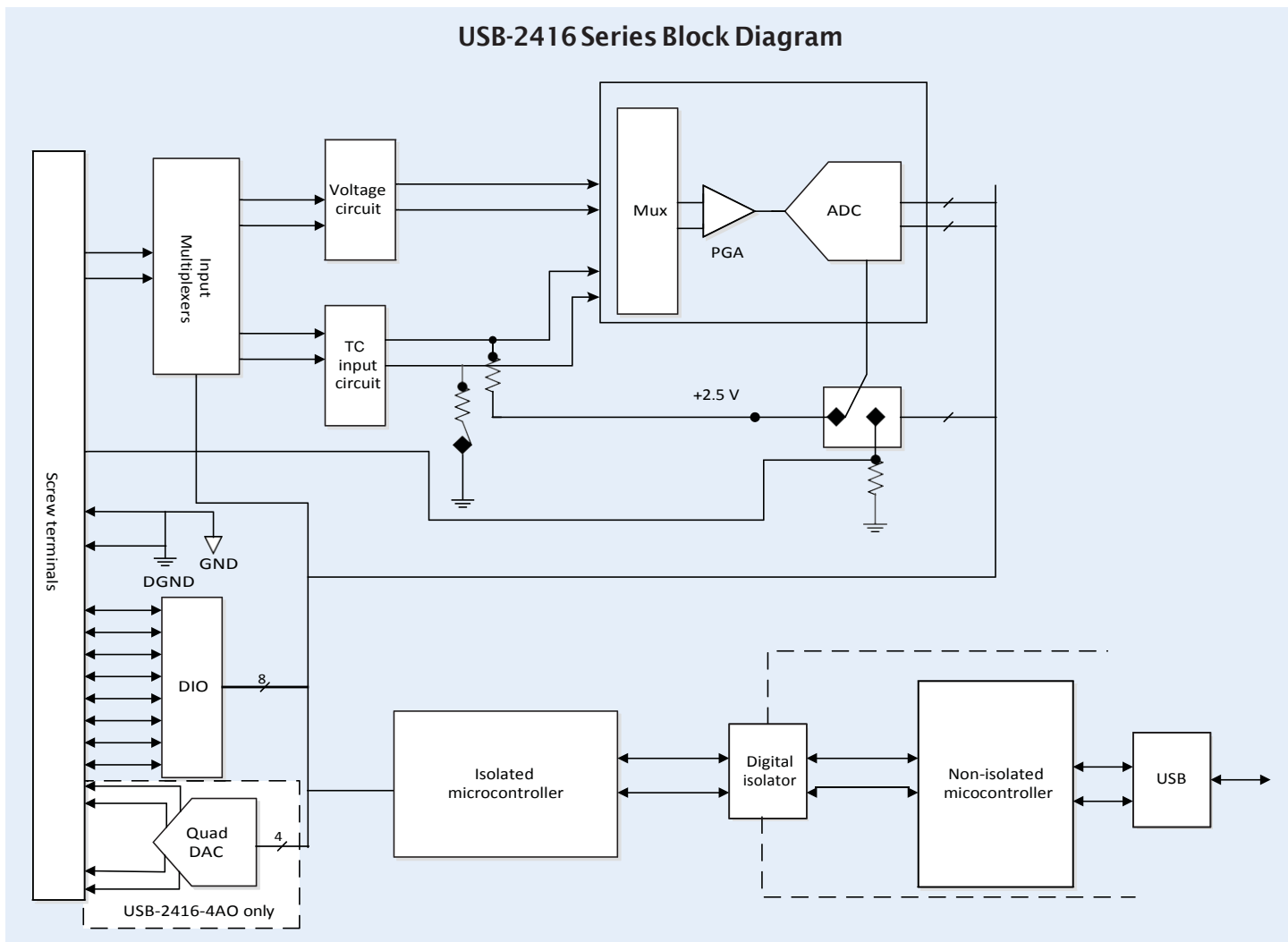

### Software Support

USB-2416 Series devices are supported by the software in the table below.

#### Ready-to-Run Applications

##### [DAQami™](#)



Data acquisition companion software with drag-and-drop interface that is used to acquire, view, and log data, and generate signals. DAQami can be configured to log analog, digital, and counter channels, and to view that data in real-time or post-acquisition on user-configurable displays. Logged data can be exported for use in Excel® or MATLAB®. Windows OS

DAQami is included with the free MCC DAQ Software bundle (CD/download). Install DAQami and try the fully-functional software for 30 days. After 30 days, all features except for data logging and data export will continue to be available – data logging and data export features can be unlocked by purchasing the software.

##### [InstaCal™](#)



An interactive installation, configuration, and test utility for MCC hardware. Windows OS

InstaCal is included with the free MCC DAQ Software bundle (CD/download).

##### [TracerDAQ™ and TracerDAQ Pro](#)



Virtual strip chart, oscilloscope, function generator, and rate generator applications used to generate, acquire, analyze, display, and export data. Supported features may vary by hardware. The Pro version provides enhanced features. Windows OS

TracerDAQ is included with the free MCC DAQ Software bundle (CD/download).

TracerDAQ Pro is available as a purchased software download.

#### General-Purpose Programming Support

##### [Universal Library™ \(UL\)](#)



Library for developing applications in C, C++, VB, C# .Net, VB .Net, and Python. Windows OS

The UL is included with the free MCC DAQ Software bundle (CD/download).

##### [Linux® driver](#)



Open-source Linux drivers are available for most MCC devices. Example programs are also provided.

#### Application-Specific Programming Support

##### [ULx for NI LabVIEW™](#)

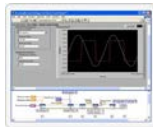

A comprehensive library of VIs and example programs for NI LabVIEW that is used to develop custom applications that interact with most MCC devices. Windows OS

ULx for NI LabVIEW is included with the free MCC DAQ Software bundle (CD/download).

##### [DASYLab®](#)



Icon-based data acquisition, graphics, control, and analysis software that allows users to create complex applications in minimal time without text-based programming. Windows OS

DASYLab is available as a purchased software download. An evaluation version is available for 28 days.

# USB-2416 Series



## Specifications

### Specifications

All specifications are subject to change without notice.  
Typical for 25 °C unless otherwise specified.  
All specifications apply to all temperature and voltage input channels unless otherwise specified.

#### Analog Input

**A/D converter type:** ADS1256, 24-bit Sigma Delta  
**A/D data rates:** 3750 samples per second (S/s), 2000 S/s, 1000 S/s, 500 S/s, 100 S/s, 60 S/s, 50 S/s, 25 S/s, 10 S/s, 5 S/s, 2.5 S/s

#### Throughput

**Single channel:** 2.5 Hz to 1102.94 Hz, software-selectable  
**Multiple channels:** 0.16 Hz to 1102.94 Hz, software-selectable  
**Number of channels:** Up to 32 channels individually software configurable as single-ended or differential; thermocouples require differential mode  
**Input isolation:** 500 VDC min between field wiring and USB interface  
**Channel configurations:** Temperature sensor input, software programmable to match sensor type; voltage input

#### Input voltage range

**Thermocouple mode:**  $\pm 0.078125$  V  
**Voltage mode:**  $\pm 20$  V,  $\pm 10$  V,  $\pm 5$  V,  $\pm 2.5$  V,  $\pm 1.25$  V,  $\pm 0.625$  V,  $\pm 0.3125$  V,  $\pm 0.15625$  V,  $\pm 0.078125$  V, software configurable  
**Absolute maximum input voltage:** CxH-CxL relative to GND,  $\pm 30$  V max (power on),  $\pm 10$  V max (power off)

**Input impedance:** 2 G $\Omega$  (power on), 390  $\Omega$  (power off)

**Input leakage current:**  $\pm 10.6$  nA

**Input capacitance:** 590 pF

**Maximum working voltage (signal+common mode):**

**Voltage mode ( $\pm 20$  V):**  $\pm 20.01$  V max  
**Voltage mode (all other voltage ranges):**  $\pm 10.25$  V max

#### Common mode rejection ratio

**Thermocouple mode ( $f_{in} = 60$  Hz):** 110 dB  
**Voltage mode ( $f_{in} = 60$  Hz, all input ranges):** 90 dB

**ADC resolution:** 24 bits

**Crosstalk:** Adjacent channels, 100 dB

**Input Coupling:** DC

**Channel gain queue:** Up to 64 elements, software configurable channel and range

**Warm-up time:** 45 minutes min

**Open thermocouple detect:** Enabled when configured for a thermocouple sensor

**CJC sensor accuracy:** 15 °C to 35 °C,  $\pm 0.15$  °C typ; 0 °C to 55 °C,  $\pm 0.5$  °C max

Channel Configurations		
Channel	Category	Configuration
CxH/CxL	Thermocouple	16 differential
CxH/CxL	Voltage	Up to 32, individually configurable as either single ended or differential

Compatible Sensors		
Thermocouple Sensor Types		
J: -210 °C to 1200 °C	T: -270 °C to 400 °C	
K: -270 °C to 1372 °C	N: -270 °C to 1300 °C	
R: -50 °C to 1768 °C	E: -270 °C to 1000 °C	
S: -50 °C to 1768 °C	B: 0 °C to 1820 °C	

#### Accuracy

Refer to the [USB-2416 User's Guide](#) or [USB-2416-4AO User's Guide](#) for thermocouple and voltage measurement accuracy tables.

#### Throughput Rate

The maximum throughput is 1.1 kS/s aggregate. Users can set conversion rates on a per-channel basis. Refer to the hardware user's guide for single- and multi-channel throughput rates.

#### Analog Voltage Output (USB-2416-4AO only)

Unused VDACx output channels should be left disconnected. The output voltage defaults to 0 V whenever the host PC is reset, shut down or suspended. The duration of the output transient depends on the enumeration process of the host PC. Typically, the output of the USB-2416-4AO is stable after two seconds.

**Digital to analog converter:** DAC8555

**Number of channels:** 4, 16-bit

#### Output ranges

**Calibrated:**  $\pm 10$  V

**Uncalibrated:**  $\pm 10.05$  V, software configurable

**Output transient:** Host PC is reset, powered on, suspended or a reset command is issued to device

**Duration:** 2 s

**Amplitude:** 2 V p-p

#### Initial power on

**Duration:** 50 ms

**Amplitude:** 5 V peak

**Differential non-linearity:**  $\pm 25$  LSB, typ,  $\pm 1$  LSB max

**Output current:** VDACx pins,  $\pm 3.5$  mA max

**Output short-circuit protection:** VDACx connected to AGND, unlimited duration

**Output coupling:** DC

**VDACx readback:** Each output independently measured by the A/D converter,

**Power on and reset state:** DACs cleared to zero-scale, 0 V,  $\pm 50$  mV

**Output noise:** 30  $\mu$ Vrms

**Settling time:** To rated accuracy, 10 V step, 45  $\mu$ s

**Slew rate:** 1.0 V/ $\mu$ s

#### Throughput

**Single-channel:** 1000 S/s max, system-dependent

**Multi-channel:** 1000 S/s /#ch max, system-dependent

#### Calibrated absolute accuracy

**Range:**  $\pm 10$  V

**Accuracy ( $\pm$ LSB):** 16.0

#### Calibrated absolute accuracy components

**Range:**  $\pm 10$  v

**% of reading:**  $\pm 0.0183$

**Offset ( $\pm$ mV):** 1.831

**Temp drift (%/°C):** 0.00055

**Absolute accuracy at FS ( $\pm$ mV):** 3.661

#### Relative accuracy

**Range:**  $\pm 10$  V

**Relative accuracy ( $\pm$ LSB):** 4.0 typical

#### Digital Input

**Number of I/O:** 8 channels

**Configuration:** independently read from (DIN) or written to (DOUT)

**Input voltage range:** 0 V to 15 V

**Input type:** CMOS (Schmitt trigger)

**Input characteristics:** 47 k $\Omega$  pull-up/pull-down resistor, 28 k $\Omega$  series resistor

**Maximum input voltage range:** 0 V to 20 V max (power on/off, relative to DGND)  
**Pull-up/pull-down configuration:** All pins pulled up to +5 V via individual 47 k $\Omega$  resistors; pull-down is available with an onboard jumper.

**Transfer rate (software paced):** 500 port reads or single bit reads per second typical.

**Input high voltage:** 1.3 V min, 2.2 V max

**Input low voltage:** 1.5 V max, 0.6 V min

**Schmitt trigger hysteresis:** 0.4 V min, 1.2 V max

#### Digital Output

**Number of I/O:** 8 channels

**Configuration:** independently read from (DIN) or written to (DOUT)

**Output characteristics:** 47 k $\Omega$  pull-up, open drain (DMOS transistor)

**Pull-up configuration:** All pins pulled up to +5 V via individual 47 k $\Omega$  resistors.

**Transfer rate (software paced)**

**Digital output:** 500 port writes or single bit writes per second typical.

**Output voltage range:** 0 V to 5 V (no external pull up resistor, internal 47 k $\Omega$  pull-up resistors connected to 5 V by default); 0 V to 15 V max

**Drain to source breakdown voltage:** 50 V min

**Off state leakage current:** 0.1  $\mu$ A

**Sink current capability:** 150 mA max (continuous) per output pin, 150 mA max (continuous) for all eight channels

**DMOS transistor on-resistance (drain to source):** 4  $\Omega$

#### Counter Input

**Pin name:** CTR0, CTR1

**Number of channels:** 2 channels

**Resolution:** 32-bits

**Counter type:** Event counter

**Input type:** Schmitt trigger, rising edge triggered

**Counter read/writes rates:** System dependent, 500 reads per second

**Input characteristics:** Each CTRx input pin, 562 k $\Omega$  to +5 V, 10 k $\Omega$  series resistor

# USB-2416 Series



## Ordering

**Input voltage range:**  $\pm 15$  V max  
**Maximum input voltage range:** CTR0,CTR1 relative to GND and DGND,  $\pm 20$  V max (power on/off)  
**Input high voltage:** 1.3 V min, 2.2 V max  
**Input low voltage:** 1.5 V max, 0.6 V min  
**Schmitt trigger hysteresis:** 0.4 V min, 1.2 V max  
**Input bandwidth (-3 dB):** 1 MHz  
**Input capacitance:** 25 pF  
**Input leakage current:**  $\pm 120$  nA  
**Input frequency:** 1 MHz, max  
**High pulse width:** 500 ns, min  
**Low pulse width:** 500 ns, min

### Mechanical

**Dimensions (L x W x H):** 245 x 146 x 50 mm (9.65 x 5.75 x 1.97 in.)  
**User Connection Length:** 5 m max

### Environmental

**Operating Temperature range:** 0 °C to 50 °C max  
**Storage temperature range:** -40 to 85 °C max  
**Humidity:** 0 to 90% non-condensing max  
These specifications do not apply to the AC power adapter.

### Power

**Supply current:** Quiescent current, 340 mA  
**Voltage supervisor limits:** 4.5 V >  $V_{ext}$  or  $V_{ext}$  > 5.5 V PWR LED = Off, (power fault); 4.5 V <  $V_{ext}$  < 5.5 V, PWR LED = On  
**+5 V user output voltage range:** 4.9 V min to 5.1 V max  
**User +5V user output current:** Available at terminal block pin 35, 10 mA max  
**Isolation:** Measurement system to PC, 500 VDC min  
**AC power adapter:** MCC p/n PS-5V2AEPS; included with hardware  
**External power input:** +5 VDC, 2.4 A, 12 Watt, 5% regulation

## Ordering Information

### Hardware

Part No.	Description
USB-2416	24-bit, isolated, high-channel-count USB DAQ device. Includes USB cable, power adapter, and MCC DAQ software CD.
USB-2416-4AO	24-bit, isolated, high-channel-count, USB DAQ device with 4 analog outputs. Includes USB cable, power adapter, and MCC DAQ software CD.
AI-EXP32	Analog input expansion module for USB-2416 Series

### Accessories

Part No.	Description
ACC-202	DIN-rail kit.
ACC-216	Connector kit with 6 detachable screw terminals.
PS-5V2AEPS	Replacement power supply, 12-watt. Interchangeable plugs are available separately.
745690-E001	E-type thermocouples wire, fiberglass (0 °C to 482 °C, 32 °F to 900 °F), 1 m
745690-E002	E-type thermocouples wire, fiberglass (0 °C to 482 °C, 32 °F to 900 °F), 2 m
745690-J001	J-type thermocouples wire, fiberglass (0 °C to 482 °C, 32 °F to 900 °F), 1 m
745690-J002	J-type thermocouples wire, fiberglass (0 °C to 482 °C, 32 °F to 900 °F), 2 m
745690-K001	K-type thermocouples wire, fiberglass (0 °C to 482 °C, 32 °F to 900 °F), 1 m
745690-K002	K-type thermocouples wire, fiberglass (0 °C to 482 °C, 32 °F to 900 °F), 2 m
745690-T001	T-type thermocouples wire, fiberglass (0 °C to 482 °C, 32 °F to 900 °F), 1 m
745690-T002	T-type thermocouples wire, fiberglass (0 °C to 482 °C, 32 °F to 900 °F), 2 m

## Software also Available from MCC

Part No.	Description
DAQami	Data acquisition companion software for acquiring data and generating signals
TracerDAQ Pro	Out-of-the-box virtual instrument suite with strip chart, oscilloscope, function generator, and rate generator – professional version
DASYLab	Icon-based data acquisition, graphics, control, and analysis software