

PFN-2000 Series User Manual

Version 1.30, Sep 2014

Service and usage information for



PFN-2042



PFN-2051



PFN-2052



PFN-2053



PFN-2055



PFN-2060



PFN-2019

Warranty

All products manufactured by ICP DAS are under warranty regarding defective materials for a period of one year, beginning from the date of delivery to the original purchaser.

Warning

ICP DAS assumes no liability for any damage resulting from the use of this product. ICP DAS reserves the right to change this manual at any time without notice. The information furnished by ICP DAS is believed to be accurate and reliable. However, no responsibility is assumed by ICP DAS for its use, not for any infringements of patents or other rights of third parties resulting from its use.

Copyright

Copyright © 2014 by ICP DAS Co., Ltd. All rights are reserved.

Trademark

The names used for identification only may be registered trademarks of their respective companies.

Contact US

If you have any problem, please feel free to contact us.
You can count on us for quick response.

Email: service@icpdas.com

Table of Contents

Table of Contents	3
1. Introduction	6
1.1. Product Information	7
1.2. Features	8
1.3. Specification	9
1.3.1. System Specification	9
1.3.2. I/O Specification	11
1.3.2.1. PFN-2042.....	11
1.3.2.2. PFN-2051	12
1.3.2.3. PFN-2052.....	13
1.3.2.4. PFN-2053.....	14
1.3.2.5. PFN-2055.....	15
1.3.2.6. PFN-2060.....	17
1.3.2.7. PFN-2019.....	19
1.4. Internal I/O Structure	20
1.4.1. PFN-2042.....	20
1.4.2. PFN-2051	21
1.4.3. PFN-2052.....	21
1.4.4. PFN-2053.....	22
1.4.5. PFN-2055.....	22
1.4.6. PFN-2060.....	23
1.4.7. PFN-2019.....	24
1.5. Wiring Connection	25
1.5.1. PFN-2042.....	25
1.5.2. PFN-2051	25
1.5.3. PFN-2052.....	26

1.5.4. PFN-2053.....	26
1.5.5. PFN-2055.....	27
1.5.6. PFN-2060.....	27
1.5.7. PFN-2019.....	28
1.6. Overview	29
1.6.1. Front Panel.....	29
1.6.2. Top Panel	32
1.7. Dimensions.....	34
2. PROFINET	35
2.1. Device classes of PROFINET IO.....	35
2.2. Device Description.....	36
2.3. Conformance Classes (CC).....	37
3. Basic Application	38
3.1. Connect to Network, PC and PROFINET IO controller.....	38
3.2. Network configuration.....	39
3.3. GSD Import	46
3.4. Project Setup.....	48
3.5. I/O Data Exchange	56
3.6. Module Parameter Settings	58
4. MiniOS7 Utility Tool.....	60
4.1. Installing the MiniOS7 Utility.....	60
4.2. Using MiniOS7 Utility to get Ethernet settings and firmware version	61
5. PFN_Tool Utility.....	63
5.1. Installing the PFN_Tool Utility	63
5.2. PFN_Tool Utility Functionalities	64
5.2.1. Module Search	64

5.2.2. Module Basic Configuration.....	65
5.2.3. Module Advanced Configuration.....	67
6. Troubleshooting	69

1. Introduction

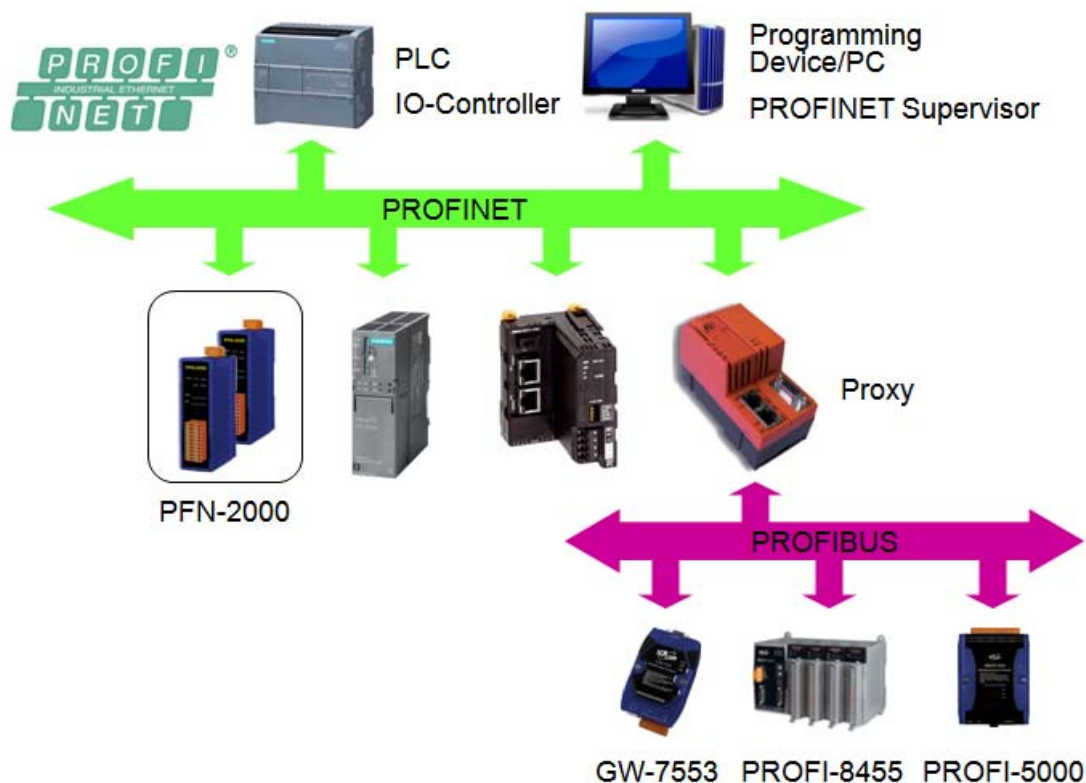

PROFINET is an open Industrial Ethernet standard developed by the PROFIBUS Organization (PI). Based on Ethernet versatility, PROFINET make vertical integration of field level with Enterprise level easily. PROFINET is automation in real time, so it can cover all requirements of the Automation Industry. PROFINET is fit for factory automation, process automation, safety applications and motion control applications, etc.

PROFINET contains 2 different solutions. They are PROFINET IO and PROFINET CBA (Component Based Automation). PFN-2000 series modules are PROFINET IO devices. The user can access and configure the modules easily by using the GSDML file in any PROFINET Engineering tool, and exchange process data quickly with the IO controller.

PFN-2000 User Manual (Version 1.30, Sep/2014)

1.1. Product Information

PFN-2000 provides a variety of digital/analog module choice, listed in the following table.

Type	Model	Description
DC Digital Output	PFN-2042	Isolated 16-ch DO PROFINET I/O Module
DC Digital Input	PFN-2051	Isolated 16-ch DI PROFINET I/O Module
	PFN-2052	Ch-to-ch Isolated 8-ch DI PROFINET I/O Module
	PFN-2053	16-ch Dry Contact DI PROFINET I/O Module
DC Digital Input and Output	PFN-2055	Isolated 8-ch DI and 8-ch DO PROFINET I/O Module
Power Relay Output	PFN-2060	Isolated 6-ch DI and 6-ch relay output PROFINET I/O Module
Analog Input	PFN-2019	10-channel Universal Analog Input PROFINET I/O Module

1.2. Features

- ◆ **Transfer protocol: PROFINET IO**
- ◆ **Supported Ethernet services: ICMP, IGMP, ARP, DHCP, TELNET, TFTP, SNMP, VLAN Priority Tagging**
- ◆ **Supported PROFINET services: RTC, RTA, CL-RPC, DCP, LLDP, I&M**
- ◆ **PROFINET Conformance Class B and RT Class 1**
- ◆ **Cyclic Time: 1ms (min)**
- ◆ **Generic GSDML File Provided**
- ◆ **Integrated 2-Port Switch**
- ◆ **Automatic MDI / MDI-X Crossover for Plug-and-play**
- ◆ **Provide LED indicators**
- ◆ **Robust, fan less design**
- ◆ **4 kV Contact ESD protection for any terminal**
- ◆ **Wide range of power input (+10 ~ +30 VDC) and operating temperature (-25 ~ +75°C)**

1.3. Specification

1.3.1. System Specification

Hardware	
CPU	32-bit CPU Core
RAM/Flash/EEPROM	32 MB / 4 MB / 8 KB
Watchdog	CPU built-in
ESD Protection	4 kV class A

PROFINET Interface	
Protocol	PROFINET IO Device
Conformance Classes	Class B
Services	RTC, RTA, CL-RPC, DCP, LLDP, I&M
Cycle Time	1 ms (min)

Ethernet Interface	
Controller	10/100Base-TX Ethernet Controller (Auto-negotiating, Auto_MDIX)
Connector	RJ-45 x 2 (LED indicators) , Integrated 2-Port Switch
Services	ICMP, IGMP, ARP, DHCP, TELNET, TFTP, SNMP, VLAN Priority Tagging

LED Display	
Round LED	PWR LED, S1A LED, S1B LED, S2A LED, S2B LED

Power Requirements	
Power supply	Unregulated +10 ~ +30 VDC
Protection	Power reverse polarity protection, Over-voltage brown-out protection
Power Consumption	Digital I/O module - 4.5W
	Analog I/O module - 5W

Mechanical	
Dimensions (W x L x H)	Digital I/O module - 33 mm x 107 mm x 126 mm
	Analog I/O module - 33 mm x 93 mm x 126 mm
Installation	DIN Rail or Wall mounting

Environment	
Operating Temperature	-25 °C ~ +75 °C
Storage Temperature	-30 °C ~ +80 °C
Humidity	10~ 90 % RH, non-condensing

1.3.2. I/O Specification

1.3.2.1. PFN-2042

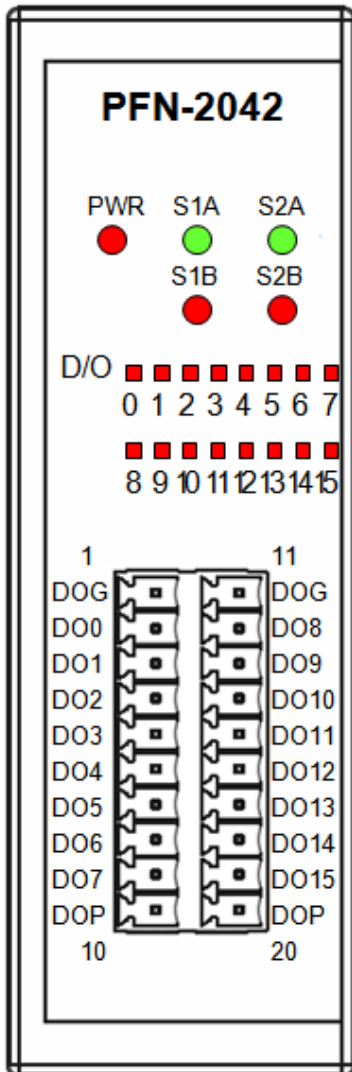

Terminal No.	Pin Assignment	Terminal No.	Pin Assignment
01	DO GND	11	DO GND
02	D00	12	D08
03	D01	13	D09
04	D02	14	D010
05	D03	15	D011
06	D04	16	D012
07	D05	17	D013
08	D06	18	D014
09	D07	19	D015
10	DO PWR	20	DO PWR

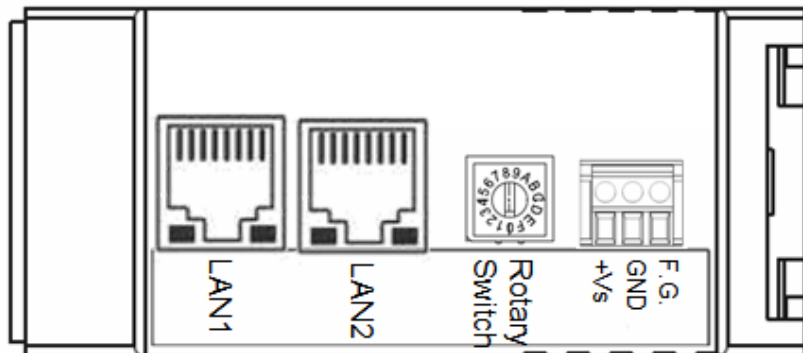

Digital Output	
Output Channels	16
Output Type	Sink, Open Collector
Load Voltage	+3.5 V _{DC} ~ +50 V _{DC}
Max. Load Current	700 mA/channel at 25 °C
Over-Voltage Protection	+60 V _{DC}
Intra-module Isolation	3750 Vrms

1.3.2.2. PFN-2051

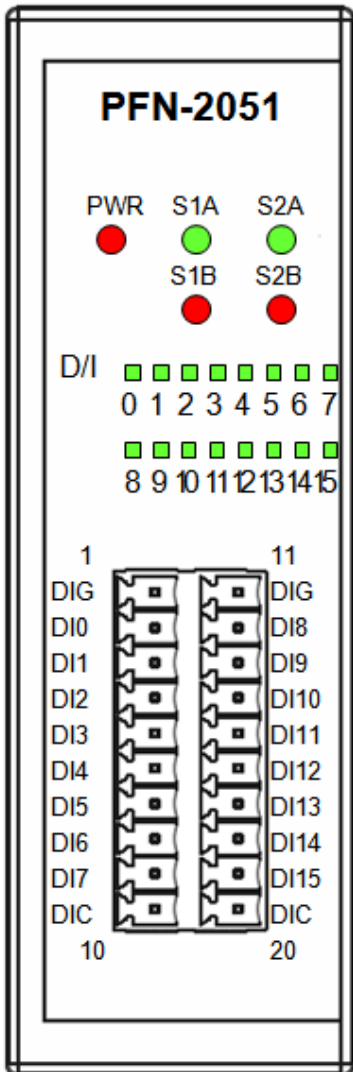

Terminal No.	Pin Assignment	Terminal No.	Pin Assignment
01	DI GND	11	DI GND
02	DI0	12	DI8
03	DI1	13	DI9
04	DI2	14	DI10
05	DI3	15	DI11
06	DI4	16	DI12
07	DI5	17	DI13
08	DI6	18	DI14
09	DI7	19	DI15
10	DI COM	20	DI COM

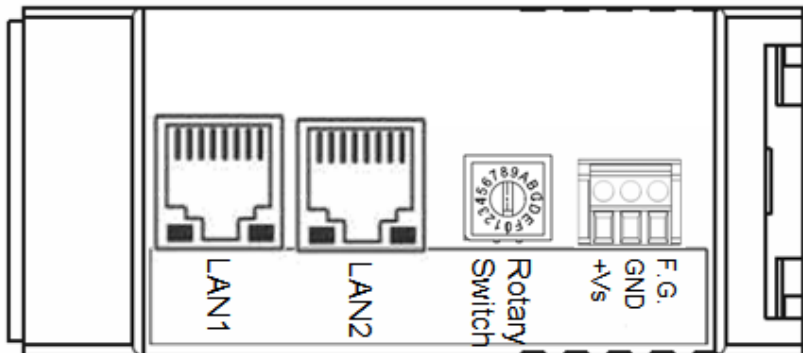

Digital Input	
Input Channels	16
Input Type	Dry Contact (Source), Wet Contact (Sink, Source)
On Voltage Level	Dry: Open Wet: +10 V _{DC} ~ +50 V _{DC}
Off Voltage Level	Dry: Close to DI.GND Wet: +4 V _{DC} max.
Input Impedance	10 kOhm, 0.5 W
Photo-Isolation	3750 Vrms

1.3.2.3. PFN-2052

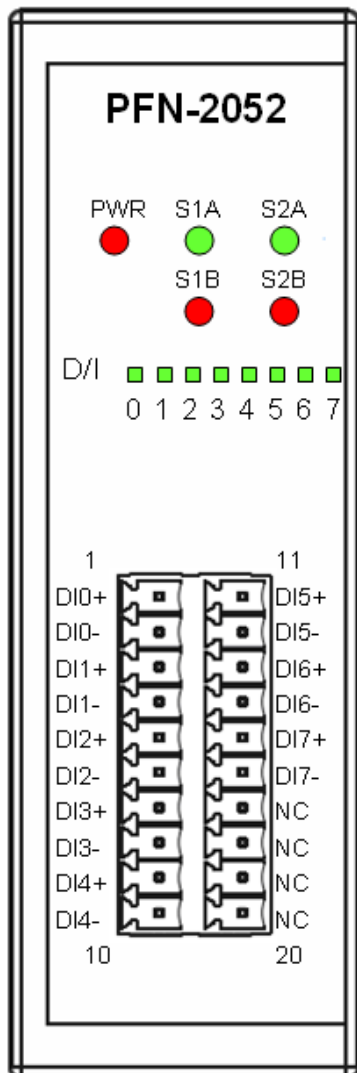

Terminal No.	Pin Assignment	Terminal No.	Pin Assignment
01	DI0+	11	DI5+
02	DI0-	12	DI5-
03	DI1+	13	DI6+
04	DI1-	14	DI6-
05	DI2+	15	DI7+
06	DI2-	16	DI7-
07	DI3+	17	NC
08	DI3-	18	NC
09	DI4+	19	NC
10	DI4-	20	NC

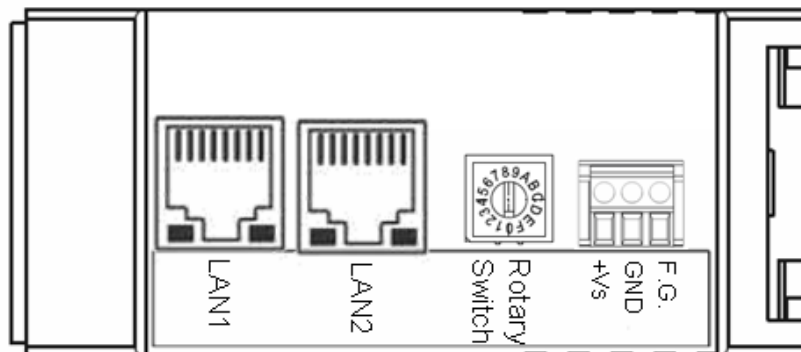

Digital Input	
Input Channels	8
Input Type	Wet Contact (Sink, Source)
On Voltage Level	+4 V _{DC} ~ 30 V _{DC}
Off Voltage Level	+1 V _{DC} max.
Input Impedance	3 kOhm, 0.3 W
Photo-Isolation	3750 Vrms

1.3.2.4. PFN-2053

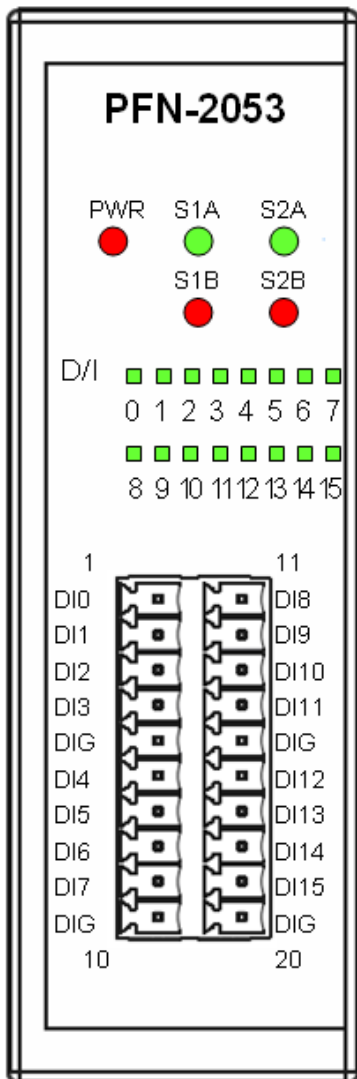

Terminal No.	Pin Assignment	Terminal No.	Pin Assignment
01	DI0	11	DI8
02	DI1	12	DI9
03	DI2	13	DI10
04	DI3	14	DI11
05	DI GND	15	DI GND
06	DI4	16	DI12
07	DI5	17	DI13
08	DI6	18	DI14
09	DI7	19	DI15
10	DI GND	20	DI GND

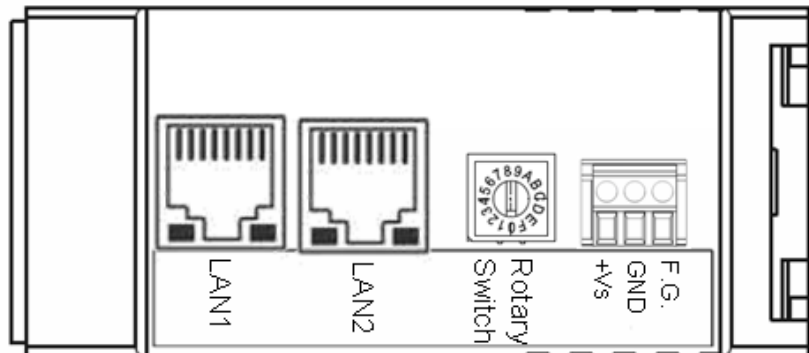

Digital Input	
Input Channels	16
Input Type	Dry Contact (Source)
On Voltage Level	Close to DI.GND
Off Voltage Level	Open
Input Impedance	3 kOhm, 0.3 W
Photo-Isolation	3750 Vrms

1.3.2.5. PFN-2055

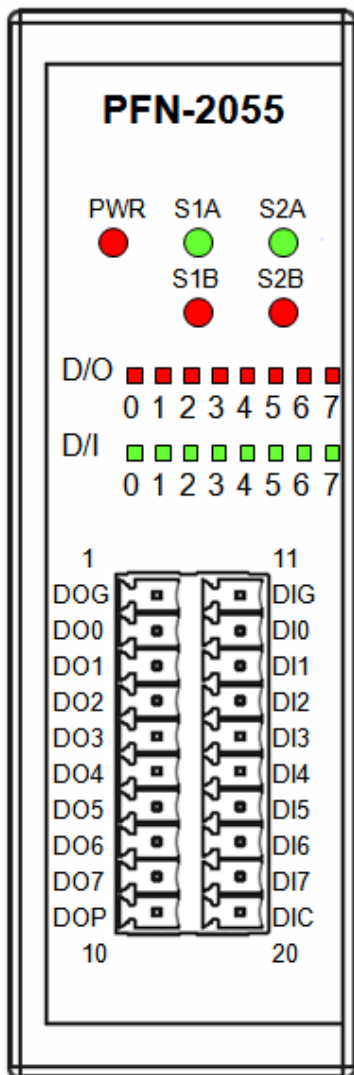

Terminal No.	Pin Assignment	Terminal No.	Pin Assignment
01	DO GND	11	DI GND
02	D00	12	DI0
03	D01	13	DI1
04	D02	14	DI2
05	D03	15	DI3
06	D04	16	DI4
07	D05	17	DI5
08	D06	18	DI6
09	D07	19	DI7
10	DO PWR	20	DI COM

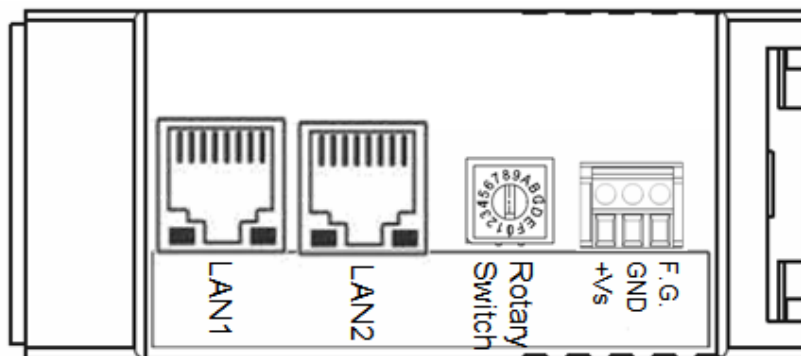

Digital Input	
Input Channels	8
Input Type	Dry Contact (Source), Wet Contact (Sink, Source)
On Voltage Level	Dry: Close to DI.GND Wet: +10 V _{DC} ~ +50 V _{DC}
Off Voltage Level	Dry: Open Wet: +4 V _{DC} max.
Input Impedance	10 kOhm, 0.5 W
Photo-Isolation	3750 Vrms

Digital Output	
Output Channels	8
Output Type	Sink, Open Collector
Output Voltage	+3.5 V _{DC} ~ +50 V _{DC}
Max. Load Current	700 mA/channel at 25 °C Direct drive power relay module
Over-Voltage Protection	+60 V _{DC}
Intra-module Isolation	3750 Vrms

1.3.2.6. PFN-2060

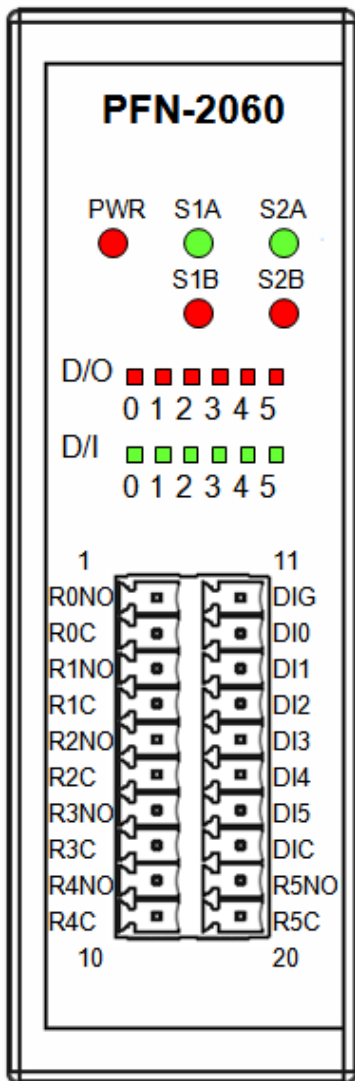

Terminal No.	Pin Assignment	Terminal No.	Pin Assignment
01	RL0 NO	11	DI GND
02	RL0 COM	12	DI0
03	RL1 NO	13	DI1
04	RL1 COM	14	DI2
05	RL2 NO	15	DI3
06	RL2 COM	16	DI4
07	RL3 NO	17	DI5
08	RL3 COM	18	DI COM
09	RL4 NO	19	RL5 NO
10	RL4 COM	20	RL5 COM

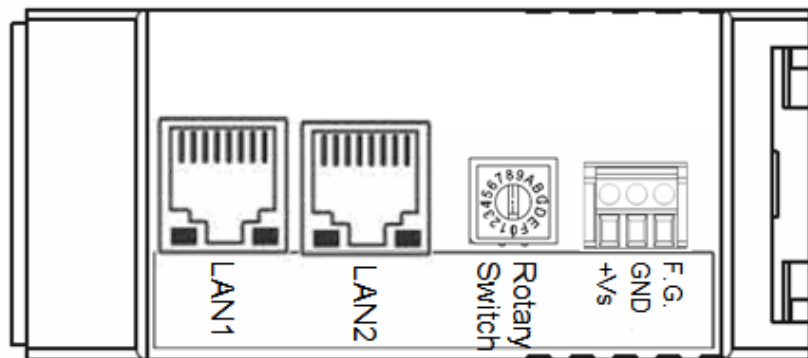

Digital Input	
Input Channels	6
Input Type	Dry Contact (Source), Wet Contact (Sink, Source)
On Voltage Level	Dry: Close to DI.GND Wet: +10 V _{DC} ~ +50 V _{DC}
Off Voltage Level	Dry: Open Wet: +4 V _{DC} max.
Input Impedance	10 kOhm, 0.5 W
Photo-Isolation	3750 Vrms

Digital Output	
Output Channels	6
Output Type	Power Relay, Form A x 6
Contact Rating	AC: 125 V@0.6A DC: 30V@2A, 110V@0.6A
Operating Time	3 ms
Release Time	2 ms
Total Switching Time	10 ms
Surge Strength	500 V _{AC} (50/60 Hz)
Insulation resistance	1000 MW min. at 500 V _{DC}

1.3.2.7. PFN-2019

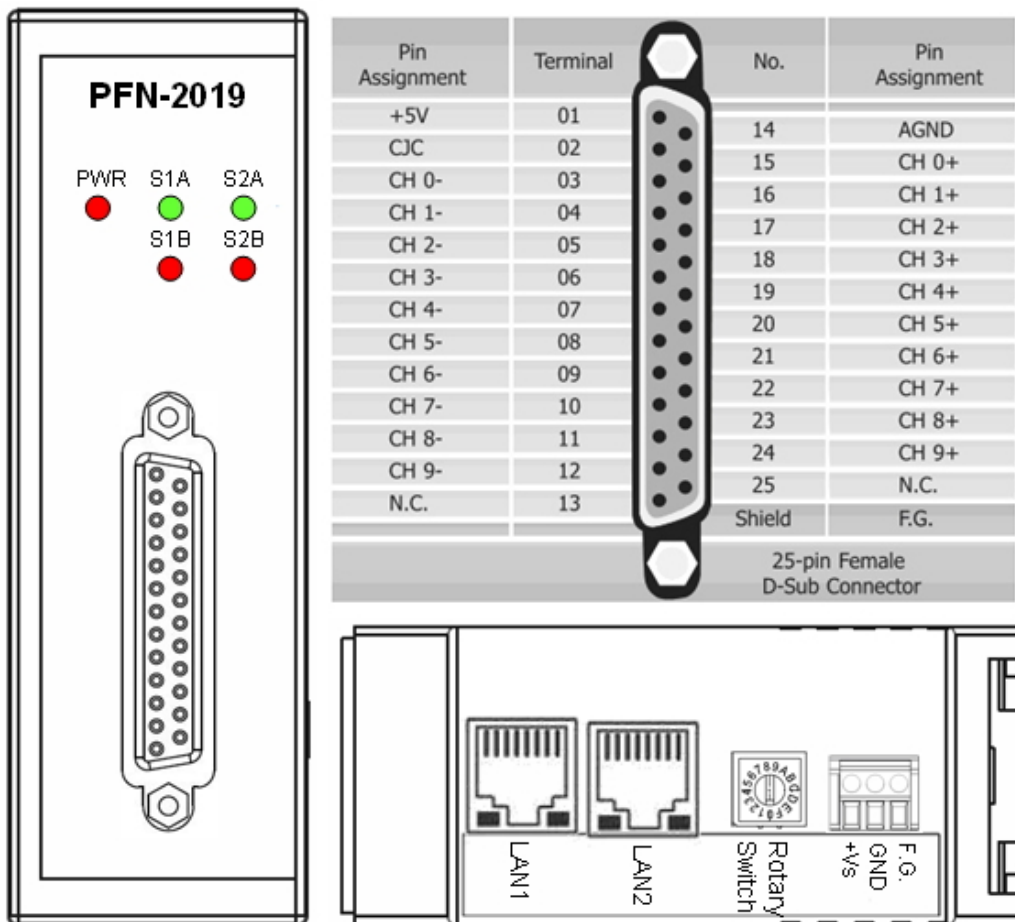

Analog Input	
Channels	10 channel differential
Input Range	+/-15mV, +/-50mV, +/-100mV, +/-500mV, +/-1V, +/-2.5V, +/-5V, +/-10V +/-20mA, 0~20mA, 4~20mA (Jumper Selectable), Thermocouple Type: J, K, T, E, R, S, B, N, C
Resolution	16 bit
Sample Rate	10 samples/second (1 channel)
Accuracy	+/- 0.1% of FSR
Open Wire Detection	Yes

1.4. Internal I/O Structure

1.4.1. PFN-2042

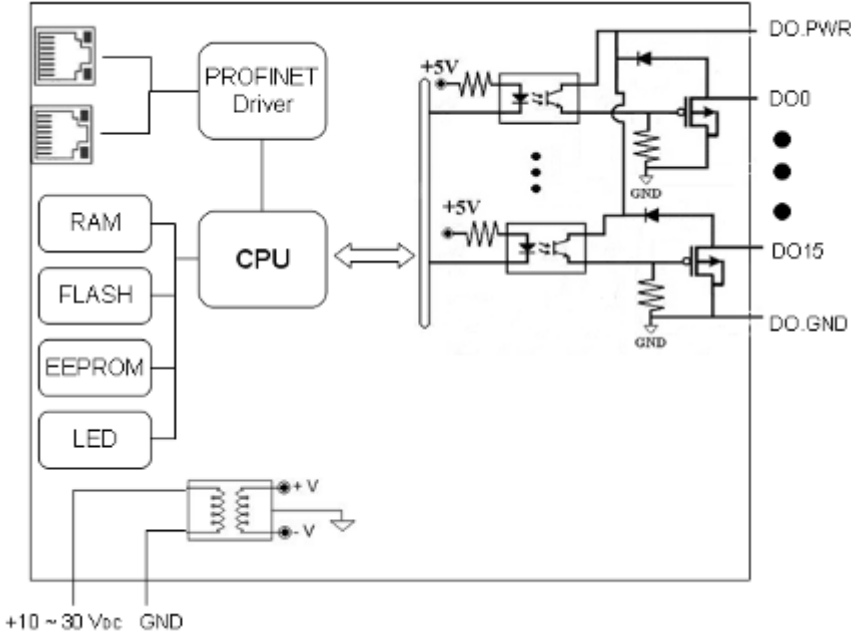

1.4.2. PFN-2051

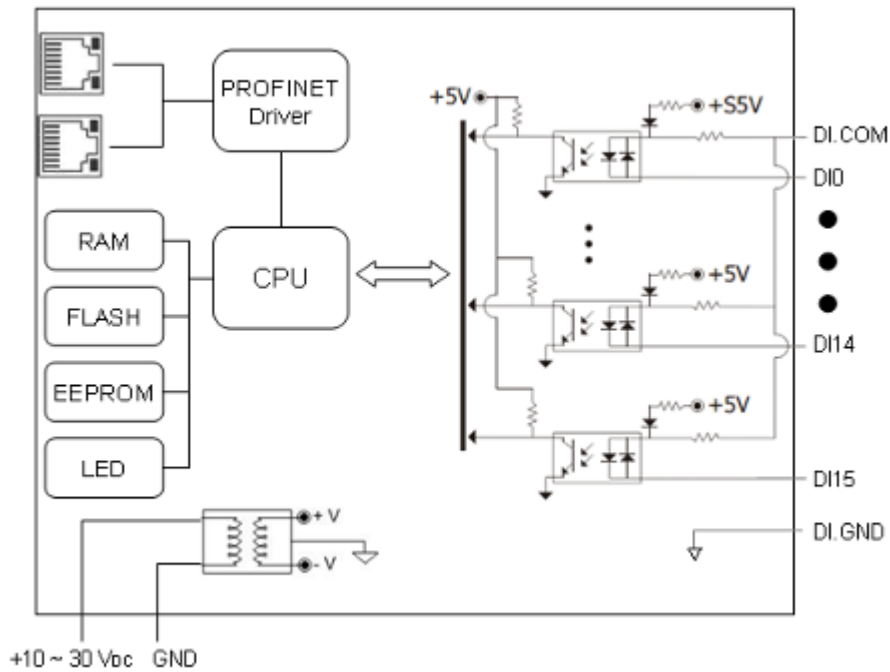

1.4.3. PFN-2052

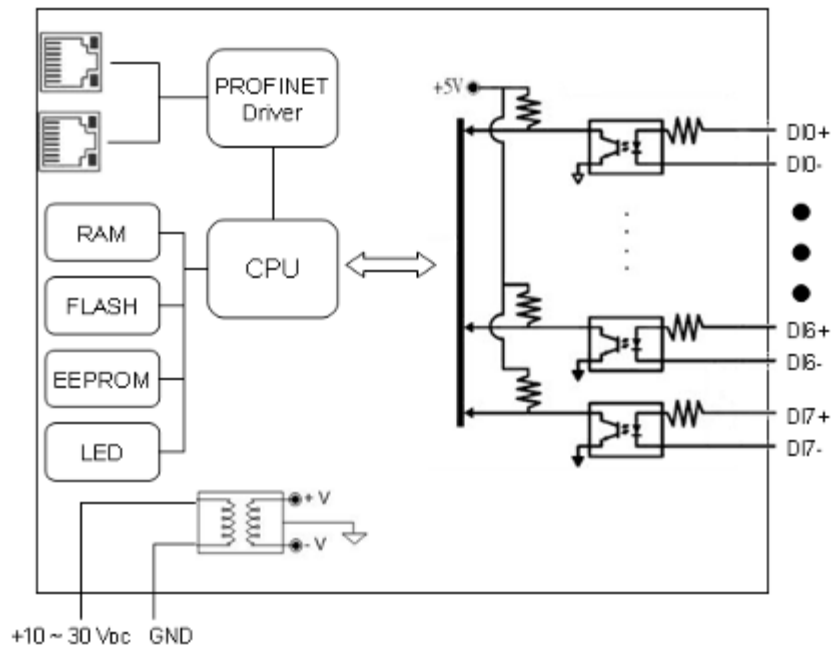

1.4.4. PFN-2053

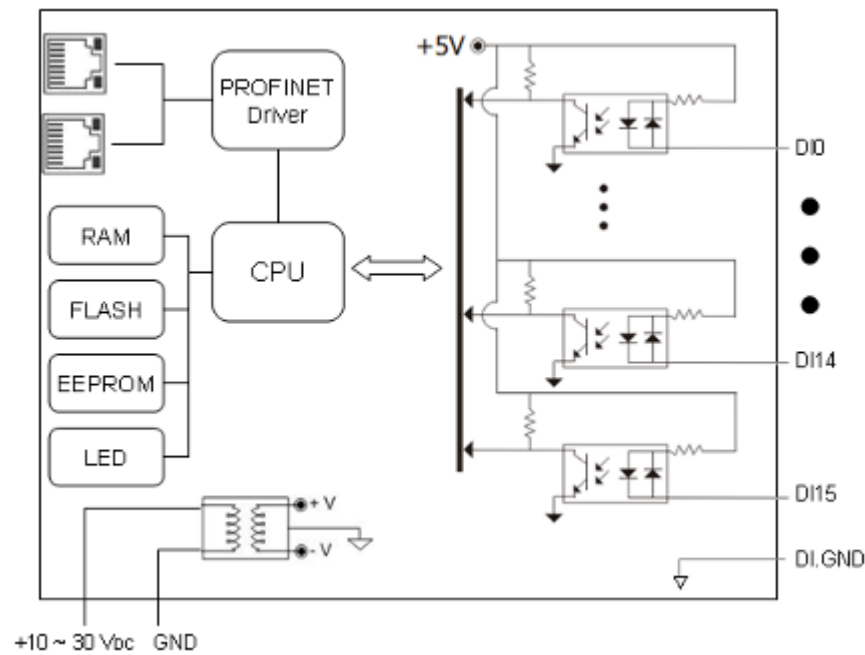

1.4.5. PFN-2055

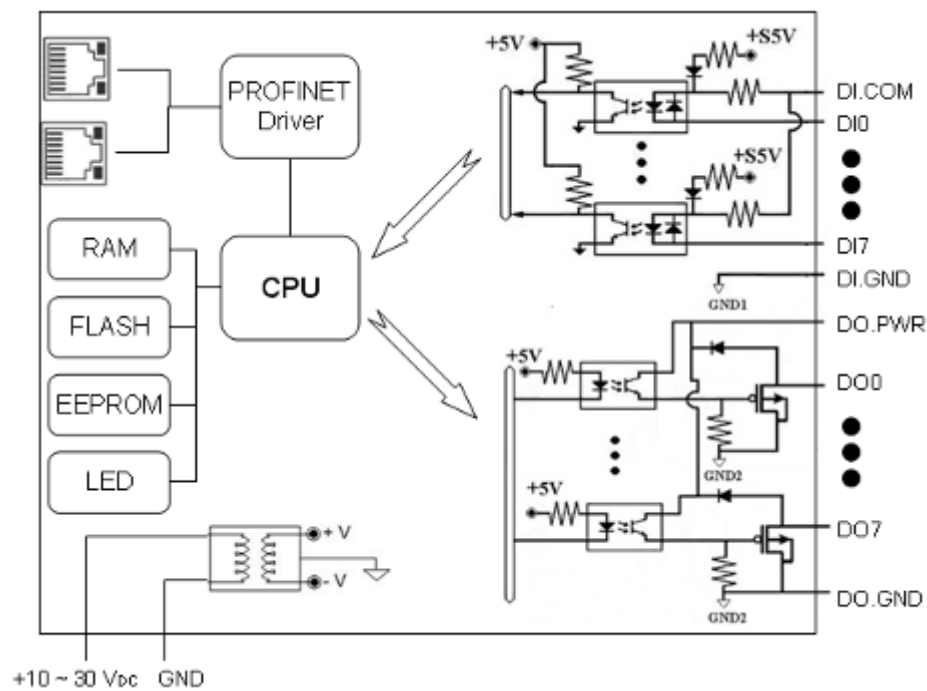

1.4.6. PFN-2060

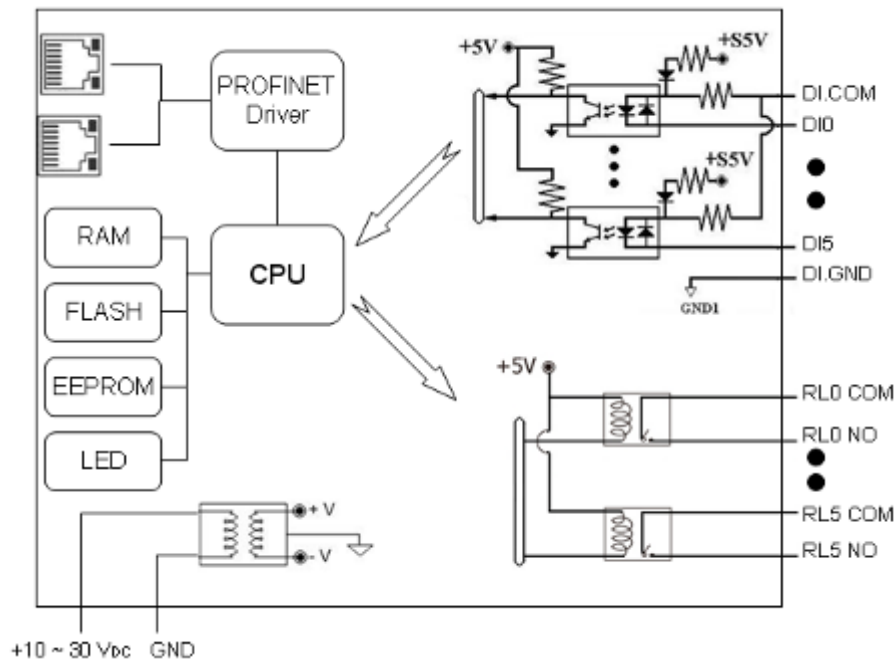

1.4.7. PFN-2019

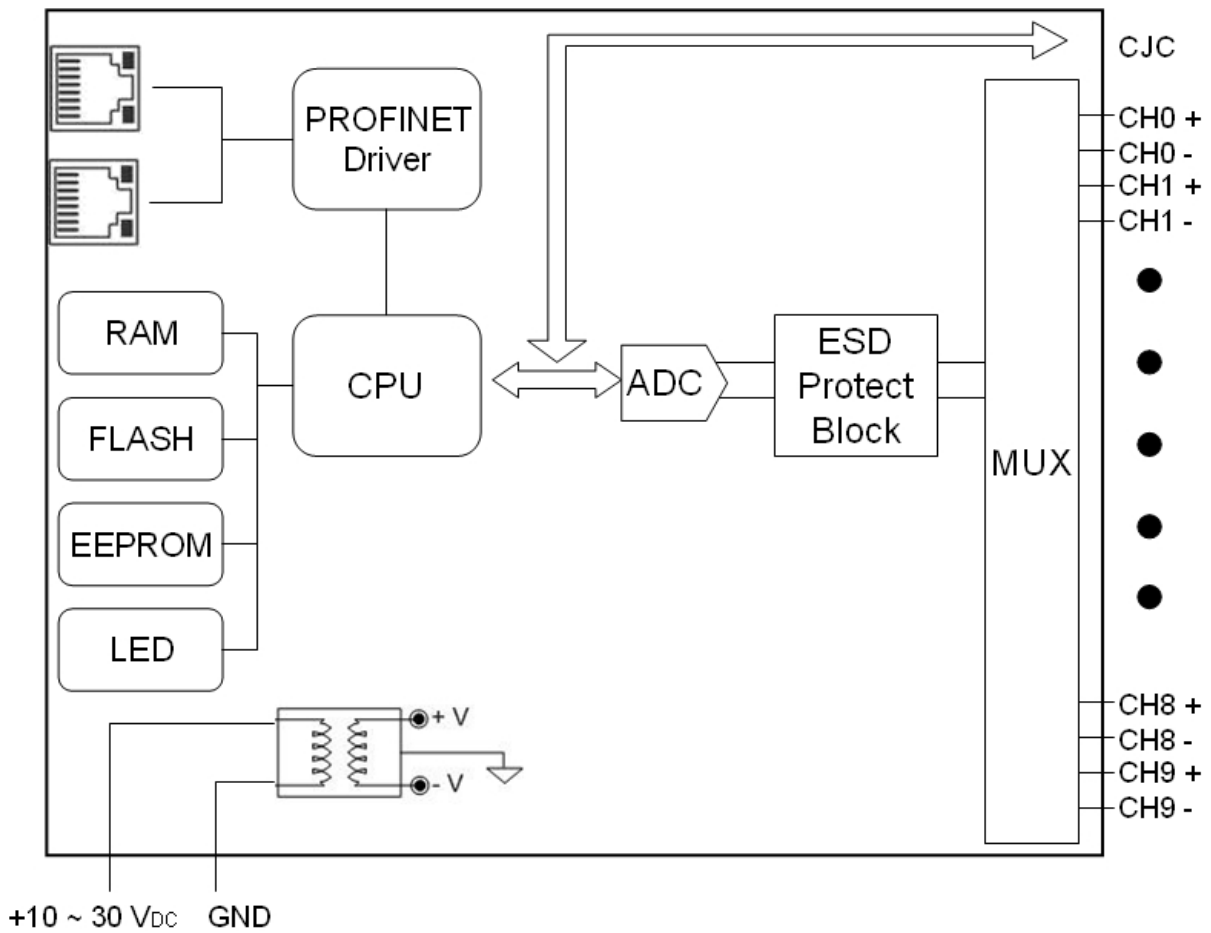

1.5. Wiring Connection

1.5.1. PFN-2042

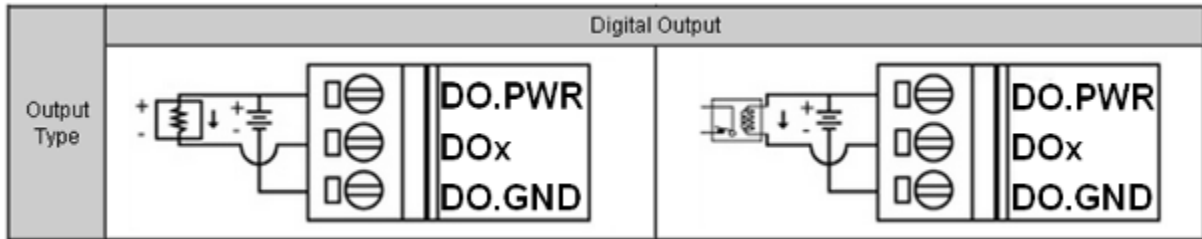

1.5.2. PFN-2051

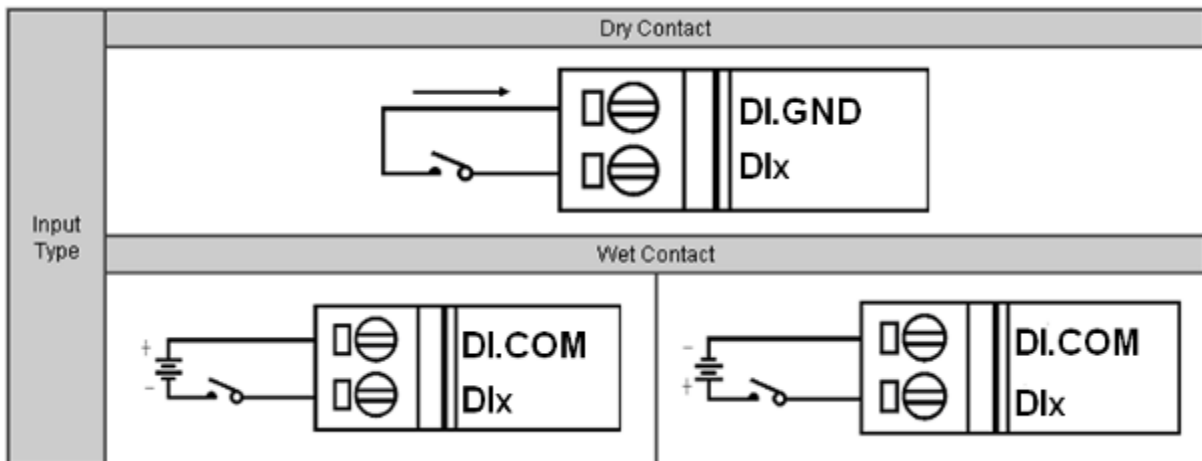

1.5.3. PFN-2052

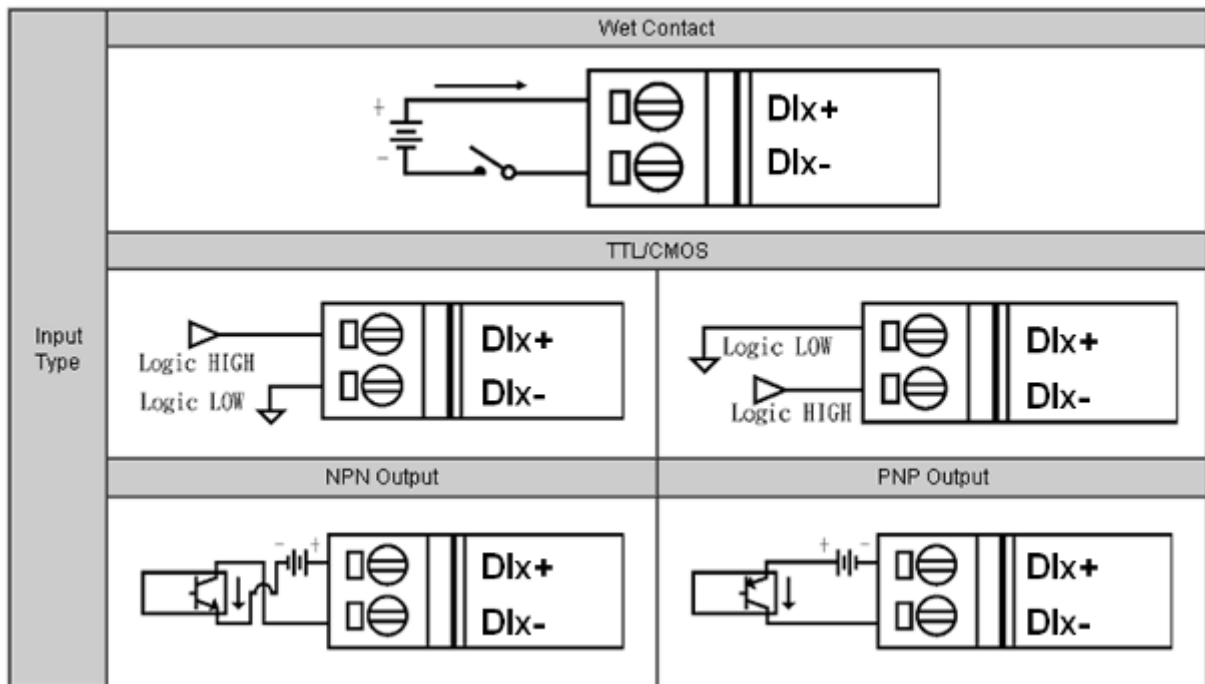

1.5.4. PFN-2053

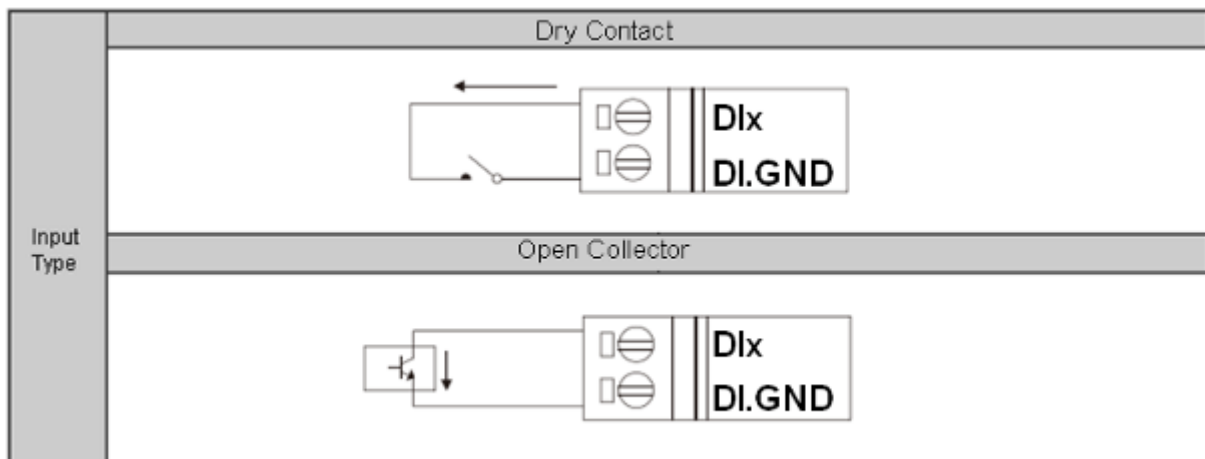

1.5.5. PFN-2055

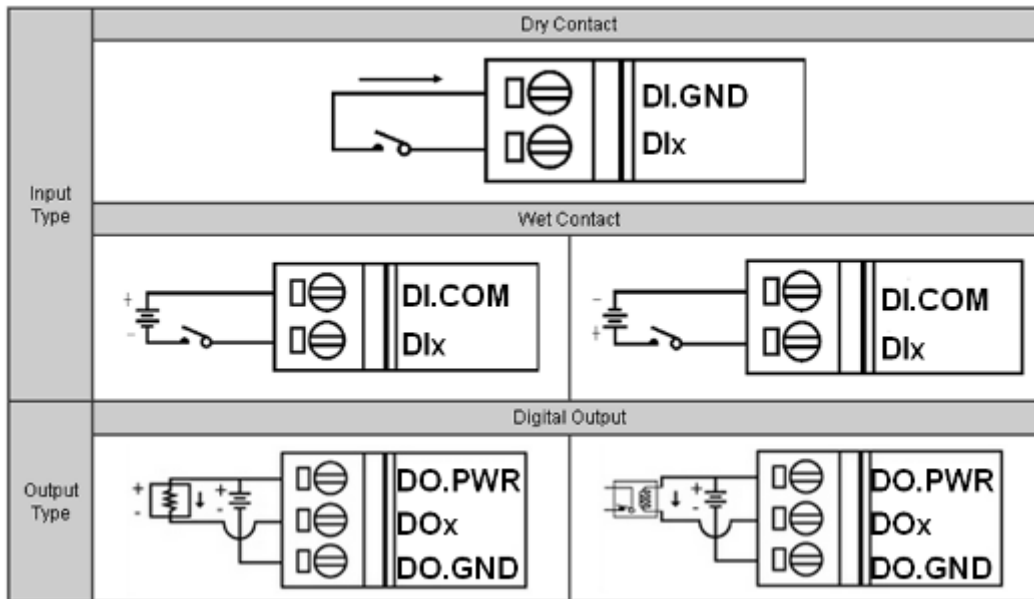

1.5.6. PFN-2060

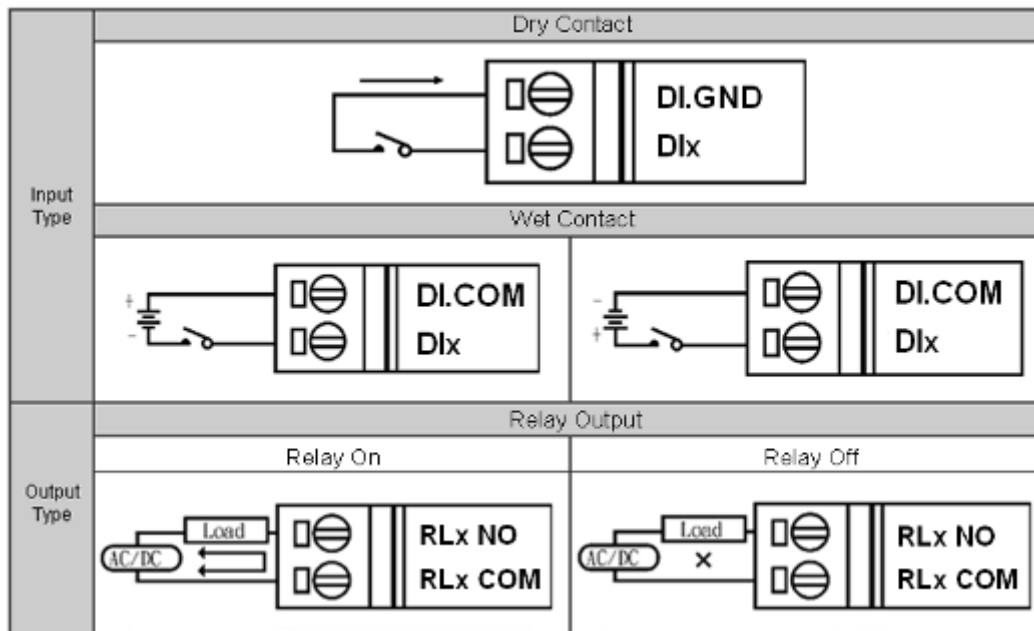

1.5.7. PFN-2019

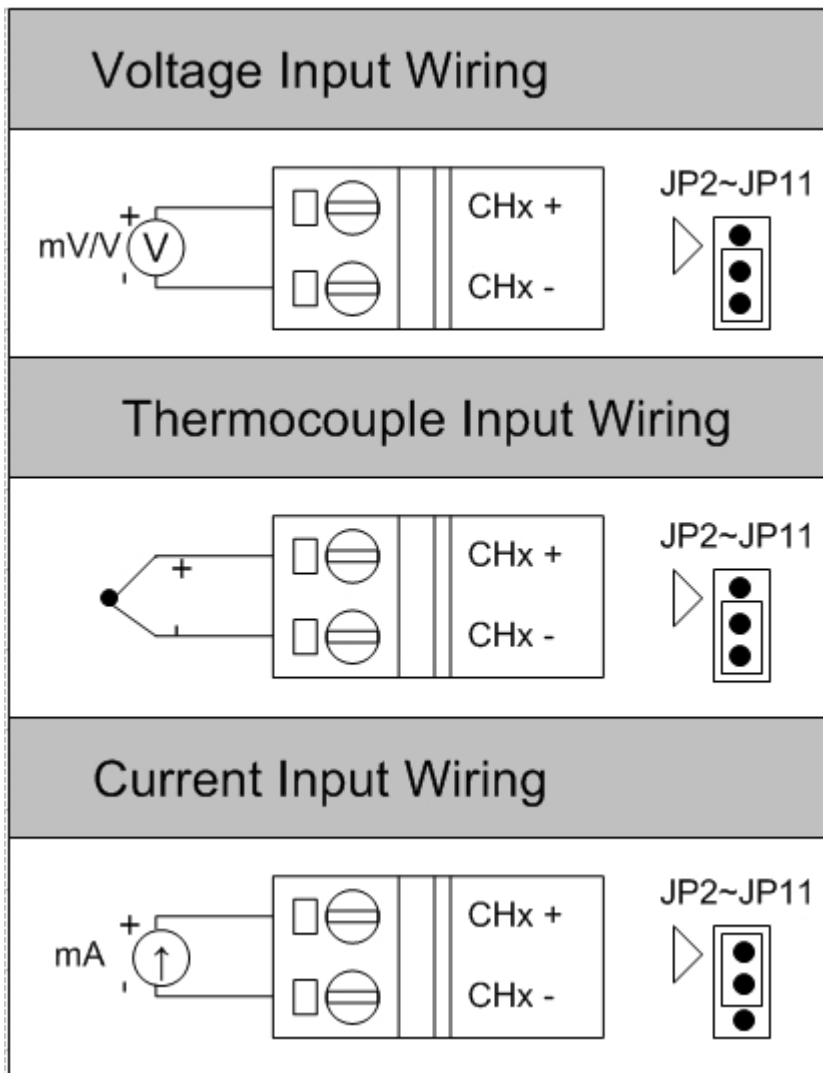

1.6. Overview

Here is a brief overview of the components and its descriptions for module status.

1.6.1. Front Panel

The PFN-2000 front panel contains the I/O connector and LEDs.

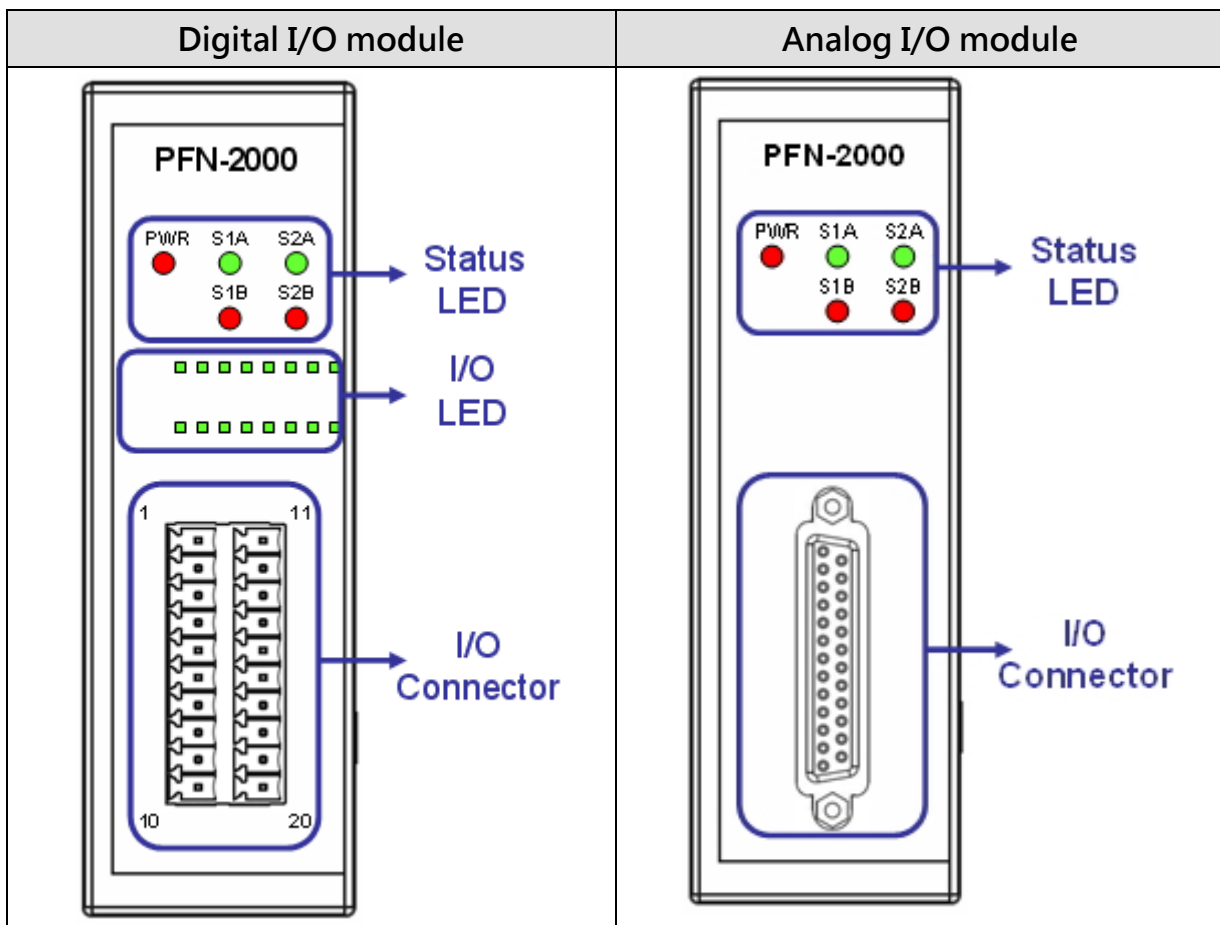

► I/O Connector

Depending on the types of the PFN-2000 modules.

For more detailed information regarding the pin assignments of the I/O Connector, please refer to "1.3.2. I/O Specification"

► Status LED Indicators

Digital I/O module:

Name	LED Action	Description
PWR	ON	The power supply is OK.
	OFF	The power supply is failed.
S1	A=ON B=OFF	Device is at Run mode.
	A=ON B=ON	Device is at Bootloader mode.
	A=ON B=Flash	Device is at Run mode and the module received the incorrect parameters.
	A=Flash B=Any	Receive a Flash LED command.
S2	A=OFF B=ON	Bootloader mode: Ethernet link established, waiting for IP address acquired
	A=OFF B=Flash	Bootloader mode: waiting for Ethernet link Run mode: waiting for Profinet connection
	A=ON B=OFF	The connection is established.
	A=Flash B=OFF	Bootloader mode: IP address acquired, waiting for telnet connection

PFN-2019 module

Name	LED Action	Description
PWR	ON	The power supply is OK.
	OFF	The power supply is failed.
	Flash	Run mode: Hardware authentication error! Bootloader mode: at Bootloader mode.
S1	A=ON B=OFF	Device is at Run mode.
	A=ON B=Flash	Flash(0.1Sec): Hardware authentication error! Flash(0.5Sec): Device is at Run mode and the module received the incorrect parameters.
	A=ON B=ON	Device is at Bootloader mode.
S2	A=OFF B=Flash	Bootloader mode: waiting for Ethernet link Run mode: waiting for Profinet connection
	A=ON B=OFF	The connection is established.
	A=OFF B=ON	Bootloader mode: Ethernet link established, waiting for IP address acquired
	A=Flash B=OFF	Bootloader mode: IP address acquired, waiting for telnet connection

► **I/O LED Indicators**

Depending on the types of the PFN-2000 modules.

For more detailed information, please refer to “1.3.2. I/O Specification”

1.6.2. Top Panel

The PFN-2000 top panel contains the Ethernet port, rotary switch and power connector.

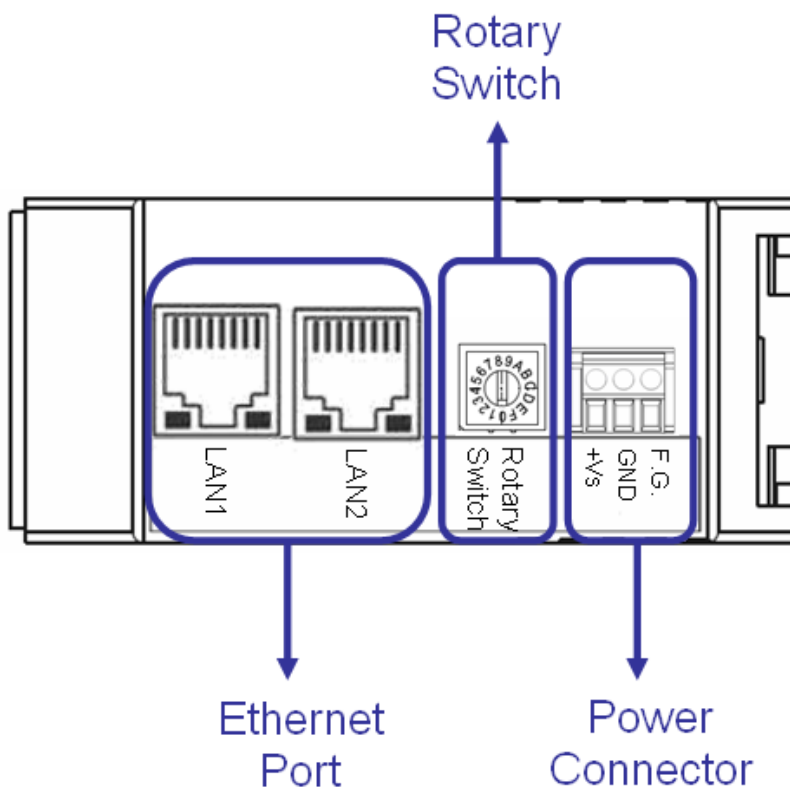

► Ethernet Ports

An Ethernet port is an opening on PFN-2000 network equipment that Ethernet cables plug into. Ethernet ports accept cables with RJ-45 connectors.

Tips & Warnings



1. When users connect PFN-2000 and switch, users should not connect LAN1 and LAN2 to switch at the same time, else it will lead to abnormal network.
2. When users connect network devices by daisy chain topology, users can connect these devices in series by LAN1 and LAN2.

► Rotary Switch

Digital I/O module:

Position	Mode	Power ON Value	Safe Value
0	Run mode	Low	Retain
1	Run mode	Low	Low
2	Run mode	Low	High
3	Run mode	High	Retain
4	Run mode	High	Low
5	Run mode	High	High
6	Run mode	User Defined	User Defined
7	Run mode	Reserved	Reserved
8~F	Bootloader mode	N/A	N/A

PFN-2019 module:

Mode	Position
Run mode	0~7
Bootloader mode	8~F

► Power Connector

Pin Name	Function
+VS	10 ~ 30 VDC power input
GND	Ground connection
F.G.	Frame ground connection

1.7. Dimensions

Digital I/O module:

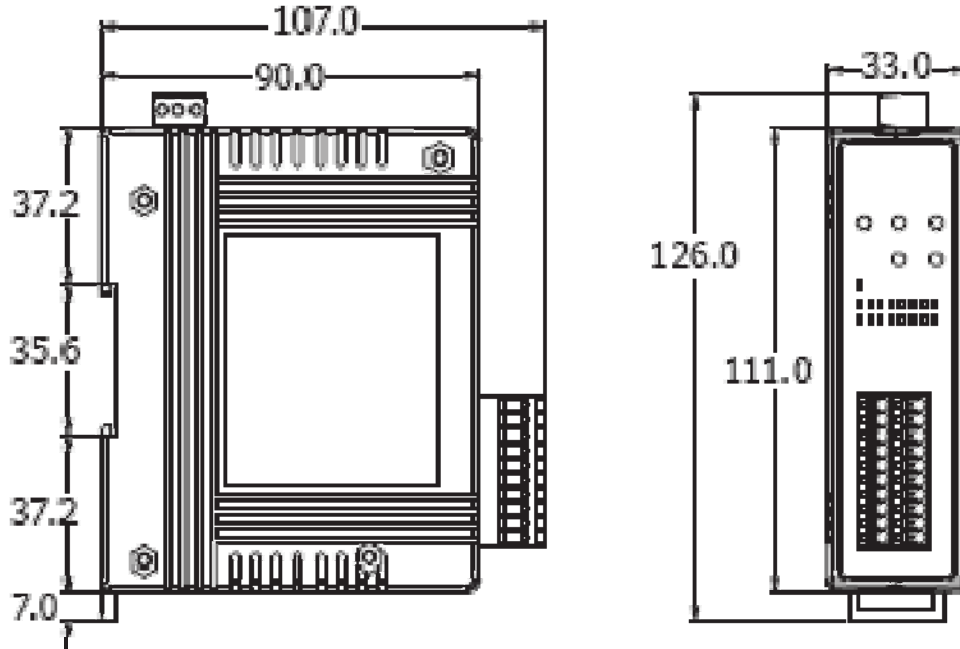

PFN-2019 module:

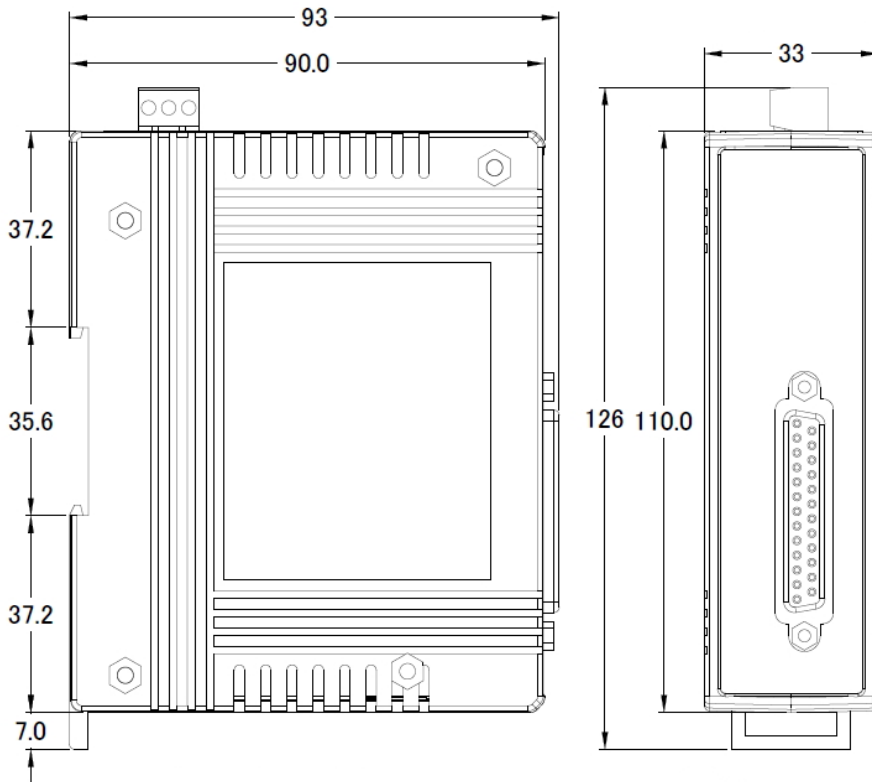

2. PROFINET

PROFINET contains 2 different solutions. They are PROFINET IO and PROFINET CBA (Component Based Automation). **PFN-2000 series modules are PROFINET IO devices.**

PROFINET IO is used for communication with decentral periphery like IOs, drives, etc.

PROFINET CBA is a communication solution for autonomously acting partial units of machines or plants.

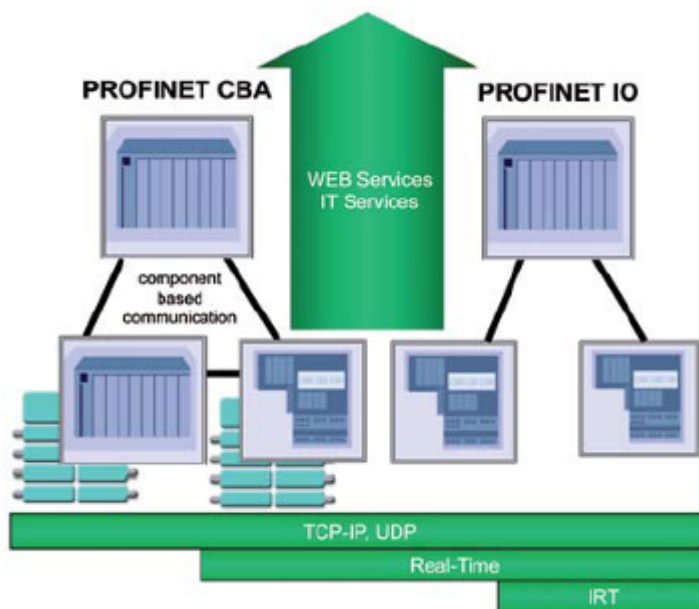

2.1. Device classes of PROFINET IO

The following devices classes are defined to facilitate structuring of PROFINET IO field devices.

- ◆ IO-Controller: This is typically a PLC on which the automation program runs
- ◆ IO-Supervisor: This can be a programming device (PG), personal computer (PC), or human machine interface (HMI) device for commissioning or diagnostic purposes.
- ◆ IO-Device: An IO-Device is a distributed I/O field device that is connected via PROFINET IO. It can exchange data with multiple IO-Controllers.

PFN-2000 User Manual (Version 1.30, Sep/2014)

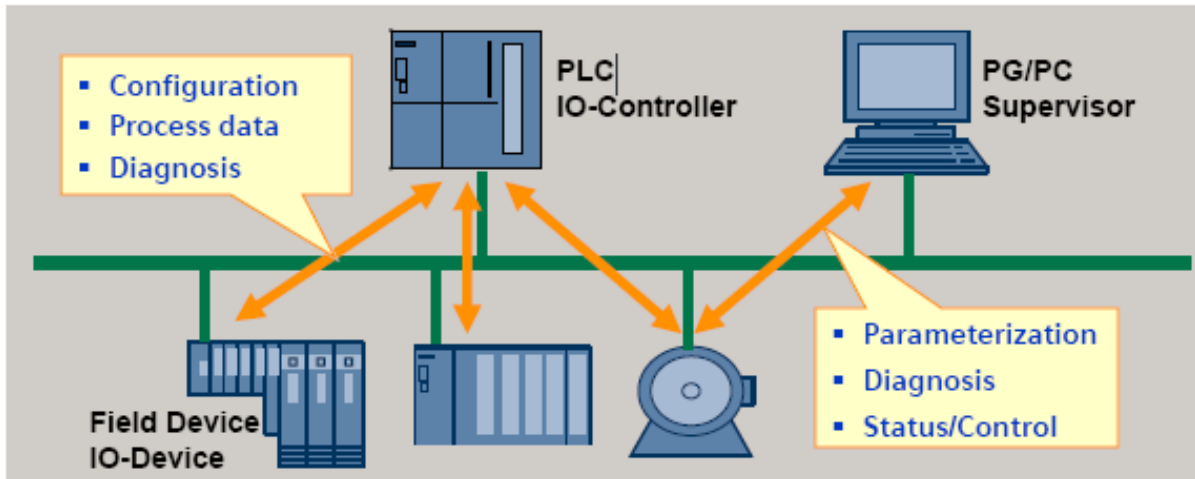

2.2. Device Description

The functionality of a PROFINET IO Device is always described in a GSD file. This file contains all data that are relevant for engineering as well as for data exchange with IO-Device.

PROFINET IO-Devices can be described using XML-based GSD. The description language of the GSD file, i.e. GSDML (General Station Description Markup Language) is based on international standards.

Every manufacturer of a PROFINET IO-Device must supply an associated GSD file according to the GSDML specification. Users can access and configure PFN-2000 series modules by using the GSDML file in any PROFINET Engineering tool.

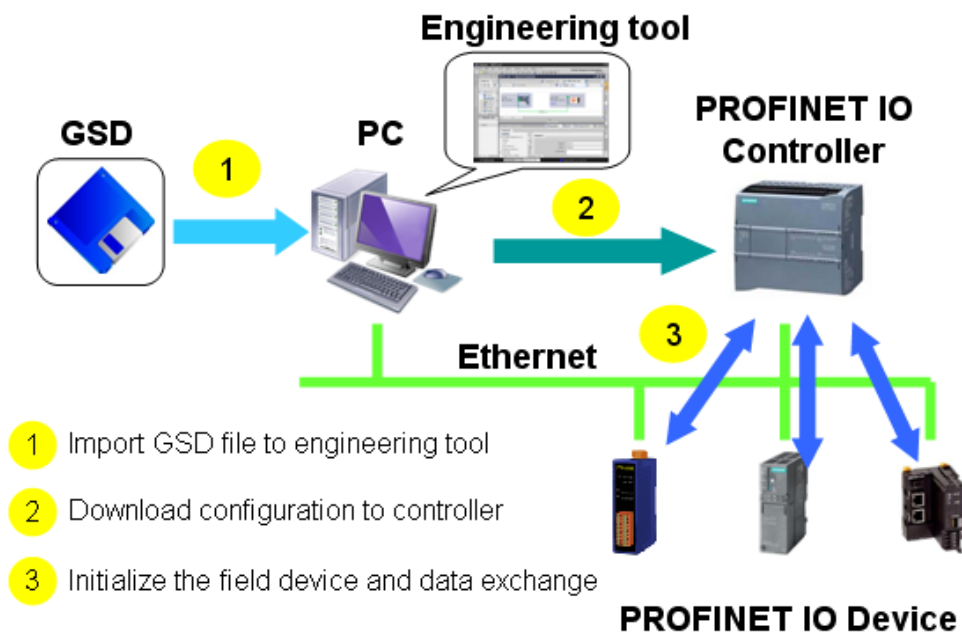

PFN-2000 User Manual (Version 1.30, Sep/2014)

2.3. Conformance Classes (CC)

PI has classified the scope of functions in PROFINET IO into 3 conformance classes (CC-A, CC-B, CC-C). Users simply need to select a CC appropriate for system and do not need to worry about any other details to ensure the interoperability in an automation system with regard to the scope of functions and performance parameters.

CC-A:

Use of the infrastructure of an existing Ethernet network including integration of basic PROFINET functionality. All IT services can be used without restrictions. Examples of typical applications are in building automation and process automation. Wireless communication is only possible in this class.

CC-B:

In addition to the functions of CC-A, the scope of functions of CC-B supports easy and user-friendly device replacement without the need for an engineering tool. Examples of typical applications are in automation systems with a higher-level machine controller that place relatively low demands for a deterministic data cycle.

CC-C:

In addition to the functions of CC-B, the scope of functions of CC-C supports high-precision and deterministic data transmission, including for isochronous applications. An example of a typical application is the field of motion control.

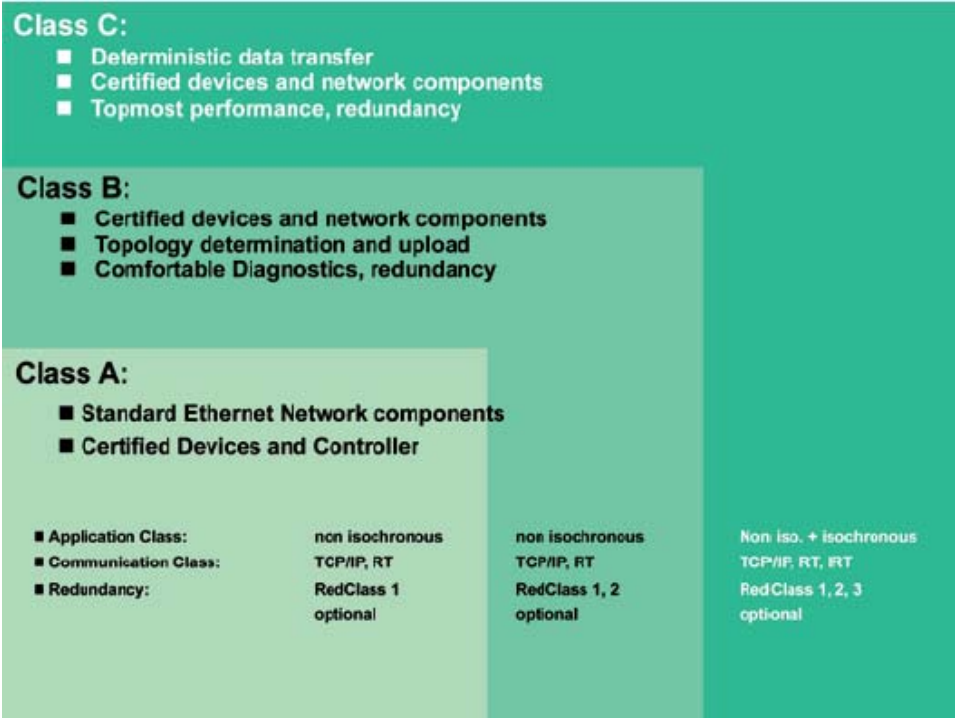

3. Basic Application

If you are a new user, begin with this chapter, it includes a guided tour that provides a basic overview of installing, configuring and using the PFN-2000.

In the following examples the S7-1200 PLC from Siemens is used to be a PROFINET IO Controller. The configuration and communication is done by the program “Step 7 V11 SP2 (TIA PORTAL)” provided by Siemens.

3.1. Connect to Network, PC and PROFINET IO controller

The PFN-2000 series modules are equipped with two RJ-45 Ethernet ports for connection to an Ethernet switch, PC and PROFINET IO controller.

Tips & Warnings



1. When users connect PFN-2000 and switch, users should not connect LAN1 and LAN2 to switch at the same time, else it will lead to abnormal network.
2. When users connect network devices by daisy chain topology, users can connect these devices in series by LAN1 and LAN2.

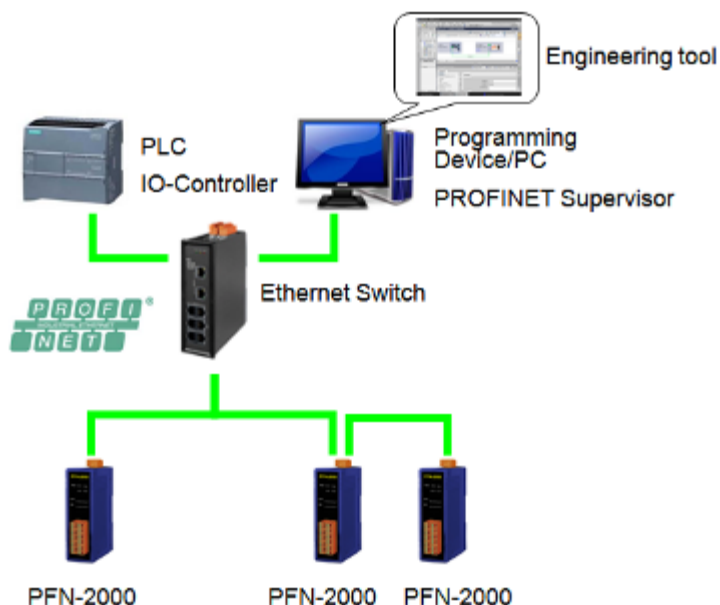

3.2. Network configuration

In this example, please follow the below configuration to configure the network.

PC:

IP: 192.168.6.210

Mask: 255.255.0.0

PLC:

Device name: plc1

IP: 192.168.6.211

Mask: 255.255.0.0

PFN-2000:

Device name: pfn-2000

IP: 192.168.6.212

Mask: 255.255.0.0

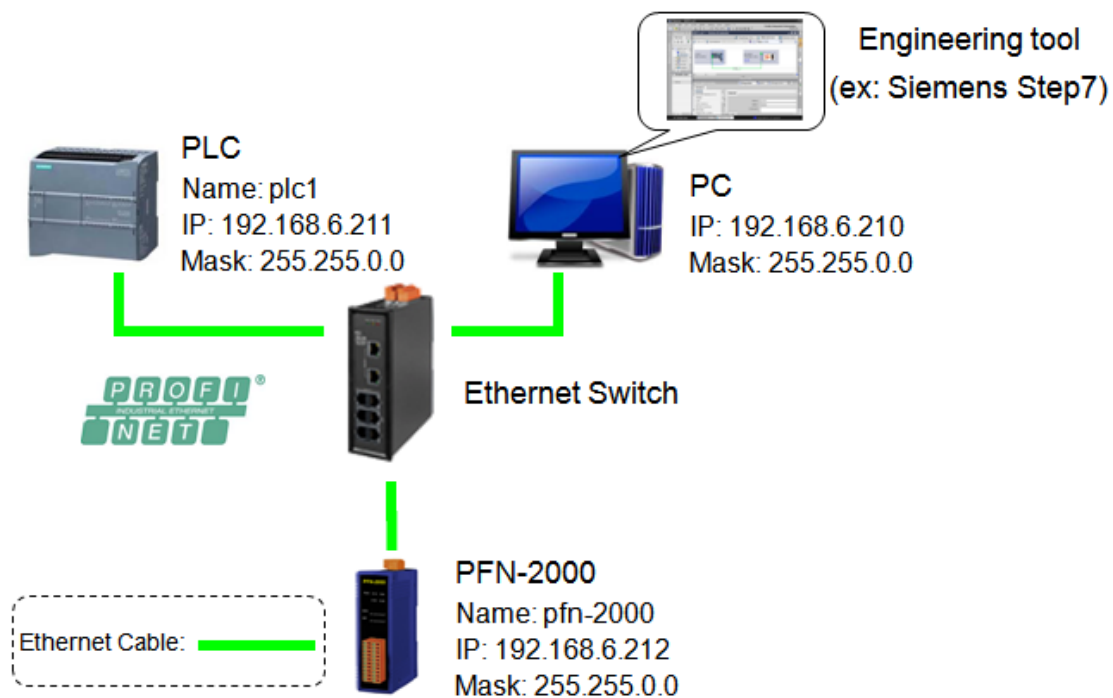

PFN-2000 User Manual (Version 1.30, Sep/2014)

Step 1: Set PC's IP

- ◆ Click “start->Settings->Network Connections”

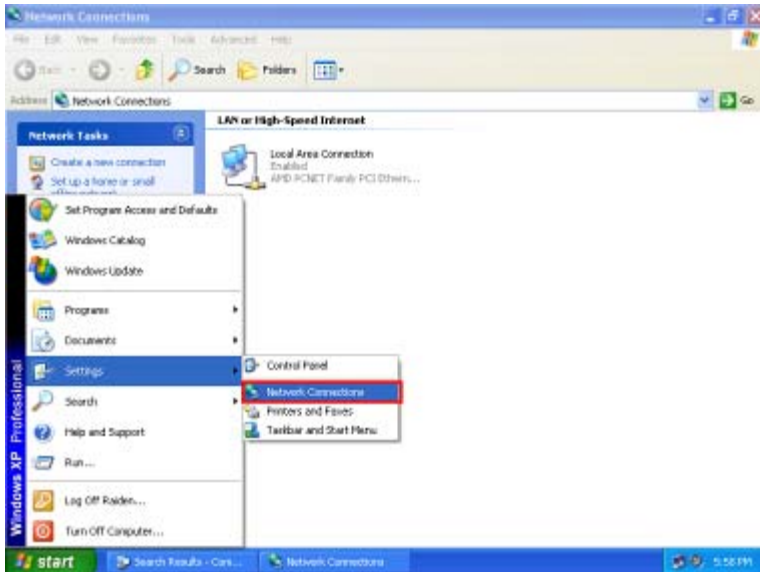

- ◆ Double click “Local Area Connection” icon



- ◆ Click “Properties” button

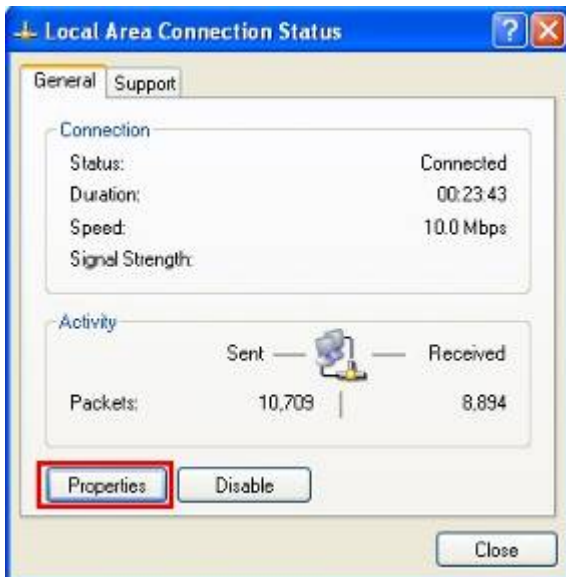

- ◆ Select “Internet Protocol(TCP/IP)” and click “Properties” button

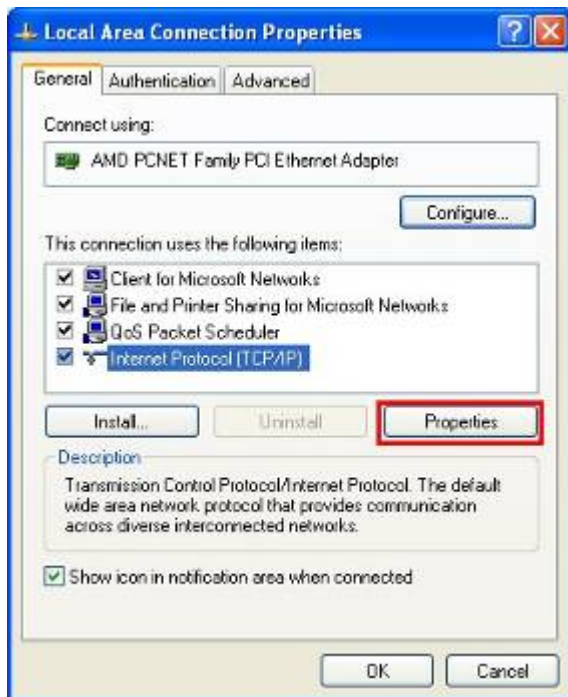

- ◆ Set “Internet Protocol Properties” and then click “OK” button.

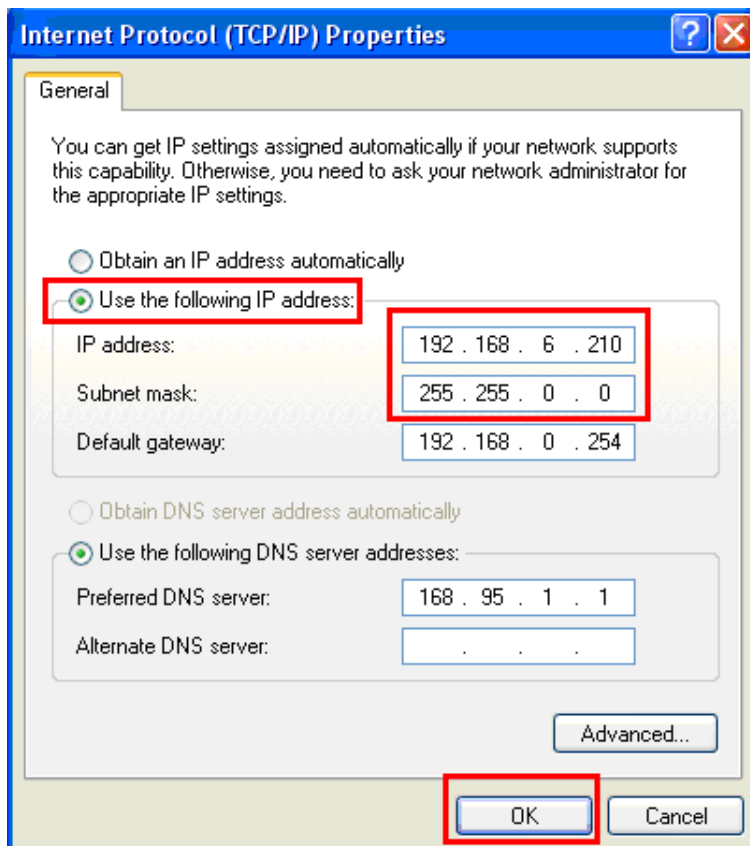

Step 2: Set PLC's name and IP

- ◆ Double Click TIA icon to start Step 7 V11



- ◆ Click "Project view"

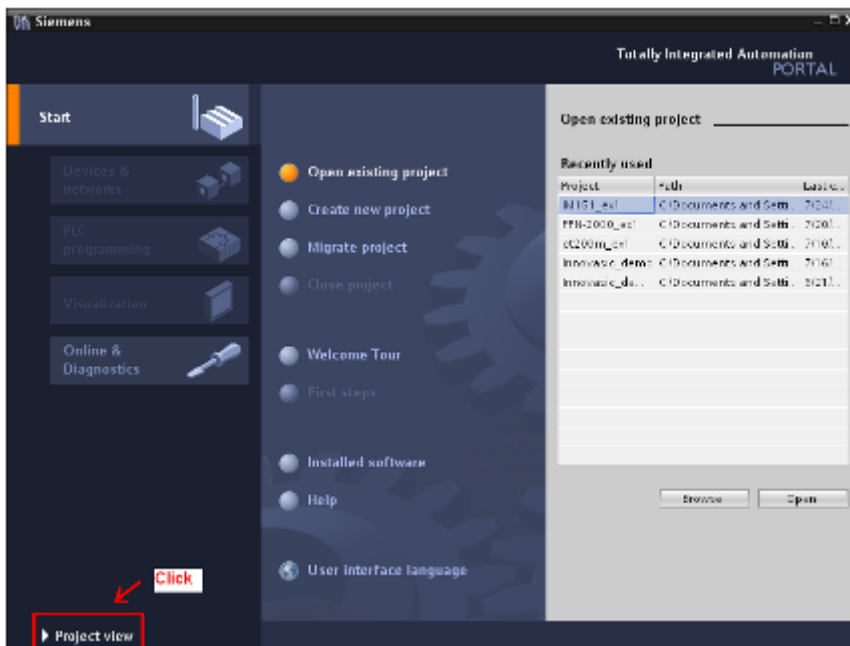

- ◆ Search accessible devices

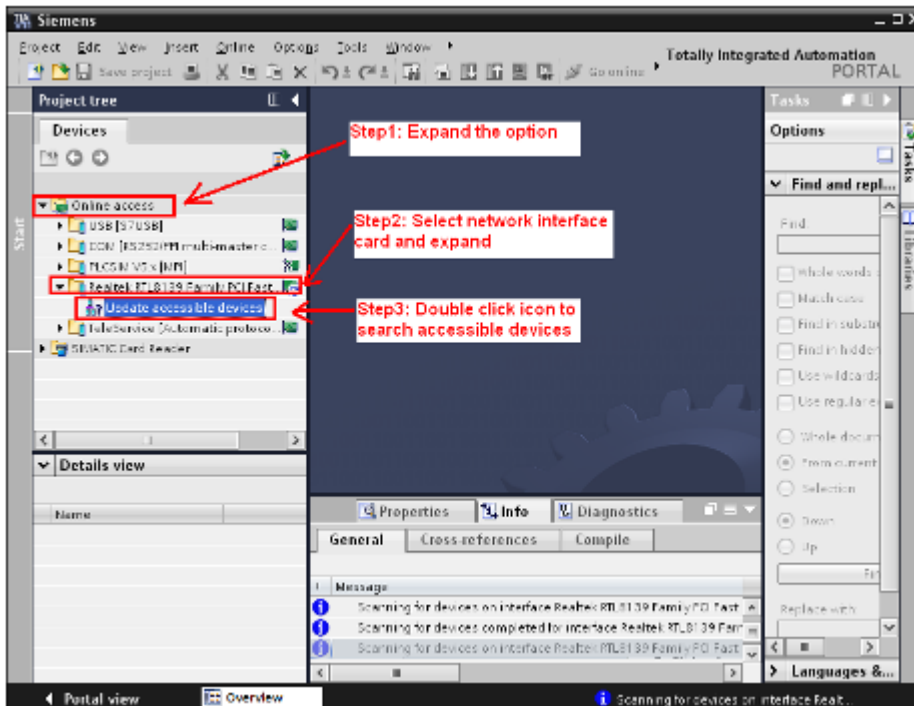

◆ Select PLC and click “Online & diagnostics” button

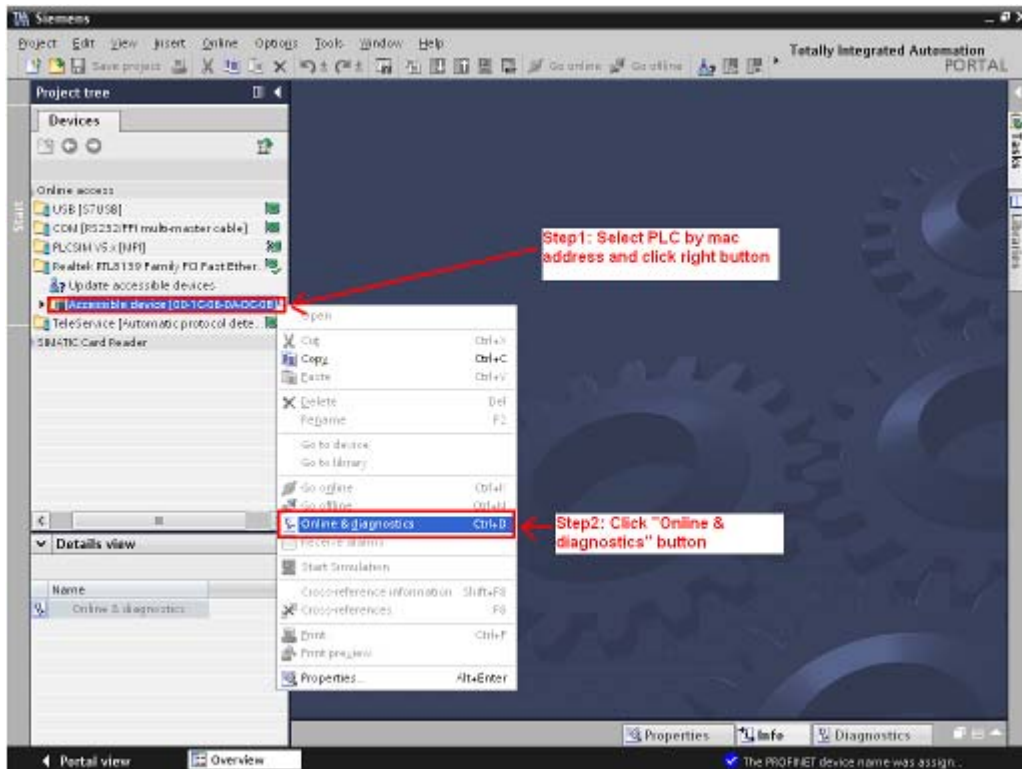

◆ Set IP and Mask

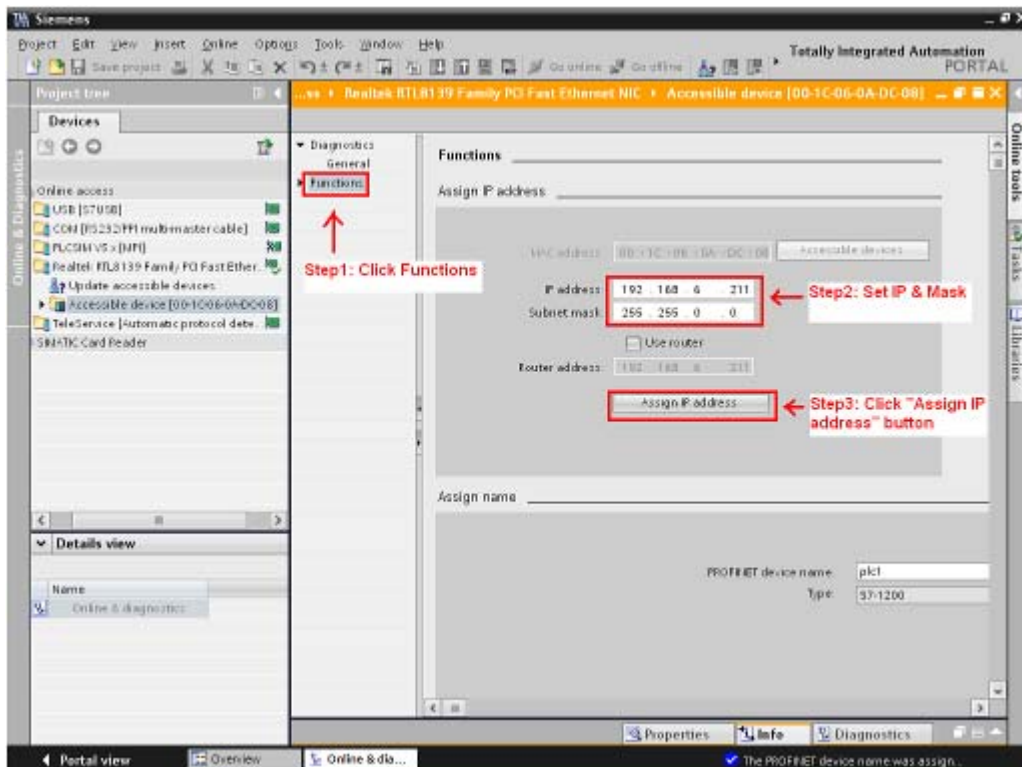

◆ Set device name

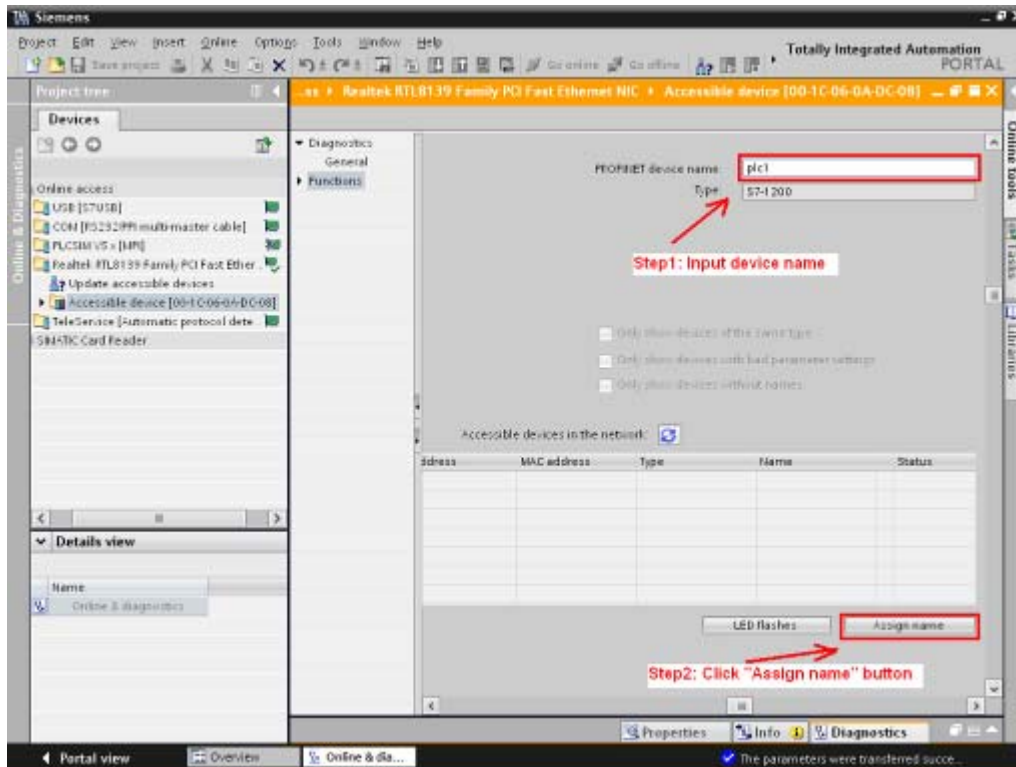

Step 3: Set PFN-2000 module's name and IP

◆ Search accessible devices

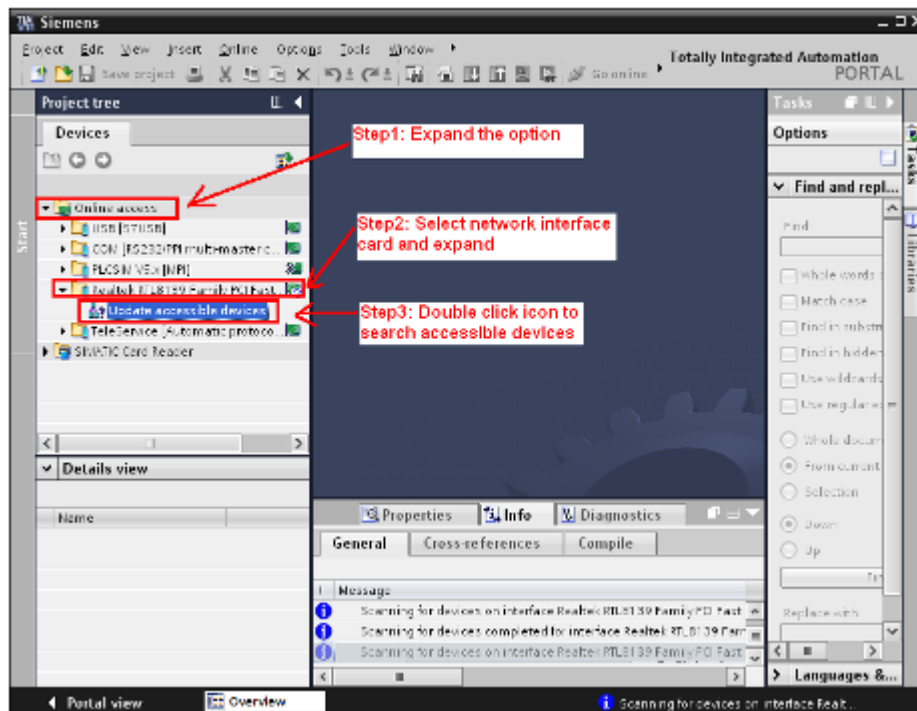

- ◆ Select PFN-2000 module and click “Online & diagnostics” button

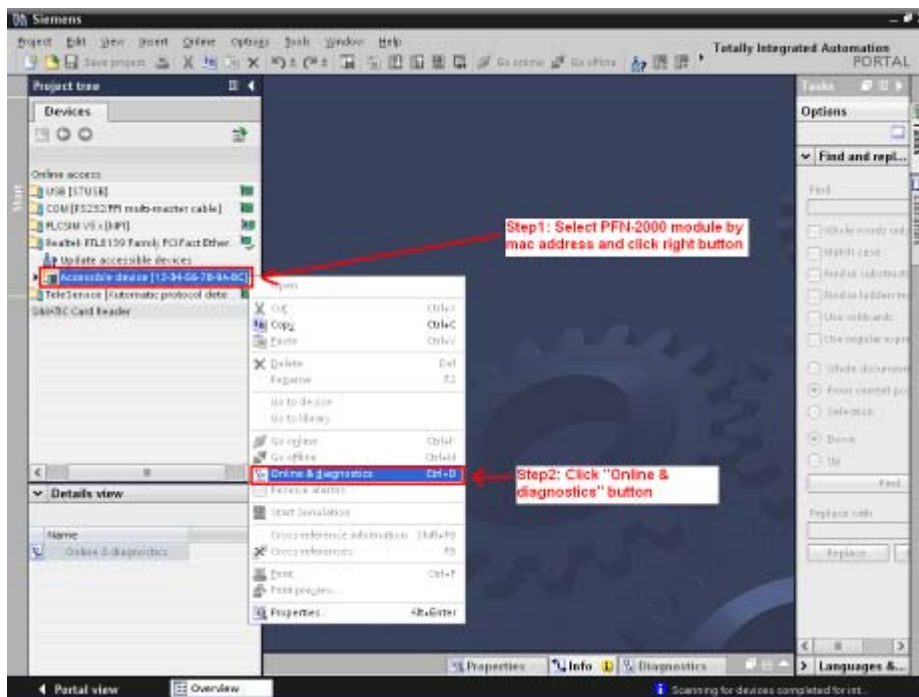

- ◆ Set IP and Mask

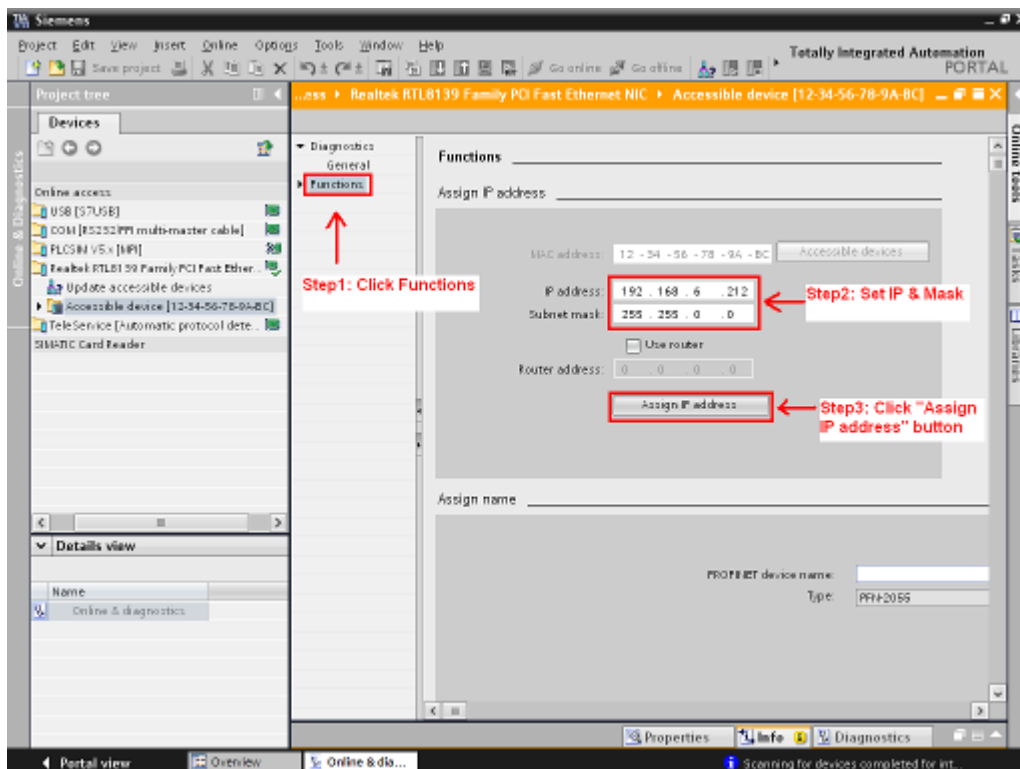

◆ Set device name

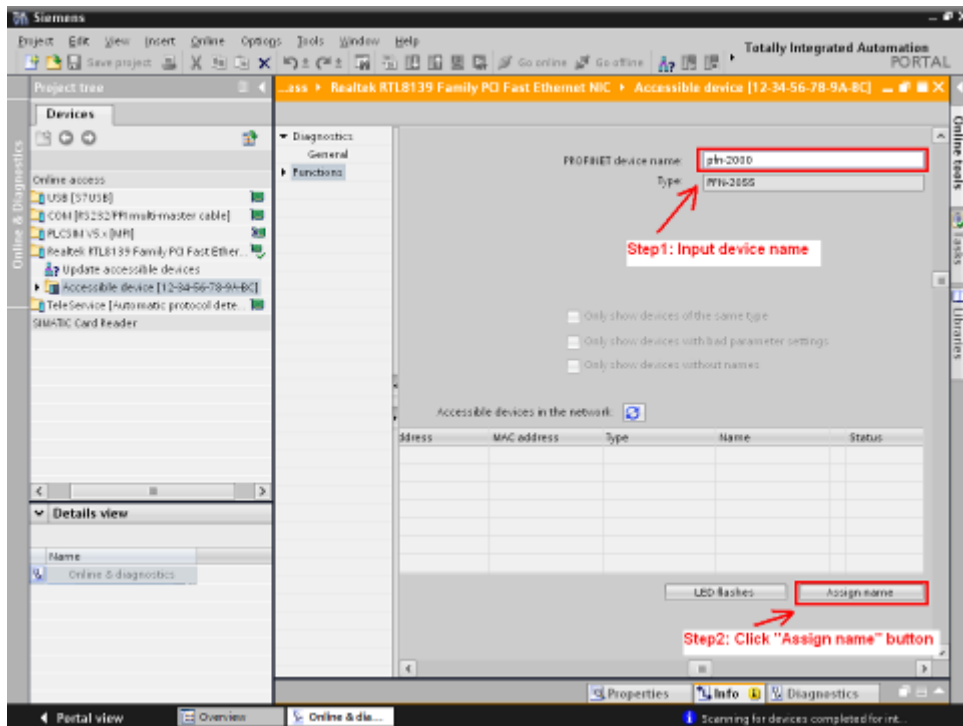

3.3. GSD Import

In this example, please follow the step to import GSD file.

Step 1: Get GSD file

The GSD file can be obtained from companion CD or our FTP site:

CD: \fieldbus_cd\profinet\remote io\pfn-2000\gsd\

ftp://ftp.icpdas.com/pub/cd/fieldbus_cd/profinet/remote%20io/pfn-2000/gsd/

Step 2: Import GSD file

◆ Double Click TIA icon to start Step 7 V11



PFN-2000 User Manual (Version 1.30, Sep/2014)

◆ Click “Project view”

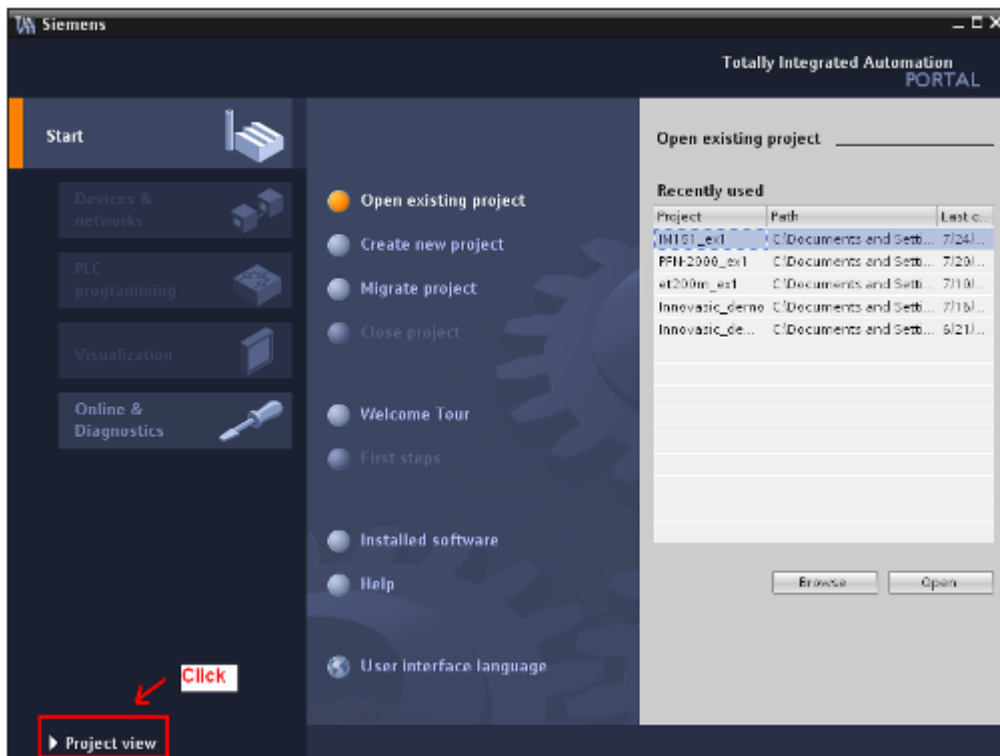

◆ Select “Menu->Options->Install general station description file (GSD)”

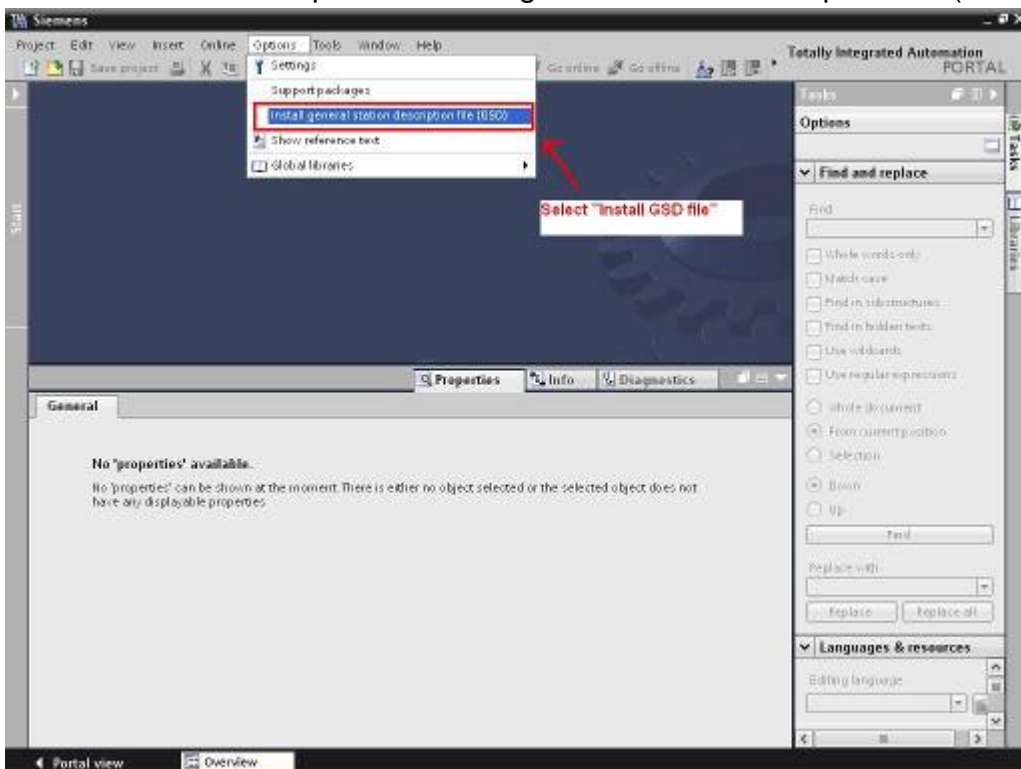

- ◆ Select and install GSD file



3.4. Project Setup

In this example, please follow the step to setup project.

Step 1: Create the project

- ◆ Double Click TIA icon to start Step 7 V11



◆ Create the Project

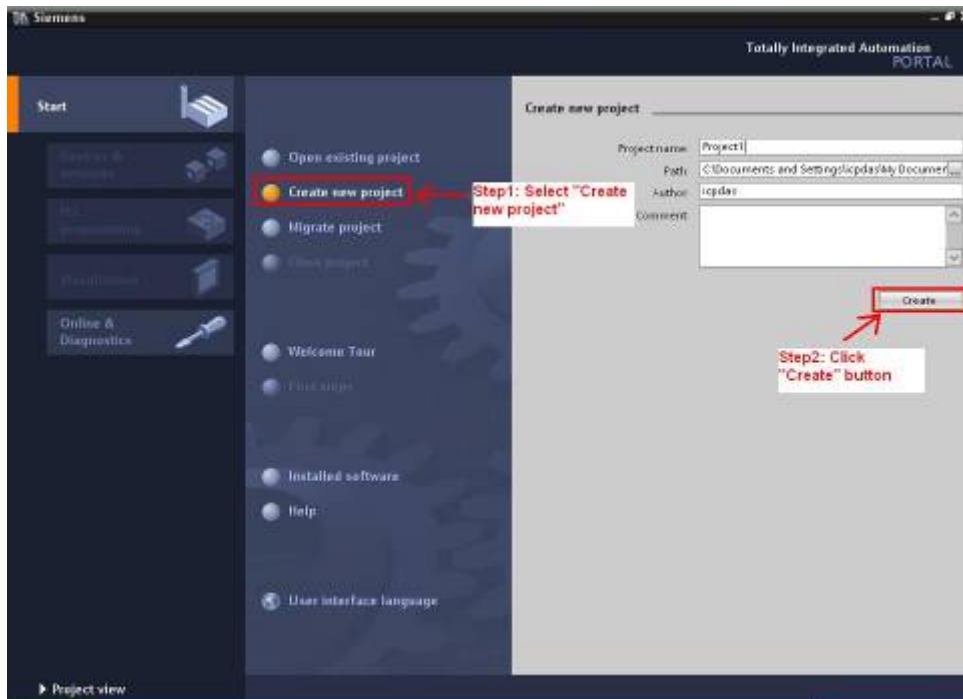

Step 2: Project configuration

◆ Add a PLC device

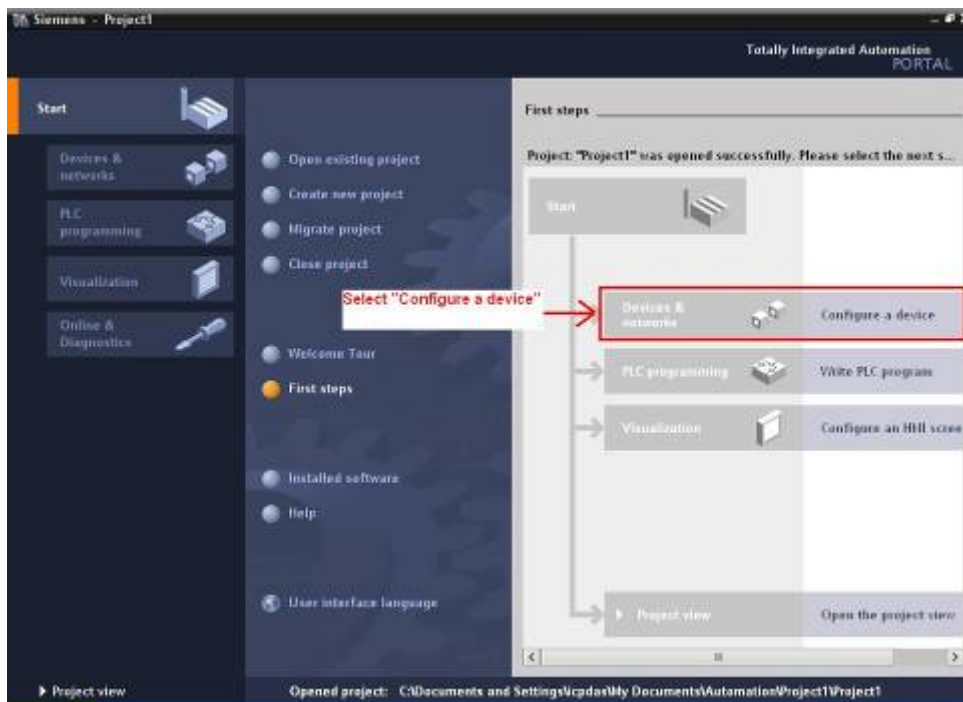

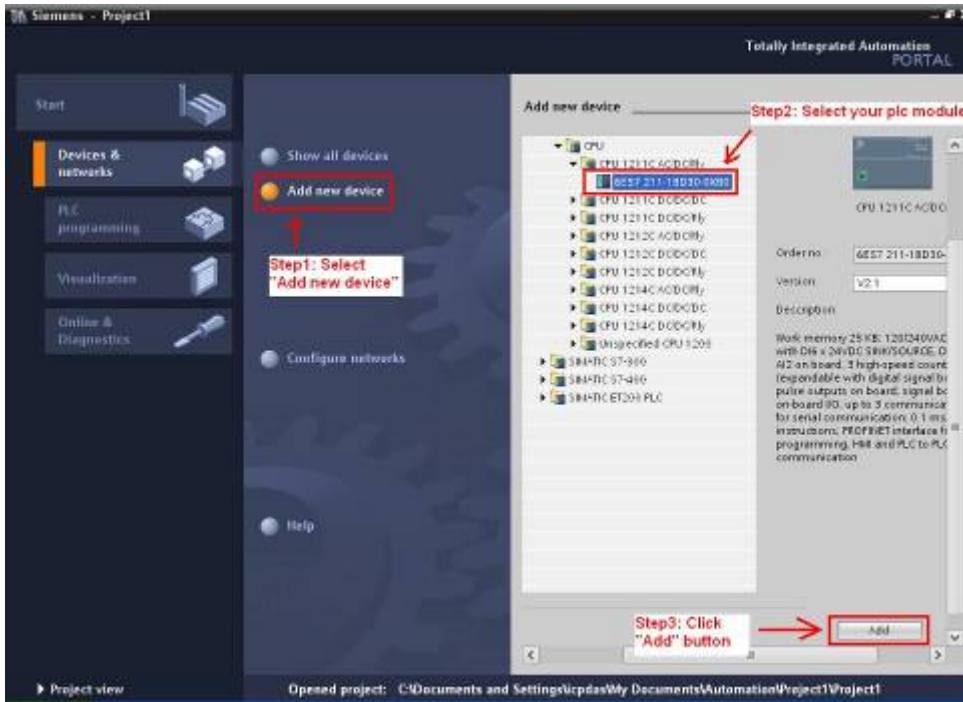

◆ Set the device name of PLC to "plc1"

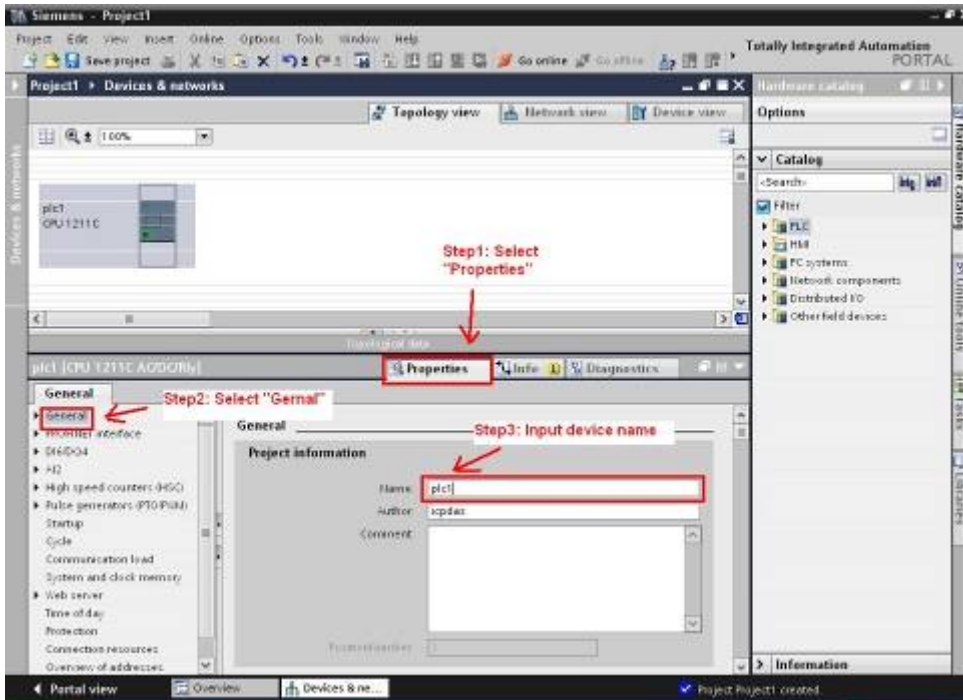

- ◆ Set the IP and mask of PLC and add a new subnet

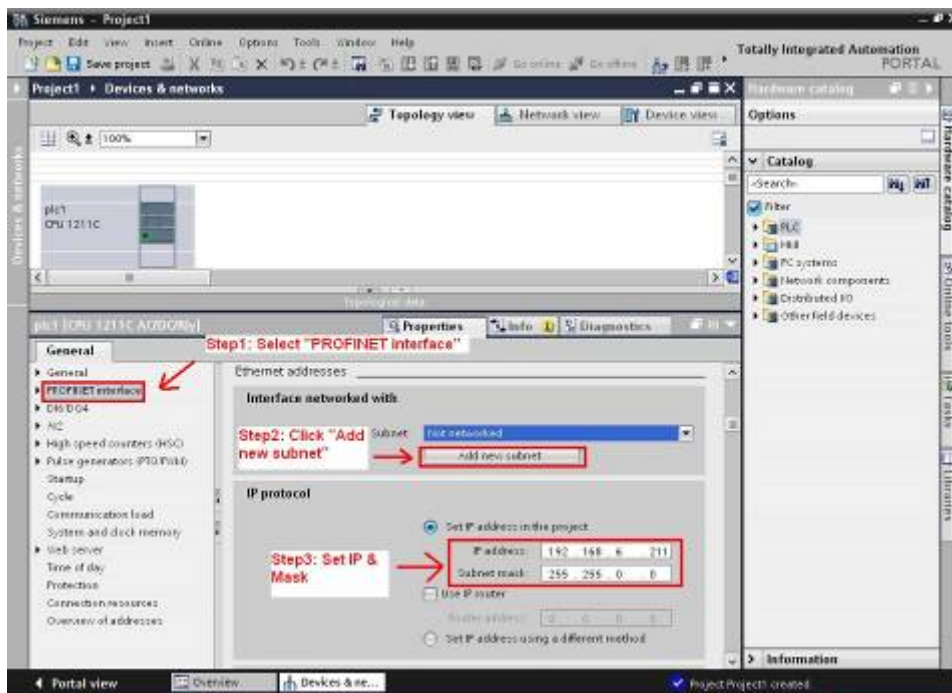

- ◆ Add PFN-2000 module

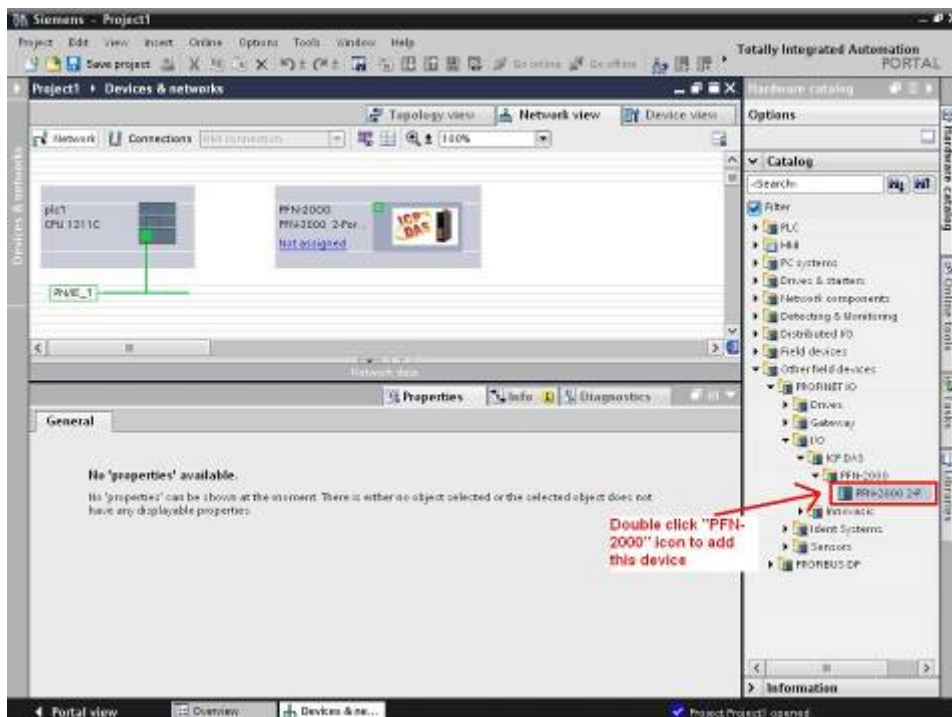

PFN-2000 User Manual (Version 1.30, Sep/2014)

Copyright © 2014 ICP DAS Co., Ltd. All Rights Reserved. E-mail: service@icpdas.com

◆ Select PROFINET interface

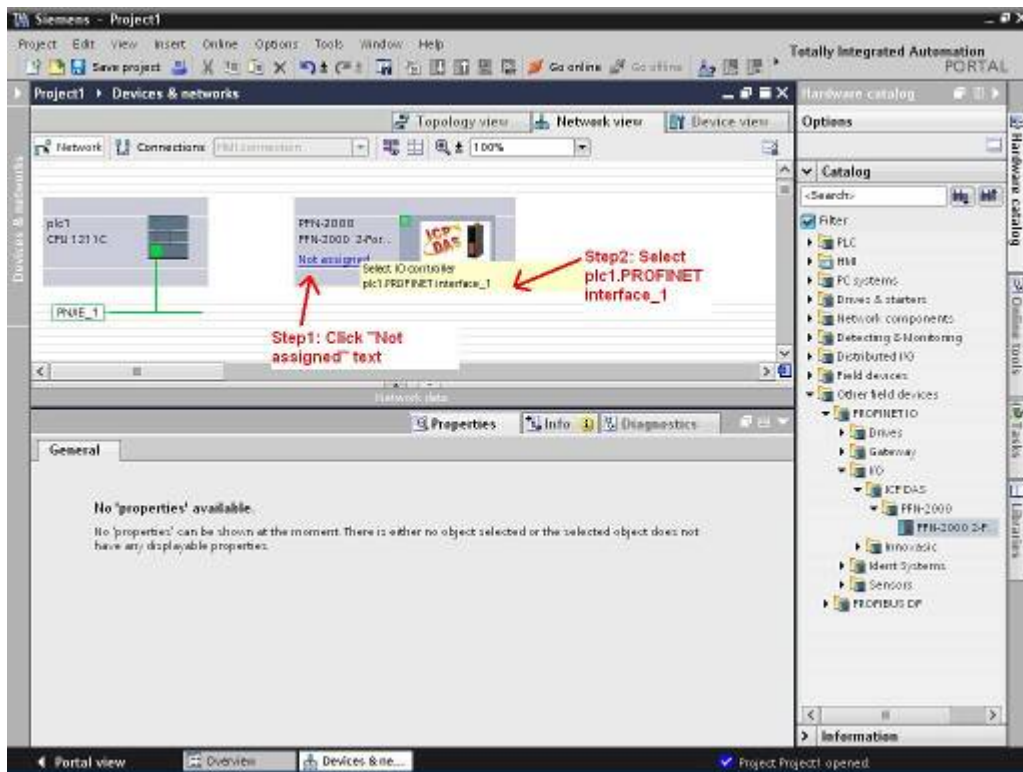

◆ Set device name to "pfn-2000"

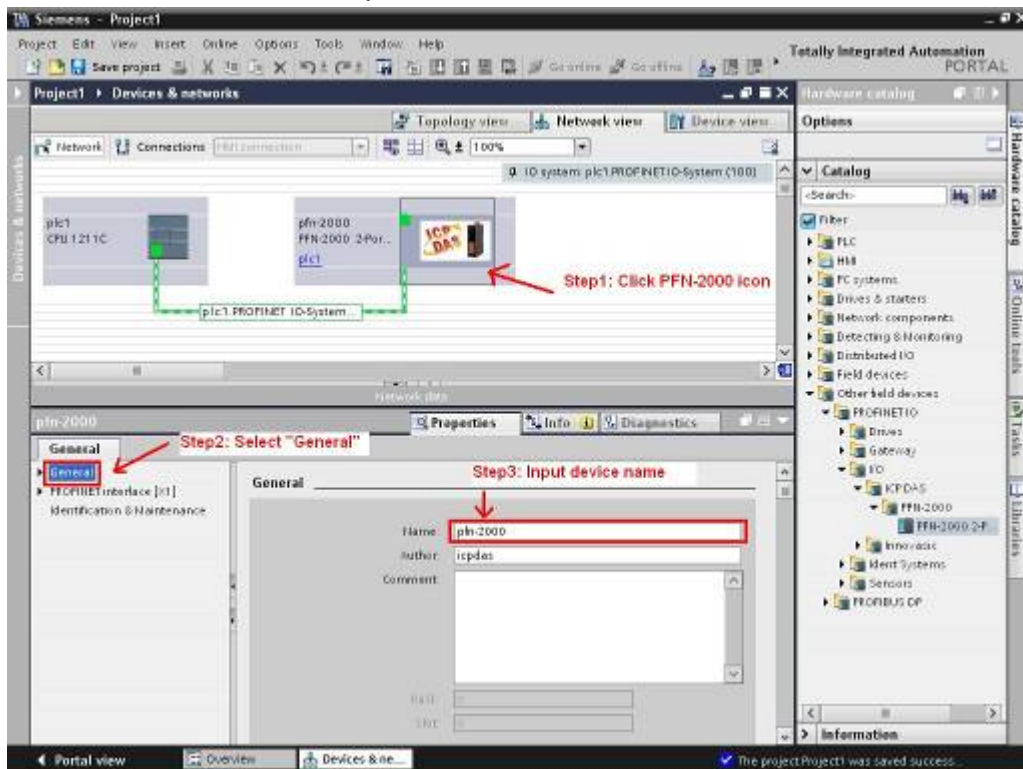

◆ Set the IP of PFN-2000 module

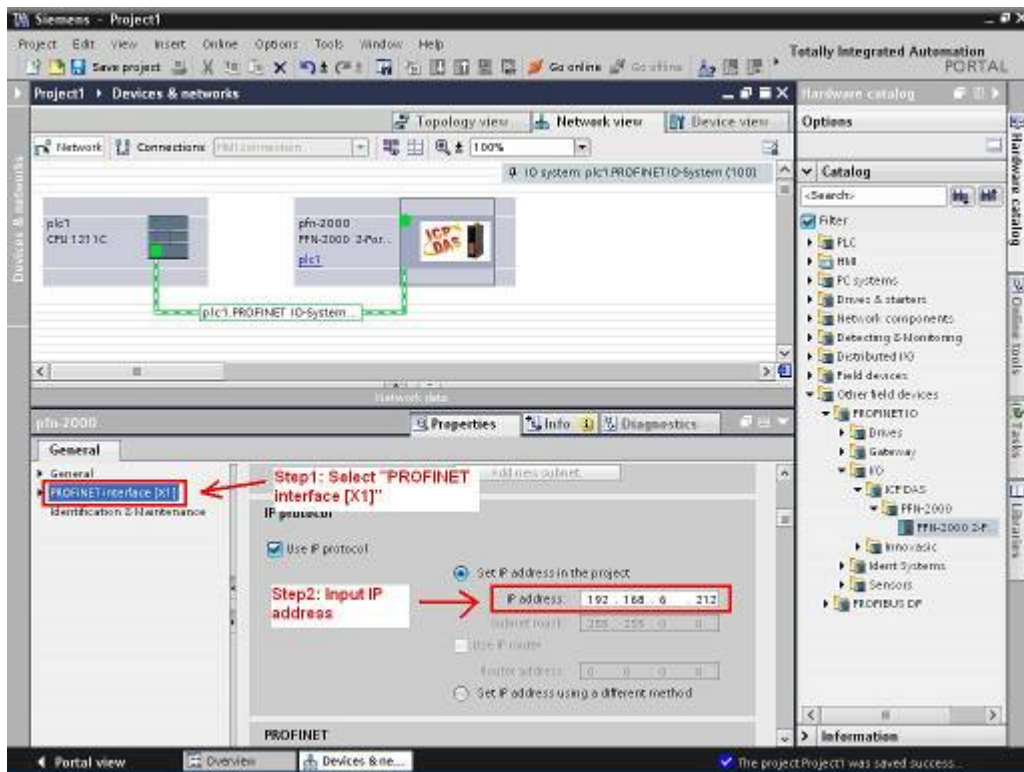

◆ Select module type of PFN-2000 module

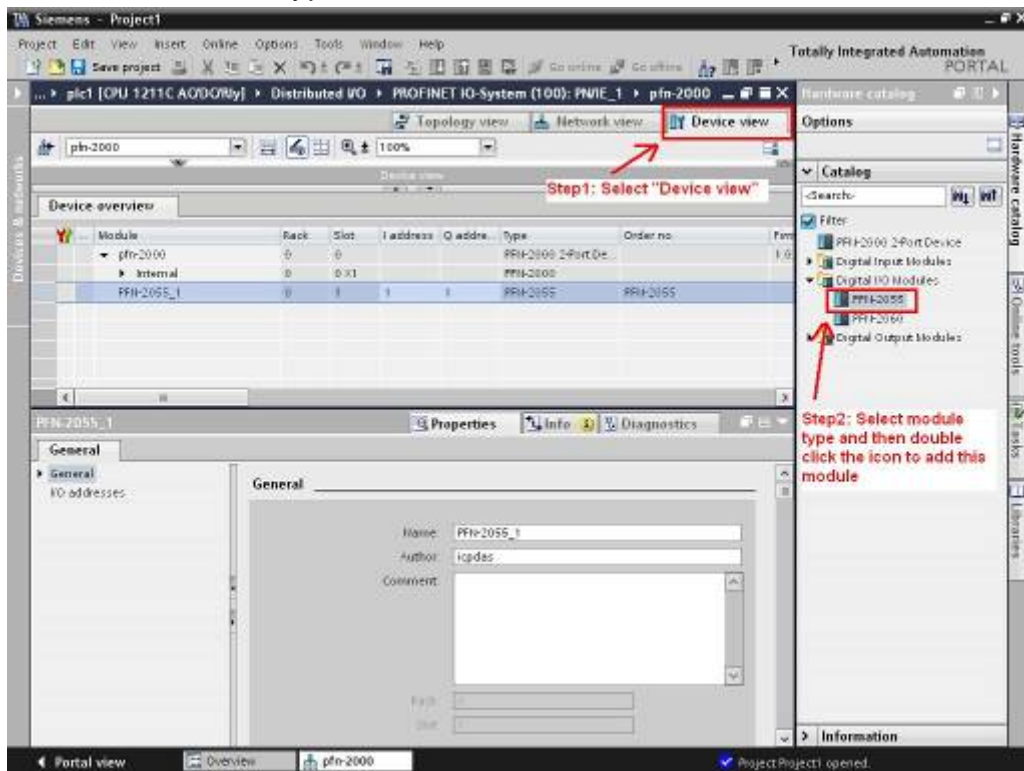

PFN-2000 User Manual (Version 1.30, Sep/2014)

Copyright © 2014 ICP DAS Co., Ltd. All Rights Reserved. E-mail: service@icpdas.com

◆ Compile and download to device

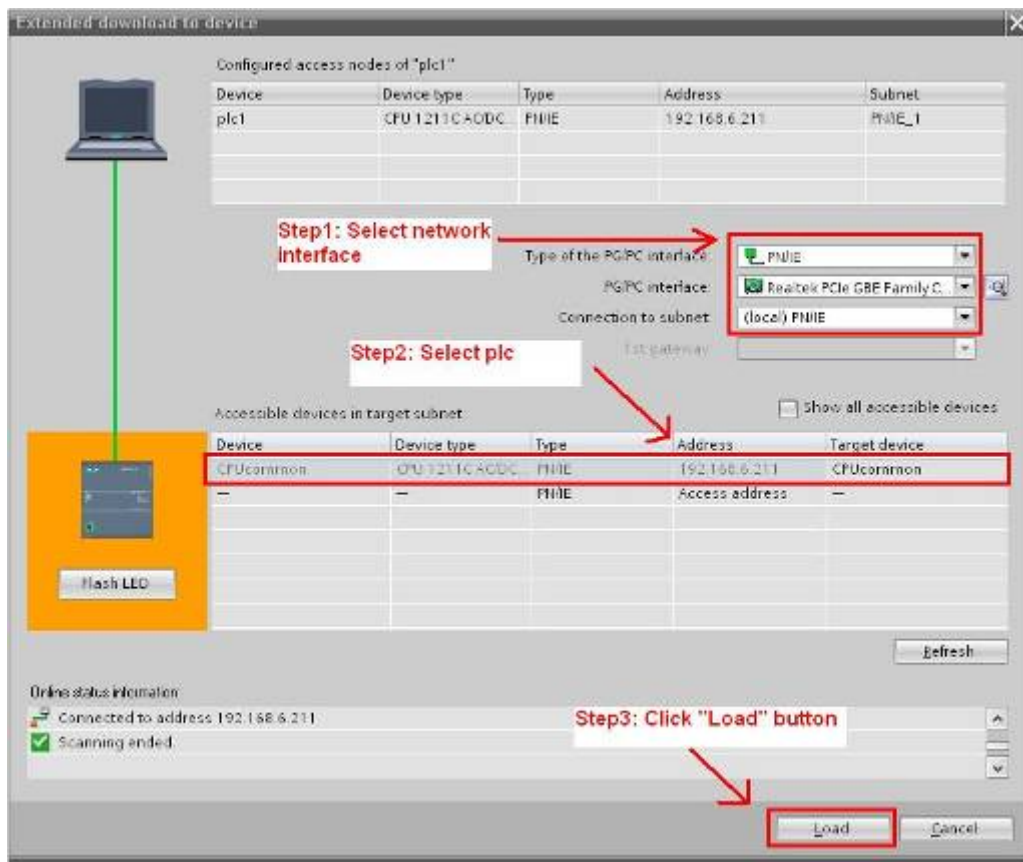
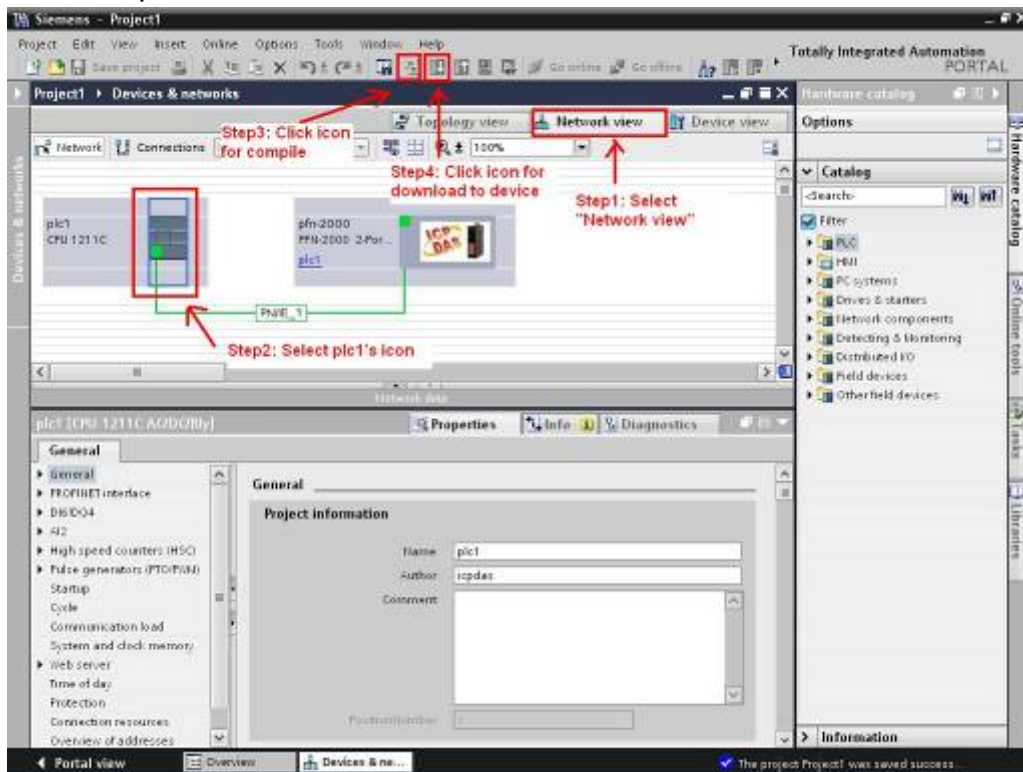

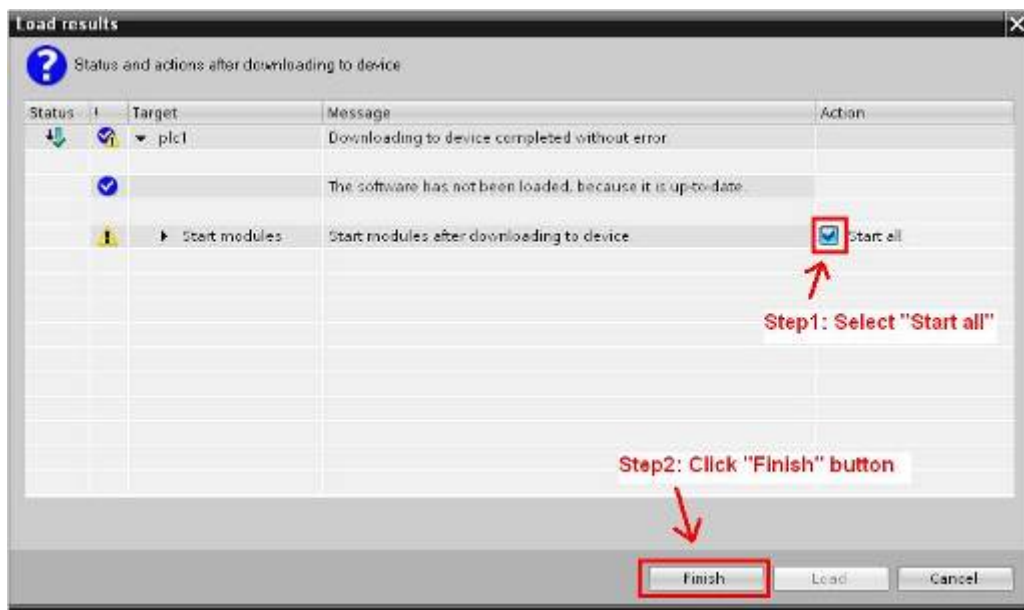
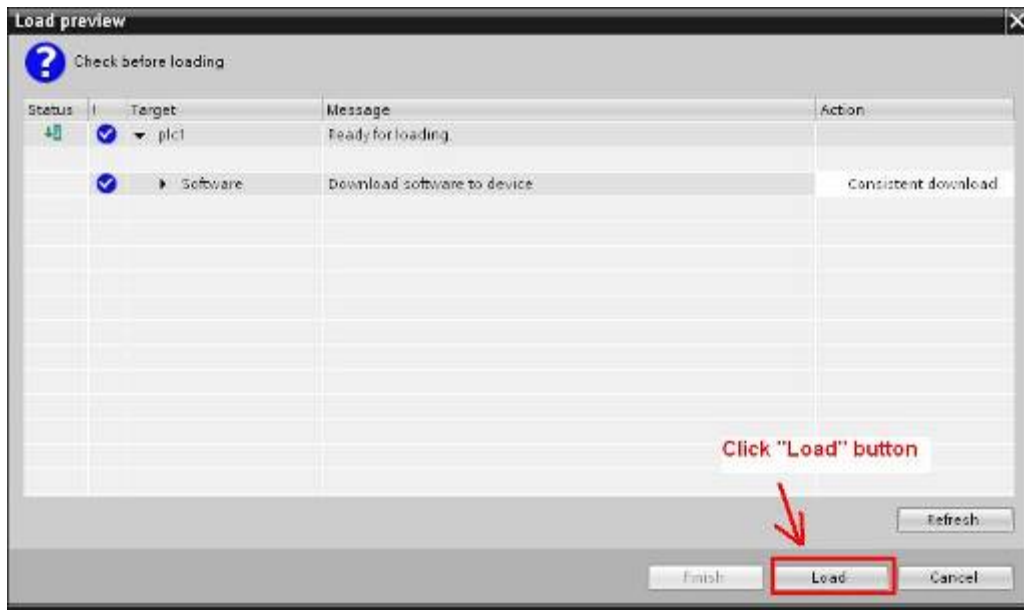

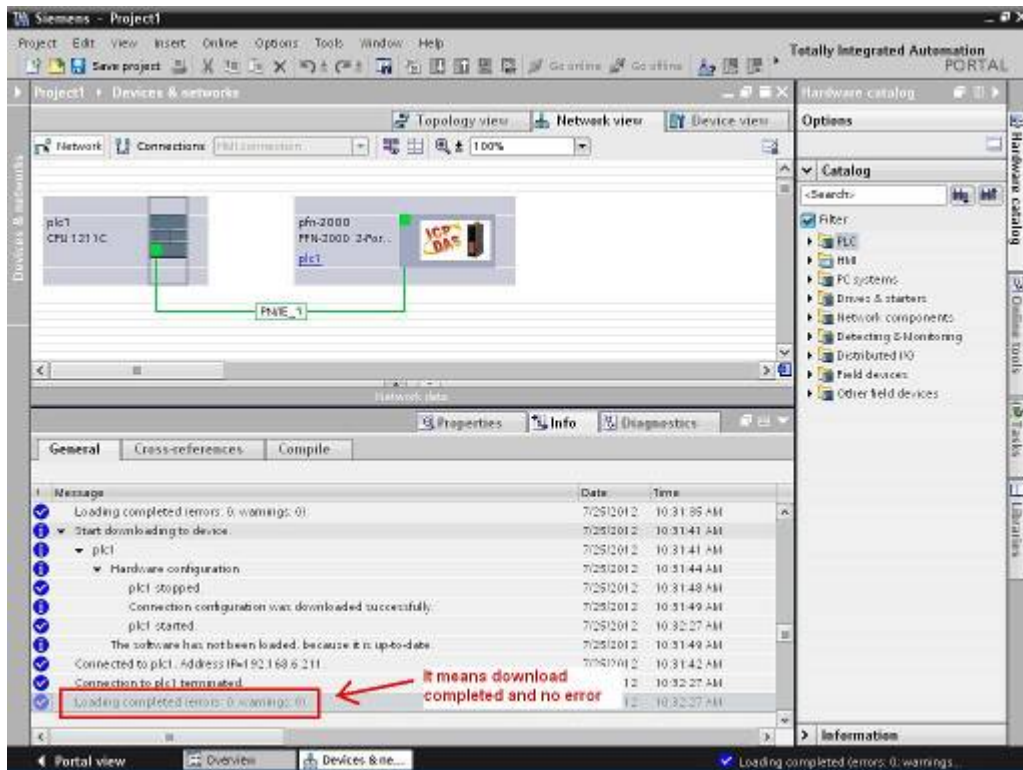

At this time, the S1A & S2A LEDs of PFN-2000 module should turn on, it means the connection between PLC and PFN-2000 module is established.

3.5. I/O Data Exchange

In this example, please follow the step to exchange data.

Step 1: Confirm data address

In this example, the pfn-2055 module address is IB1 (input data address = 1) and QB1 (output data address = 1), please refer to section 3.4 Project Setup=> Step 2: Project configuration=> Select module type of PFN-2000 module.

Step 2: Add a new watch table

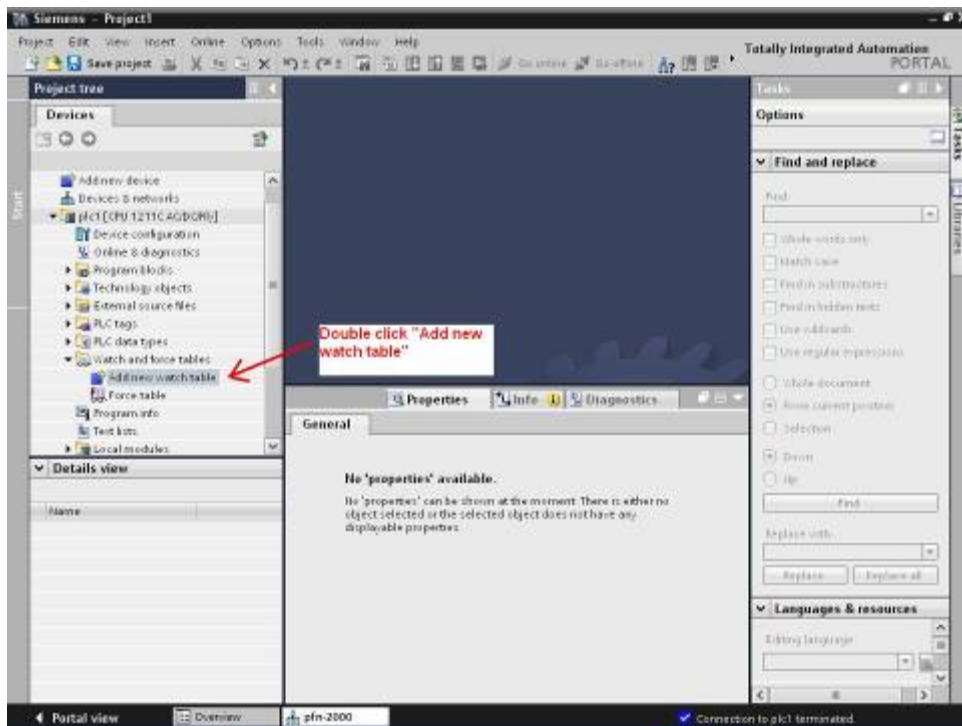

Step 2: Input IB & QB address

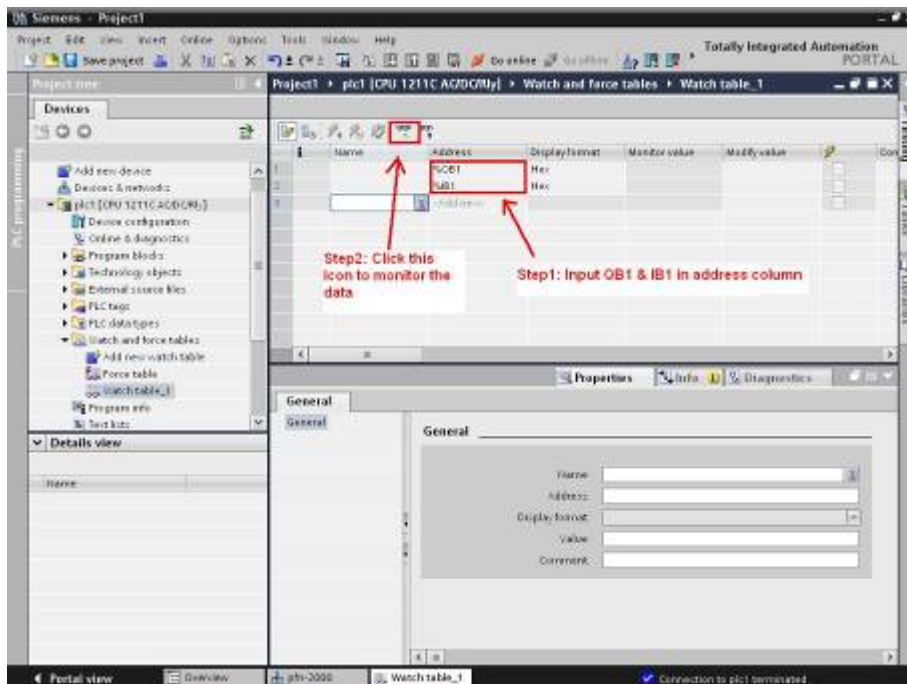

Step 3: Get input data and set output data

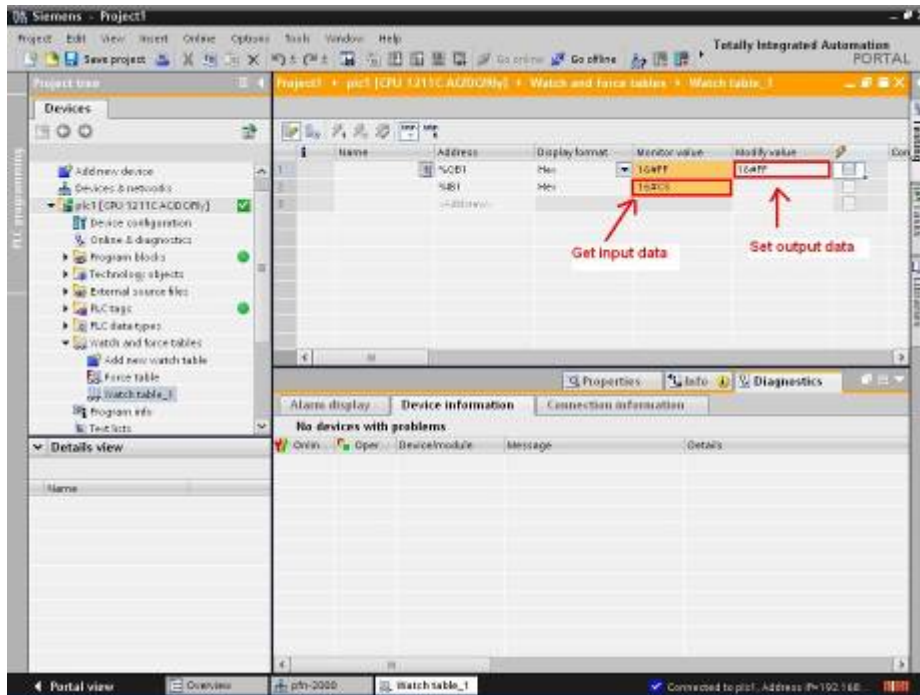

3.6. Module Parameter Settings

The user can configure the module parameters to set the I/O settings of PFN-2000 modules by the PROFINET configuration tool. The module parameters are described below.

Digital I/O module:

Module has no parameterization data.

PFN-2019 module:

- Byte Order –
 1. Big Endian (Motorola format)
 2. Little Endian (Intel format)
- Data Format –can be selected either engineer unit format or hexadecimal format.

PFN-2000 User Manual (Version 1.30, Sep/2014)

1. Engineer-Unit
 2. 2's Complement HEX
- Filter Selection – can be selected either 60Hz rejection or 50Hz rejection.
 1. 60HZ rejection
 2. 50HZ rejection
 - CJC Enable – is a flag that determines PFN-2019 whether CJC (cold junction compensation) will enable or not.
 - Wire Detection – is a flag that determines PFN-2019 whether wire detection (just for thermocouple) will enable or not.
 - Channel Enable – is a flag that determines PFN-2019 whether current channel will acquisition data or not.
 - Type Code – means the measurement type (voltage, current, temperature) and range.
 1. +/- 15mV (Code:0x00)
 2. +/- 50mV (Code:0x01)
 3. +/- 100mV (Code:0x02)
 4. +/- 500mV (Code:0x03)
 5. +/- 1.0V (Code:0x04)
 6. +/- 2.5V (Code:0x05)
 7. +/- 20mA (Code:0x06)
 8. +4~+20mA (Code:0x07)
 9. +/- 10.0V (Code:0x08)
 10. +/- 5.0V (Code:0x09)
 11. TC J-Type (Code:0x0E)
 12. TC K-Type (Code:0x0F)
 13. TC T-Type (Code:0x10)
 14. TC E-Type (Code:0x11)
 15. TC R-Type (Code:0x12)
 16. TC S-Type (Code:0x13)
 17. TC B-Type (Code:0x14)
 18. TC N-Type (Code:0x15)
 19. TC C-Type (Code:0x16)
 20. 0~+20mA (Code:0x1A)
 - CJC Offset – is used to adjust CJC.

4. MiniOS7 Utility Tool

The MiniOS7 Utility is a useful tool that provides a quick and easy way to get Ethernet settings and firmware version of PFN-2000 series modules.

4.1. Installing the MiniOS7 Utility

Step 1: Get the MiniOS7 Utility tool

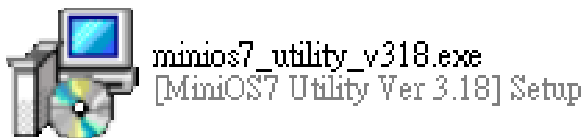

The MiniOS7 Utility can be obtained from companion CD or our FTP site:
CD:\Napdos\minios7\utility\minios7_utility\
ftp://ftp.icpdas.com/pub/cd/8000cd/napdos/minios7/utility/minios7_utility/

Step 2: Follow the prompts to complete the installation

After the installation has been completed, there will be a new short-cut for MiniOS7 Utility on the desktop.

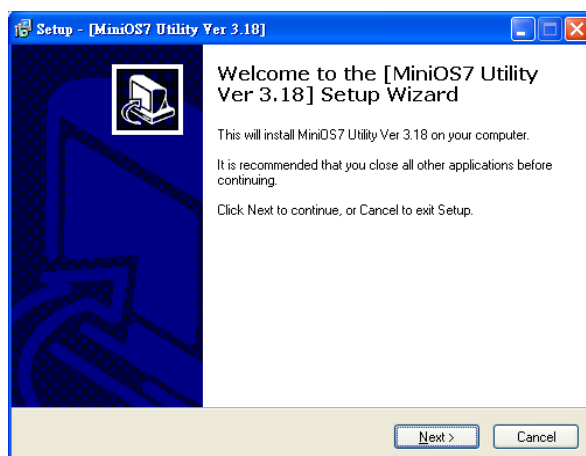

4.2. Using MiniOS7 Utility to get Ethernet settings and firmware version

Step 1: Run the MiniOS7 Utility

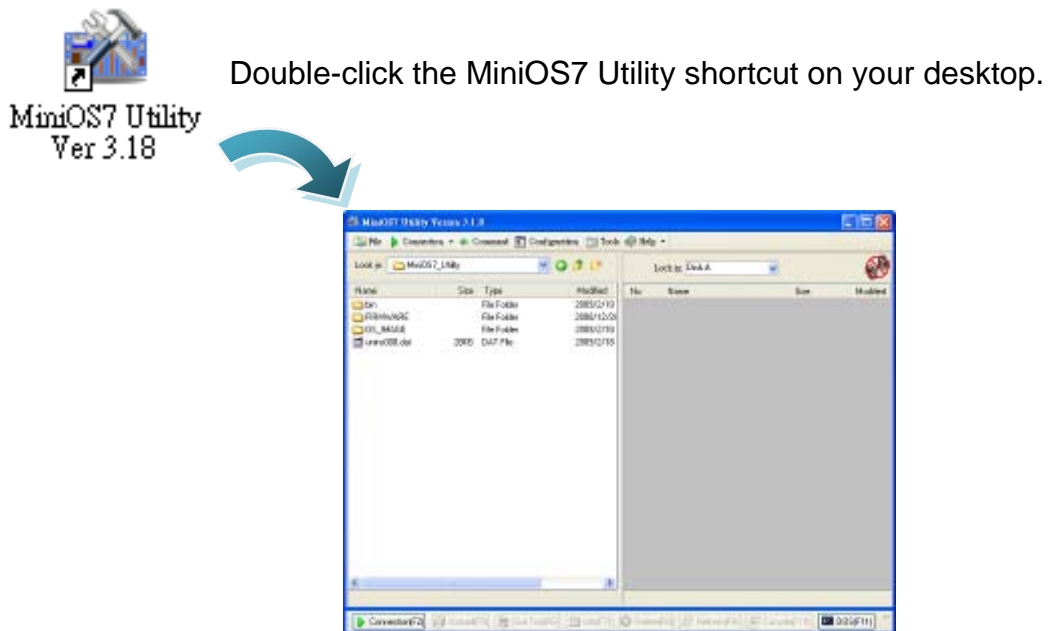

Step 2: Press “F12” or choose “Search” from the “Connection” menu

After pressing **F12** or choosing **Search** from **Connection** menu, that will search all of the modules that provide by ICP DAS on your network.

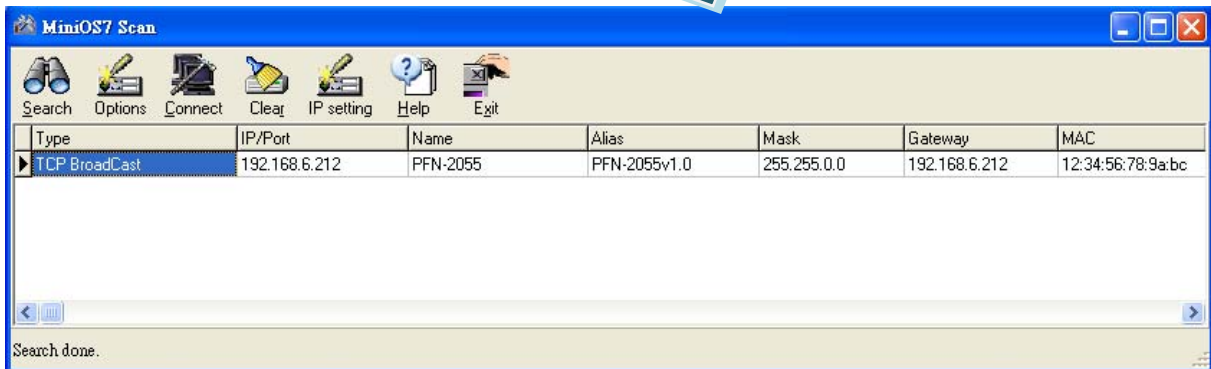
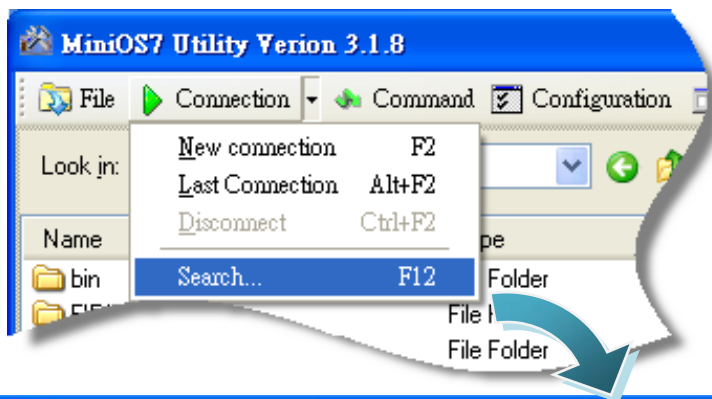

Tips & Warnings



1. If you can't find the module by searching the network. It means the IP address of PFN-200 module is zero (default IP = 0.0.0.0). At this time, please follow the section 3.2 "Network configuration=> Step 3: Set PFN-2000 module's name and IP" to set module's IP and then re-search the network again. Or, wait for the PROFINET controller connect to PFN-2000 module (S1A LED=ON & S2A LED=ON) and then re-search the network again.
2. About scan result of MiniOS7 Utility, Alias=module name & firmware version.

5. PFN_Tool Utility

5.1. Installing the PFN_Tool Utility

Step 1: Get the PFN_Tool Utility



The PFN_Tool Utility can be obtained from companion CD or our FTP site:
CD:\fieldbus_cd\profinet\utility\
ftp://ftp.icpdas.com.tw/pub/cd/fieldbus_cd/profinet/utility/

Step 2: Follow the prompts to complete the installation

After the installation has been completed, there will be a new shortcut for PFN_Tool Utility on the desktop.

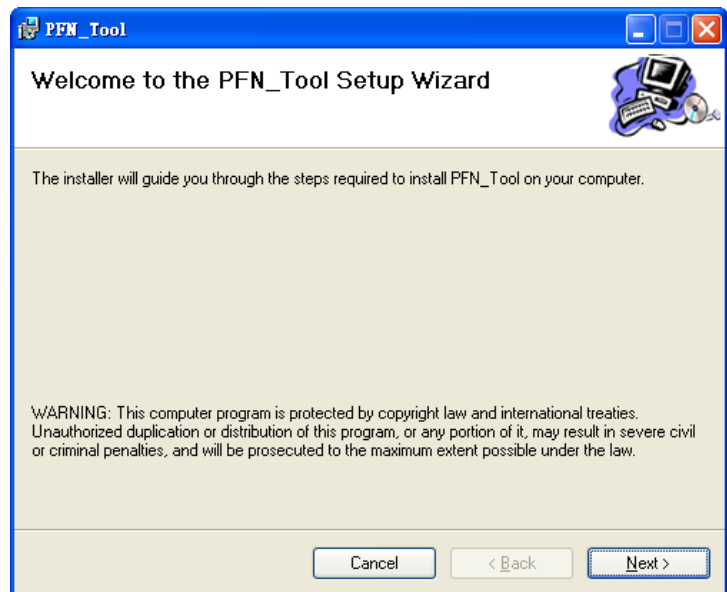

5.2. PFN_Tool Utility Functionalities

5.2.1. Module Search

Step 1: Select Network Device

Select network device that connect with PFN-2000 modules, and press “Search Start” button.

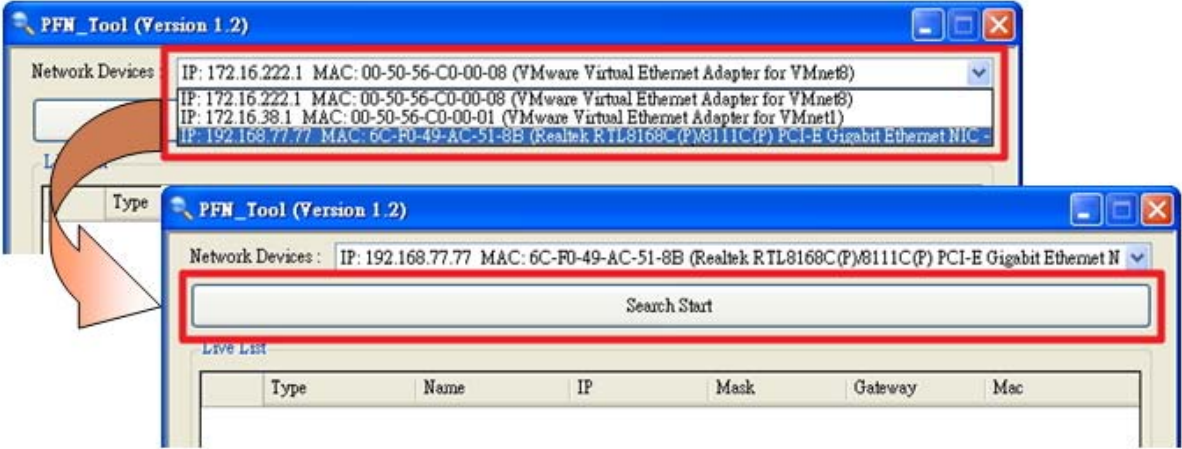

Step 2: Search results

Live List will show all of the PROFINET devices on the same network of network device.

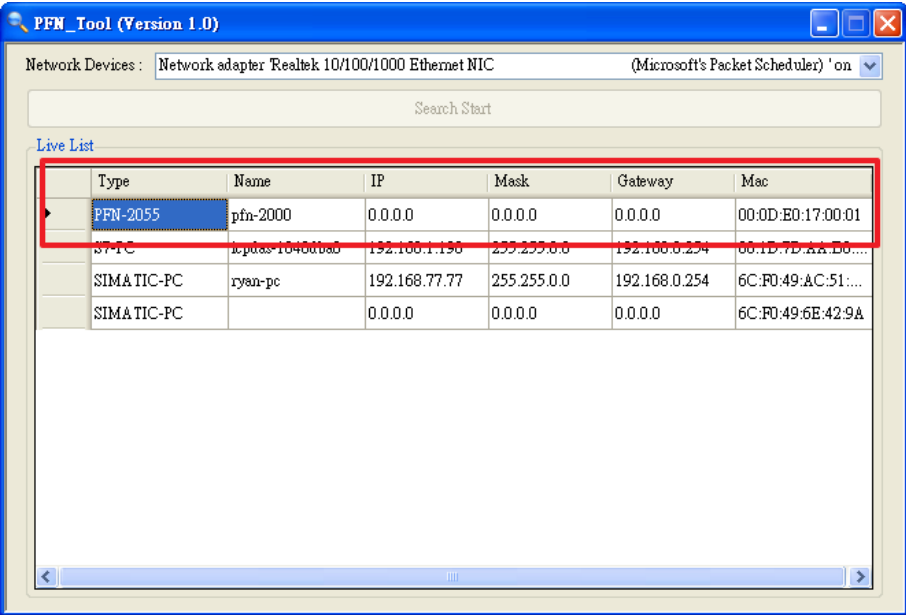

5.2.2. Module Basic Configuration

Step 1: Open Device Basic Configuration

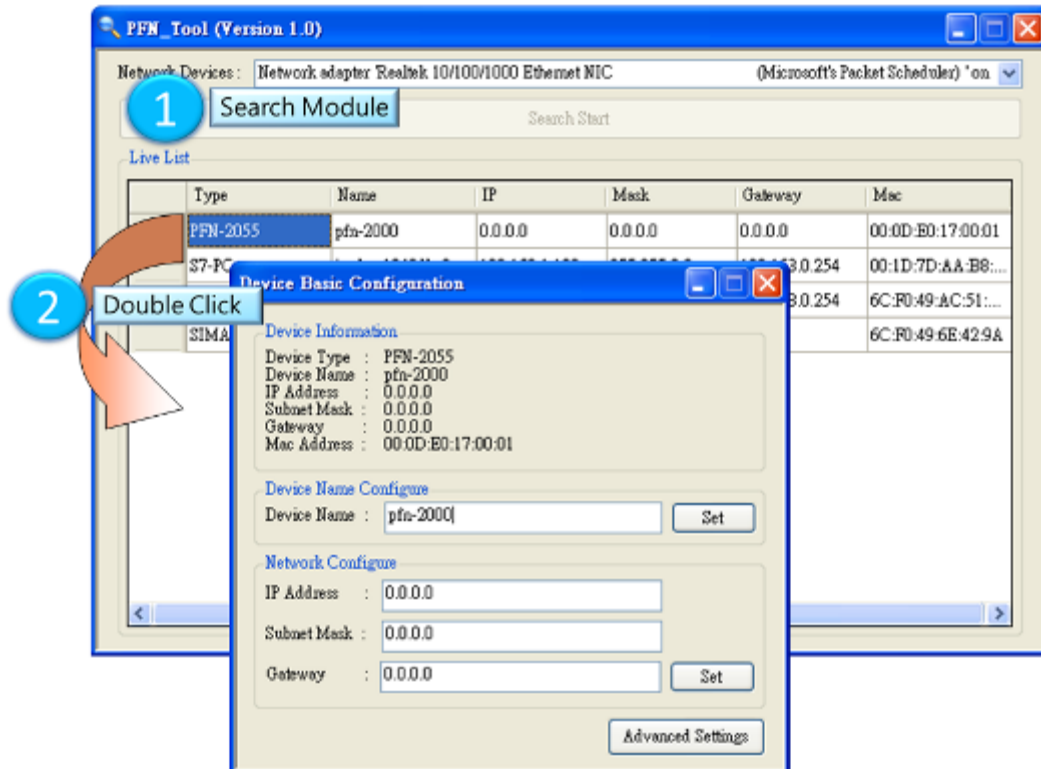

Step 2: Set Device Name

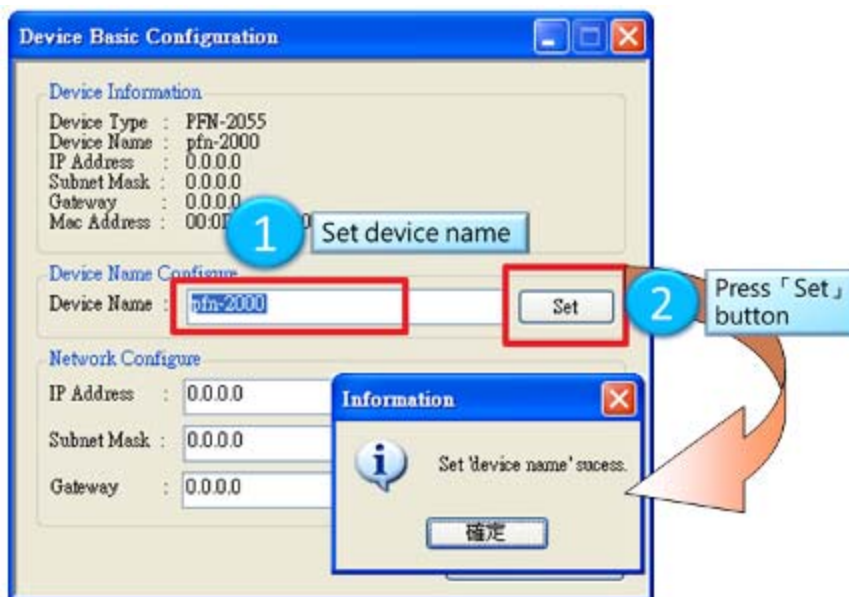

Step 3: Set Network Parameters

The network parameter of PFN-2000 module must have the same domain and different IP with PC.

EX: PC's IP = 192.168.1.110

PFN-2000 module's IP = 192.168.1.111

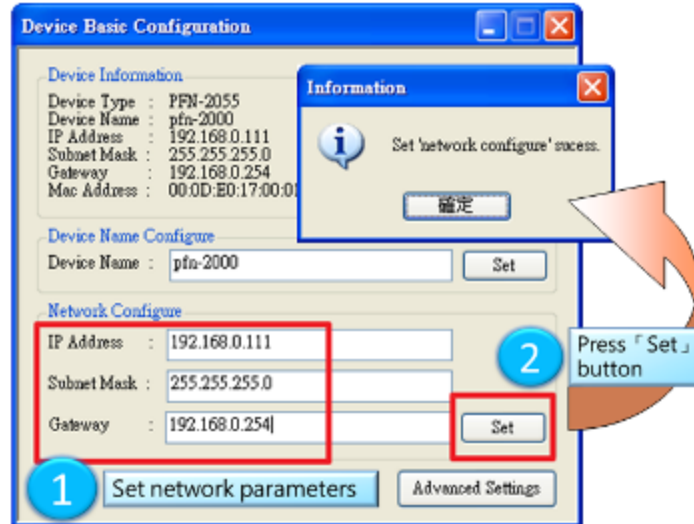

```
Connection-specific DNS Suffix . : 
Description . . . . . : Realtek RTL8168C(P)/8111C(P) PCI-E Gigabit Ethernet NIC
Physical Address. . . . . : 6C-F0-49-AC-51-8B
Dhcp Enabled. . . . . : No
IP Address. . . . . : 192.168.0.110
Subnet Mask . . . . . : 255.255.255.0
Default Gateway . . . . . : 192.168.0.254
DNS Servers . . . . . : 168.95.1.1
```

Tips & Warnings



1. When PROFINET controller connect to PFN-2000 module (S1A LED=ON & S2A LED=ON), user can't set device name and network parameters.



5.2.3. Module Advanced Configuration

Step 1: Open Device Advanced Configuration

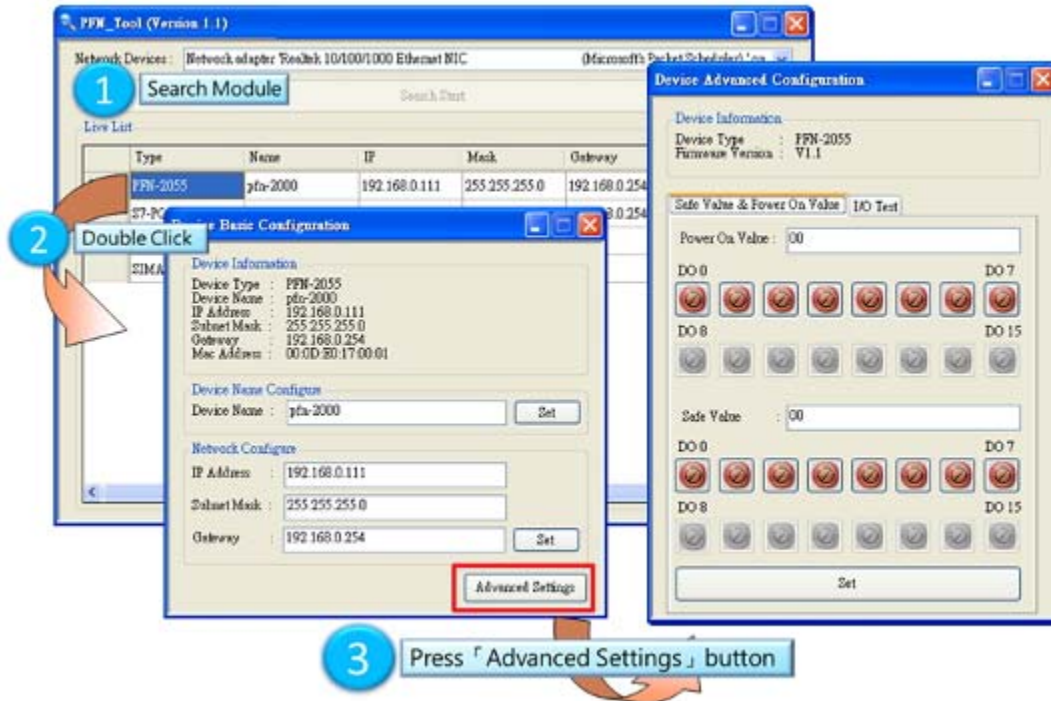

Step 2: Set Device Information On Value and Safe Value

User can set Power On Value and Safe Value in the field, or set by channel button.

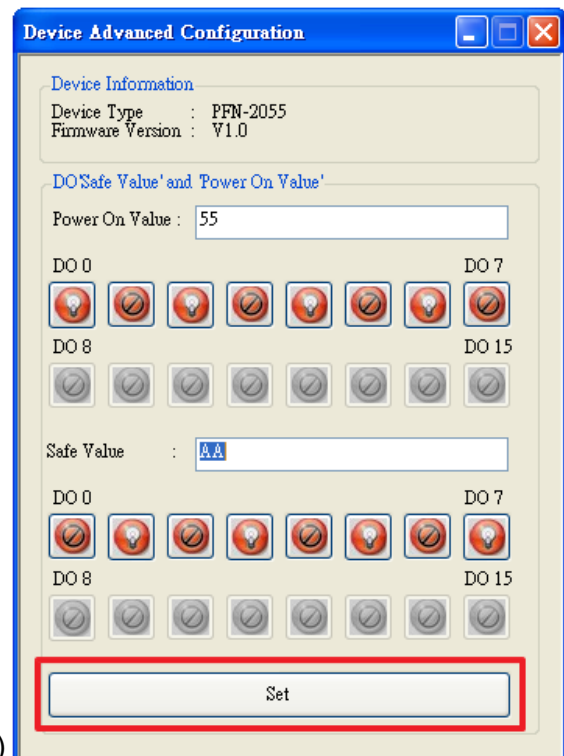
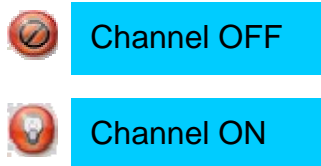

PFM-2000 User Manual (Version 1.30, Sep/2014)

Tips & Warnings



1. When rotary switch set to “6”, Power On Value and Safe Value set in “Device Advanced Configuration” will be used.

Step 3: I/O test

User can use I/O test function to test DO state and DI state.

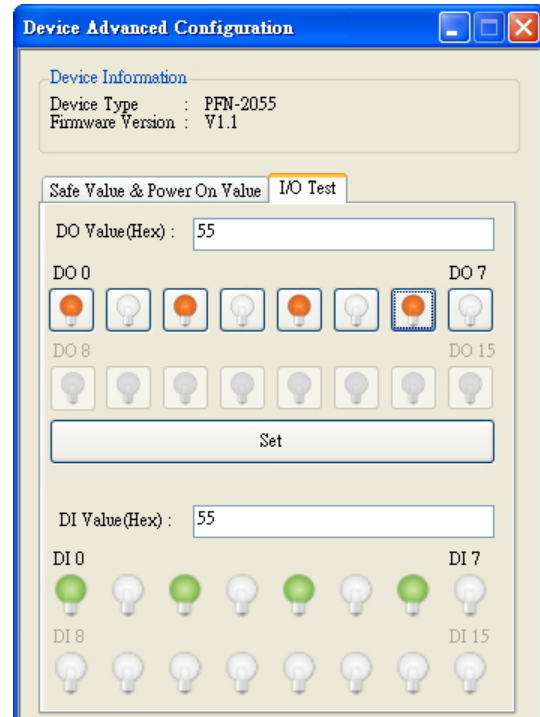

Tips & Warnings



1. When PROFINET controller connect to PFN-2000 module (S1A LED=ON & S2A LED=ON), user can't change DO state.

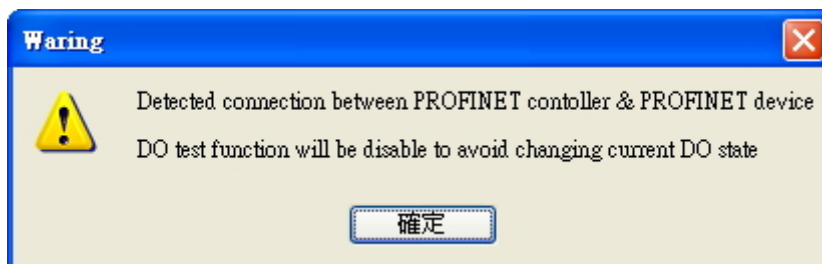

6. Troubleshooting

Item	Trouble state	Solution
1	'PWR' LED is always off.	The power supply of PFN-2000 module has some problems. Please check the wire connection of the power and the voltage is between 10~30V _{DC} .
2	'S2B' LED is always flash and 'S1A' LED is always on.	That means the PFN-2000 module can't connect to the PROFINET IO controller. Please check the wire connection and module configuration (include network settings, device name) and project configuration of engineering tool that provide by PROFINET IO controller's manufacturer.
3	'S1B' LED is always flash and 'S1A' LED is always on.	It means the PFN-2000 module is received the error parameter. Please check the project configuration of engineering tool that provide by PROFINET IO controller's manufacturer. The type of pfn-2000's submodule may be not the same with the field device in the project.
4	'S1B' LED is always on.	It means the PFN-2000 module is at Bootloader mode. Please set the PFN-2000 module to Run mode.
5	Can't find any PFN-2000 module by MiniOS7 Utility	It means the IP address of PFN-2000 module is zero (default IP = 0.0.0.0). At this time, please follow the section 3.2. "Network configuration=> Step 3: Set PFN-2000 module's name and IP" or section 5.2.2 "Module Basic Configuration" to set module's IP and then re-search the network again. Or, wait for the PROFINET controller connect to PFN-2000 module (S1A LED = ON & S2A LED = ON) and then re-search the network again.
6	Can't find any PFN-2000 module by PFN_Tool Utility	<ol style="list-style-type: none"> Please check the wire connection Please set the PFN-2000 module to Run mode, please refer to the section 1.6.2→Rotary Switch. Please check network card is ok, and PFN-2000 module and network card have to in the same network. Please open the file"configure.ini" (C:\Program Files\ICPDAS\PROFINET\PFN_Tool). In this file, please set Static_Mac=Enable & Mac_Addr= MAC address of network device.