

Your Automation Site !

Industrial and  
embedded control,  
data acquisition,  
logging and avionics

**I/O**



- Ethernet Data Acquisition and Control
- Embedded Controllers
- Distributed I/O
- Dataloggers
- Simulink I/O Targets
- Avionics Interfaces



**10** 10-YEAR  
AVAILABILITY  
GUARANTEE



**Your Automation Site !**

# Featured Products



## UEI Net

Provides the power of a GigE Cube with a single DNA-series board in a ultra-compact footprint.



## DNR-MIL

All the benefits and performance of our DNR series RACKtangle platform but with 38999 style connectors and a MIL Rated IP65 sealed enclosure.



## New I/O Boards [Pages 33-46]

See the latest I/O Boards for both RACK and Cube Chassis.

# Table of Contents:

## Introduction

General intro to the product line .....	2
Understanding the form factors .....	3
Hosted or Stand-Alone Deployment options .....	4
Software options and compatibility guide .....	5

## PowerDNA Cube/RACK/FLATRACK: I/O Chassis

Introduction and Advantages .....	6-8
Applications and Setup Software .....	9
Specifications .....	11

## UEIPAC: Programmable Automation Controller

Introduction .....	12
Programming .....	13
Specifications .....	14
Features, Applications and Ordering Guide .....	15

## UEILogger: Stand Alone Data Logger/Recorder

Features and General Description .....	16
Specifications and Ordering Guide .....	17

## UEISIM: Simulink/Coder I/O Target

Introduction .....	18
Programming and Ordering Guide .....	19
Specifications .....	20

## UEIModbus: Modbus TCP I/O

General Description .....	21
---------------------------	----

## UEIOPC-UA: OPC Unified Architecture /O

General Description .....	21
---------------------------	----

## UEI Net: Ultra Compact I/O system

General Description .....	22-25
---------------------------	-------

## MIL Series: Military ready I/O systems

General Description .....	26-28
---------------------------	-------

## Cube and RACKtangle Chassis Detail

DNA Series PPC and GigE Cube Detail .....	29
DNR Series RACKtangle and HalfRACK Detail .....	30-31
DNF Series FLATRACK Detail .....	32

## I/O Boards for RACKtangle and Cube Chassis

I/O Overview .....	33
Analog Input .....	33-35
LVDT/RVDT/Synchro/Resolver .....	35
Analog Output .....	36-37
Digital I/O .....	38-40
RS-232/422/485 .....	40
HDLC/SDLC Synchronous Serial .....	40
CAN-Bus .....	40
Avionics (ARINC-429/453/708, MIL-1553, AFDX®) .....	41
Counter/Quadrature I/O .....	41-42
IRIG-A/B/E/G and GPS .....	42
WiFi / Cell Network for the UEIPAC .....	42

## I/O Quick Reference Guide & MTBF Specifications

I/O board quick reference table with MTBF specs .....	43-46
---	-------

## Accessories for RACKtangle and Cube Chassis

Cables, Screw Terminal Panels, etc. ....	47-48
--	-------

## PCI/PDXI Bus Data Acquisition and Control Boards

A/D and Multifunction Boards .....	49
Analog Output and Digital I/O Boards .....	49

## FAQs .....

.....	50-51
-------	-------

## App Notes and White Papers .....

.....	51
-------	----

## Typical Applications .....

.....	52-57
-------	-------

# The Four Dimensions of your UEI System.

## Form Factor

UEI offers a wide variety of different chassis styles. The electronics in all of these is identical COTS technology. This is an often misunderstood concept so it is worth stating again:

**Whether you choose a Cube, RACKTangle, FLATRACK, UEINet or MIL chassis, the internal electronics, software support and compatible I/O boards are identical.**

- The 3U RACKTangles are easily mounted in standard 19" racks or against any bulkhead.
- The 1U FLATRACK allows up to 4 I/O boards to be installed in an AC or DC powered 1U chassis.
- Cubes are compact and rugged. They are available in low power 100Base-T or standard GigE formats.
- The MIL series RACKs and Cubes are ideal for military or ruggedized commercial applications with all connections through standard military 38999 connectors.
- The UEINet is a new single I/O slot chassis that fits an entire I/O system in an ultra compact 2.7" x 4" x 4" chassis.

For more info on the various form factors please refer to the overview on page 3 or see the detailed information contained later in this catalog.

## Operating System and Programming Options

Though most customers consider UEI a "hardware" company, we never underestimate the value of software in our products. We know that none of our hardware is of any value whatsoever without software. In fact, in both our design team and support team, we have more software engineers than hardware.

Our goal is to provide you with the software support you desire, regardless of what programming language, application or operating system you wish to use.

Almost everyone in the industry has good Windows support and UEI is no exception. You'll find our support, including our UEIDAQ Framework is the most robust, simplest to use interface available. Whether you're programming in C, VB, any of the .NET languages or application such as LabVIEW and MATLAB our support is unequalled.

However, where UEI really differentiates itself is in the support of Linux, VxWorks, QNX, RTX, INTime and languages outside the Windows world. We never leave our customers looking to bulletin boards or open source for drivers. Everything is written and fully tested by our software team.

For more info on the software support available on our various hardware platforms, please refer to page 5.

## Hosted versus Standalone Deployment options

Depending on your application, you may wish to have the UEI I/O hardware controlled by a host PC, run standalone DAQ/control applications, or work in a SCADA configuration.

The hardware (chassis and I/O boards) are identical in each of these deployment options. Only the firmware and the software is different. As with the Form Factor discussion, this is an often missed point and is worth stating again:

**The chassis/electronics for each of the deployment options described below is identical. Only the firmware/software differentiates the functionality of the various options.**

### UEI chassis slaved to a host PC over Ethernet

We refer to this as PowerDNA mode.

### Standalone Linux or VxWorks based embedded system

This deployment option is known as the UEIPAC.

### Standalone datalogger with no programming required

This deployment option is the UEILogger.

### Simulink target

This option is referred to as the UEISIM.

### Modbus TCP I/O system

This option is referred to as the UEIModbus.

### OPC-UA compatible, embedded I/O system

This option is referred to as the UEIOPC-UA

More details on these options are on page 4.

## I/O Board Selection

With well over 60 different I/O boards available, UEI is sure to have just what your application needs. We understand that connecting to 98% of the signals in your system is simply not enough. Our goal is to have 100% of what you need. Beyond that, our goal is also to connect directly to what your system provides without the need for external signal conditioning. Our product line includes:

- Analog inputs (VIn, IIn, TCs, RTDs, Strain, ICP/IEPE etc.)
- Analog outputs (Vout to 115VDC, 4-20 mA, etc.)
- Logic level DIO
- Industrial and high voltage DIO
- Counters, Timers, IRIG timing
- Avionics (ARINC 429/708/453, MIL-1553, AFDX etc.)
- Serial Communications (Async and Synchronous)
- RVDT/LVDT/Synchro/Resolver (input and simulated out)
- Quadrature encoder input
- Variable Reluctance input
- CAN-bus input (including J-1939 and .DBC)
- WIFI and GSM wireless interfaces
- Function generator outputs

For more info on our extensive line of I/O boards, please see pages 33-46. Note that all of our I/O boards are compatible with our entire line of chassis!

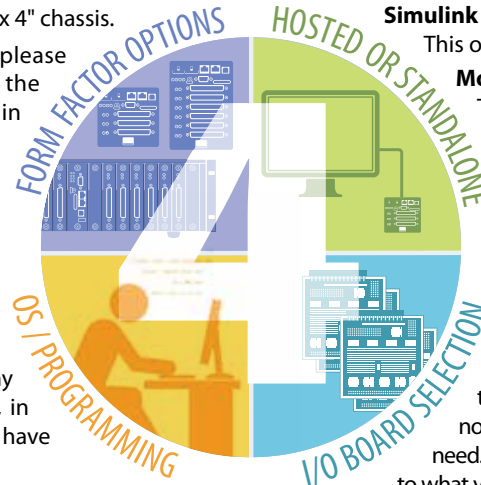

## RACKtangles



- Standard 3U, 19" rack form factor
- Front slot loading for quick repair and replacement
- Rugged: up to 3g Vib, 100g Shock, -40 to +70°C
- 19" rack or bulkhead mounting options
- 6 slot and 12 slot versions available
- Supports PDNA, UEIPAC, UEISIM and UEIModbus and UEIOPC-UA deployments

## FLATRACKS



- Standard 1U, 19" rack form factor
- Dual Ethernet ports
- Rugged: up to 3g Vib, 100g Shock, -40 to +70°C
- AC or DC power
- 4 I/O slots
- Supports PDNA, UEIPAC, UEISIM and UEIModbus and UEIOPC-UA deployments

## Cubes



- Compact: 4" x 4" x 4" for 3 I/O slot version  
4" x 4" x 6" for 6 I/O slot version
- Rugged: up to 5g Vib, 100g Shock, -40 to +85°C
- Flange or DIN rail mounting options
- Fiber Ethernet option
- Supports PDNA, UEIPAC, UEISIM and UEIModbus and UEIOPC-UA deployments

## UEINet



- Ultra Compact: 2.7" x 4" x 4"
- Rugged: up to 5g Vib, 100g Shock, -40 to +70°C
- Flange or DIN rail mounting options
- Supports PDNA, UEIPAC, UEISIM and UEIModbus and UEIOPC-UA deployments

## MIL series



- Ultra rugged and robust: Designed to meet MIL-STD-461/810/704/1275.
- Rugged: up to 5g Vib, 100g Shock, -40 to +70°C
- 4U RACK or bulkhead mounting options
- All connections through 38999 connectors
- Supports PDNA, UEIPAC, UEISIM and UEIModbus and UEIOPC-UA deployments

# Six Deployment and Usage Options



**Tethered / Slaved to Host PC over Ethernet**  
application runs on host

**Stand-alone / Embedded I/O**  
Linux or VxWorks application runs on Cube/RACKtangle

**Stand-alone Data Logger**  
application created on PC, runs stand-alone on Cube

**Simulink / HIL**  
application created in Simulink runs on Cube/RACKtangle

**Modbus TCP I/O**  
application runs on host PC

**OPC-UA Embedded I/O**  
application runs on network

1 **PowerDNA** — Page 6

2 **UEIPAC** — Page 12

3 **UEILogger** — Page 16

4 **UEISIM** — Page 18

5 **UEIModbus** — Page 21

6 **UEIOPC-UA** — Page 21

## Six System Configurations:

UEI's Cube and RACKtangle systems may be deployed in a wide variety of configurations. They will function as I/O slaves under control of a host PC, may be run as fully stand-alone data loggers or embedded controllers, or can be run as a hybrid, running applications locally, but taking direction from, or sharing data with a host PC on the network.

**PowerDNA:** Our PowerDNA series chassis act as I/O slaves to a host PC. They perform the tasks the host commands. This configuration works well in both data acquisition and control applications. PowerDNA mode, supports all popular operating systems including Windows,® Linux®, QNX,® VxWorks® and more. We also support all popular application software including MATLAB®, LabVIEW™, DASYLab® and more.

**UEIPAC:** When a small, stand-alone embedded controller or data logger is required, the UEIPAC is the ideal solution. Programmed in a standard Linux VxWorks operating system, the UEIPAC provides remarkable performance, flexibility and power all in a compact package. Build your application on a Linux PC, or a Windows PC using Cygwin. Once developed, compile your code and download it to the UEIPAC. From there it runs fully stand-alone, and/or you may keep the UEIPAC on your network to provide updates to your host. The UEIPAC is also frequently used as a local control node tied to a host PC. In this mode, the UEIPAC executes the local applications as directed by the host.

**UEILogger:** Applications that require only data logging are easily accomplished with our UEILogger without programming. This configuration provides one of the most compact, rugged, and high performance data loggers available. Create your application on a high-level, intuitive GUI tool which we provide for Windows platforms. Once your logging application is created, you download it to the UEILogger, disconnect it from your PC and are free to place it in location. After the data is acquired, you either reconnect to your PC via Ethernet, or simply remove the SD card and read the data directly.

**UEISIM:** The UEISIM is runs your Simulink models on real I/O. First you build a standard Simulink application. Next you generate code using Mathworks' Embedded Coder—previously known as Real-Time Workshop (RTW). Then you compile the code with the UEIPAC/SIM as the target. You can run your models stand-alone or under supervisory control of the host PC.

**UEIModbus:** If you're looking for a small, rugged I/O system to run from your Modbus TCP host PC, a Cube, or RACKtangle or FLATRACK I/O system is the perfect solution. The UEIModbus is compatible with all popular Modbus host applications and software.

**UEIOPC-UA:** If you're looking for a small, rugged I/O system to run as an OPC-UA server, the UEIOPC-UA is an ideal solution .

# Software options



## Software Quick Reference

Operating Systems	PowerDNA	UEIPAC	UEISIM	UEILogger	UEIModbus
Windows (XP and later)	✓	*	#	+	§
Linux	✓	✓	✓	+	§
VxWorks	✓	✓		+	§
QNX	✓			+	§
RTX	✓			+	§
InTime	✓			+	§

\* The UEIPAC can be programmed by Windows or Linux PCs, but the OS running on the UEI chassis is either Linux or VxWorks.

# The UEISIM can be programmed/used by Windows PCs, but the OS on the UEI chassis is Linux.

+ When not actively operating in logging mode, the UEILogger will function as a standard PowerDNA Cube.

§ The UEIModbus is supported by almost all OSs as part of generally available Modbus TCP support.

Programming Language	PowerDNA	UEIPAC	UEISIM	UEILogger	UEIModbus
C/C++	✓	✓		+	§
C#, C++/CLI, Jscript.NET	✓			+	§
Java	*			+	§
Visual Basic	✓			+	§
VB.NET	✓			+	§
Simulink			✓		

\*Not all API modes are supported

+ When not actively operating in logging mode, the UEILogger will function as a standard PowerDNA Cube.

§ There are third party and/or open source Modbus libraries available for these languages

Programming Application	PowerDNA	UEIPAC	UEISIM	UEILogger	UEIModbus	UEIOPC-UA
LabVIEW	✓			+	✓	✓
LabWindows	✓			+		
MATLAB	✓			+		
Simulink			✓			
DASYLab	✓			+	✓	
Keysight VEE	✓			+		
OPC	✓			+		
OPC-UA						✓
Excel	✓			+		
EPICS	✓	✓		+		
ActiveX	✓			+		
Modbus TCP	✓			+	✓	
SCADA Packages				+	✓	✓

+ When not actively operating in logging mode, the UEILogger will function as a standard PowerDNA Cube.

# PowerDNx Cubes and RACKs

## Ethernet DAQ and Control I/O Chassis:

- Over 60 I/O boards available
- Gigabit, 100Base-T and 100Base-FX standard Ethernet interfaces. (GigE Cube chassis have dual Ethernet ports selectable as separate control/diagnostic ports or teamed/bonded as a redundant network interface.)
- Inter-Cube sync interface
- Rugged and compact
- Powerful built-in diagnostics
- Real-time: 1000 I/O scans in < 250 microseconds
- Complete Windows and Linux support
- RTOS support including QNX, VxWorks, RTX and more
- LabVIEW™, MATLAB®, DASyLab™ support and more
- Ideal replacement for hard-to-maintain VME (with or without Reflective Memory) systems
- 10-Year Availability GUARANTEED!

## General Description:

The PowerDNA (Distributed Networked Automation) Cube, DNR RACKtangles and DNF FLATRACKS and MIL series and UEINet chassis are compact, rugged, Ethernet-based data acquisition and control chassis. Programs and applications running on a host PC receive data from input (or I/O) boards within the chassis and write data to output channels. I/O boards may be installed in any combination, allowing the Cubes/RACKs to be precisely matched to your system requirements. With over 60 different I/O boards available, there is sure to be a perfect solution for your application. DNA series Cubes and DNR/DNF series RACKS are ideally suited for a wide variety of simulation, industrial, aerospace, and laboratory DAQ and control applications.

Selecting between Cube or RACK chassis is often based as much on personal preference as actual application requirements. Their capabilities are very similar, though there are some differences that may make one or the other clearly more appropriate. Before describing the differences, it is important to point out that the three form factors are identical electronically from a user software point of view. The selection of Cube versus RACKtangle is typically based on mechanical, and ease of maintenance issues.

### PowerDNA Cubes and UEINet chassis

DNA series Cubes and UEINet chassis are smaller, and more rugged than the various RACK alternatives. The Cube and UEINet are also an ideal OEM form factor as it is easy to embed them inside your product. The standard 100Base-T Cubes are also somewhat more rugged than the RACKs and are rated from -40 °C to +85 °C, at 5 g vibration and up to 100 g shock. Special versions have even been tested to altitudes of greater than 120,000 feet. The GigE cubes and DNR and DNF series RACK chassis are rated from -40 °C to +70 °C, 3 g vibration and 100 g shock.

Cubes are developed with horizontally installed boards that are commonly referred to as layers. The Core Module occupies the top portion (top two layers) of the Cube and provides the CPU,



Ethernet Network Interface Controller (NIC), indicator lights, timing/trigger interface, configuration ports and internal power supply. It's the brains of the Cube and controls the unit's operations. The remainder of the Cube is dedicated to I/O slots or layers. These slots are populated with the I/O modules that are selected to match your process or test application. With over 60 different I/O boards available, we're sure to have just what your application requires (Please see pages 33-46 for more details on I/O boards).

PowerDNA cubes offer a wide variety of mounting options. A flange kit is available for both standard and MIL Cubes to be mounted to a wall or other flat surface. Rack kits and DIN Rail kits are available to allow mounting in 19" racks or on DIN rails, respectively. For portable applications, there is even an attaché-style carrying case that will safely hold a cube, its power supply, cables and screw terminal panels.

### DNR Series RACKtangles and DNF FLATRACKS

RACKtangle and FLATRACK chassis have the advantage when it comes to reconfigurability, maintenance and installation in standard 19" racks. The more conventional, front loading, slide-in installation of RACK I/O boards greatly simplifies reconfiguring your I/O system. Cubes are not difficult to reconfigure, but it will take 10-20 minutes to reconfigure a cube, while less than 30 seconds in a RACKtangle. The backplane within the rack contains no active electronic components, ensuring the rack itself has an almost unlimited MTBF. It also means all active components are on easily replaceable I/O modules, offering an extremely short MTTR in critical applications. Finally, though the cubes can be mounted in 19" racks, the RACKtangle chassis is ready to rack mount without any additional mounting hardware or effort.



## General Description (continued):

The DNR-12-1G chassis provides twelve I/O slots while the smaller DNR-6-1G provides six and the DNF-4-1G FLATRACK offers four. All three provide identical electrical performance and offer an 8347 PowerPC CPU, two Ethernet network interfaces, indicator lights, timing/trigger interface, configuration ports, backplane buffer and power supply. The bulk of the rack is dedicated to the I/O slots. These slots are populated with I/O boards selected to match your application. With over 60 different I/O boards available, we're sure to have just what your application requires.

The RACKtangle is an excellent, modern alternative to VME-based systems. As more and more VME vendors are decommissioning data acquisition and control I/O boards, many customers are being forced to consider alternative platforms. The DNR series is not only new, ensuring long-term availability, its 3U chassis has the distinct advantage of offering equivalent performance in one-half the rack space of a typical 6U VME rack. Don't forget, all of our Cube and RACKtangle products are supported by UEI's 10-Year, Long-Term Availability Guarantee!

### MIL series Cubes and RACKs

For those who need more rugged installations than the standard Cube and RACKtangles, UEI offers the MIL series. The DNR-MIL (12 I/O slots) and DNA-MIL (4 I/O slots) utilize the same electronics as the Cube and RACK, but encapsulate them in a rugged, military ready chassis and provide all I/O connections through 38999 series connectors. Designed to meet the rigors of MIL-STD-810/461/1025 and more, the MIL chassis are an ideal solution in deployed military applications or industrial/in-vehicle applications where extreme ruggedness and reliability are required.

### Communications

All the chassis are designed to connect to the host PC via standard Gigabit 1000Base-T Ethernet (100/10Base-T compatible). Cubes are available with Gigabit, 100Base-T AND 100Base-FX fiber connectivity.

Regardless of form factor, the GigaBit Ethernet-based chassis provide two separate GigE ports. One is designated as the primary, or

control port, while the other resides at a different IP address and is designated as the diagnostic port. This two-port configuration allows system monitoring and diagnostic checks by a computer other than the host. To go along with the diagnostic ports, GigaBit-based chassis also include a wide variety of built-in diagnostic tools. Included in these tools are the ability to measure all internal power supply voltages, monitor internal chassis temperature and

check the operating state of all cooling fans. A block diagram of the Gigabit-based chassis is provided in Figure One.

Rather than providing a second IP address, 100Base-T and 100Base-FX-based cubes include a single point, Ethernet switch. This allows the cubes to be daisy chained to each other, or to other Ethernet devices without requiring an external Ethernet switch

or router. A block diagram of the 100Base-T and 100Base-FX is provided in Figure Two.

A variety of Ethernet-based communication "modes" provide the interface between the host PC and the Cube or RACKtangle. Largely transparent to the user and fully compliant with standard Ethernet operation, these communications modes have been optimized for certain application types. The first is simple, single point, programmed I/O. This mode is simple and is suitable for most systems where high speed or precise sample timing are not required. The second mode is the ACB (Advanced Circular Buffer). In ACB mode, data is written to and/or read from buffers on the I/O boards rather than directly to/from the Ethernet port. ACB mode is preferred for high speed acquisition/control or where precise sample timing is required, as the buffers are large enough to ensure data is never lost due

to Ethernet timing latencies. The third mode is DMAP. In DMAP mode, Cubes use our patented DAQBIOS Ethernet protocol to ensure deterministic real-time performance and achieve sub-millisecond response times across more than 1,000 I/O (analog and/or digital) points. Finally, there are two high-speed VMAP messaging modes that allow real-time performance when transferring data to and from any of the communications I/O boards (e.g., the ARINC-429, MIL-STD-1553 or CAN-bus interface).

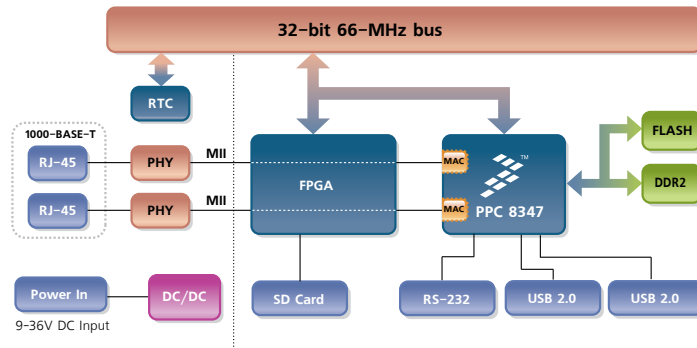

Figure One: Gigabit Chassis block diagram

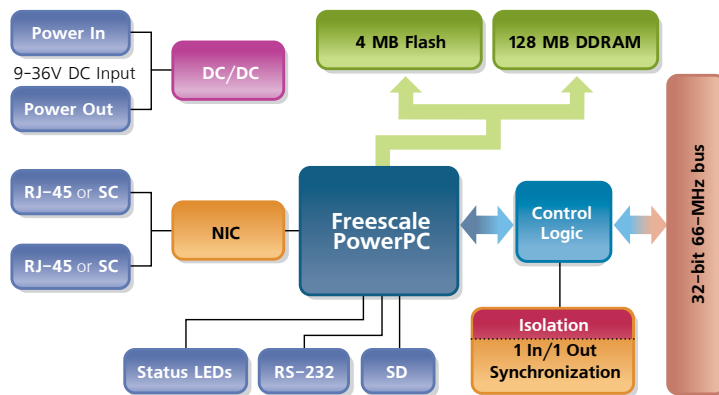

Figure Two: 100Base-T/FX Chassis block diagram

## General Description (continued):

### I/O boards

DNR/DNF series RACKs and DNA series Cubes are compatible with a wide variety of I/O boards, currently numbering over 60. Cube and RACK I/O boards are electronically identical and differ only in connector type and mechanical configuration. All I/O boards are electrically isolated from both the chassis in which they are installed, as well as all other boards within the chassis. All connections are made via standard 37- and 62-pin "D" connectors on standard chassis and through 38999s on the DNA- and DNR-MIL, so building a custom cable is never a problem. Easy-to-use screw terminal panels are available for all boards, and special function boards such as the ICP/IEPE, and MIL-1553 interfaces include interface boards/cables with the standard coaxial connections.

I/O boards may be used in any combination, meaning a 12-slot RACKtangle has over  $2 \times 10^{20}$  combinations. In addition to standard analog and digital input and output boards, UEI offers; ARINC-429, MIL-1553, AFDX, CAN, RVDT/LVDT (input and simulated output), Synchro/Resolver (input and simulated output), RS-232/422/485, strain gauge simulated output, Quadrature encoder, high voltage analog output (up to 115 VDC), high drive analog output (up to 200 mA) and much more. UEI's popular Guardian series boards provide a host of powerful diagnostics and have been extremely popular in simulator applications as well as other applications requiring high system up-time and maintainability.

### Software

No system is complete without software. The DNA/DNR/DNF series is supported by all the popular versions of Windows, Linux and Real-time operating systems. Our UEIDAQ Framework provides a simple and universal API and supports all common programming languages. The Cube is also fully supported by an extensive array of application packages, including LabVIEW, MATLAB, DASyLab and more.

### Conclusion

Whether your application requires a few I/O channels or many thousands, the DNA Cubes and DNR/DNF RACKs will provide an ideal solution. The Cube's unique combination of flexibility, compact size, mechanical and electrical ruggedness, and ease of use is unparalleled. The new DNA- and DNR-MIL and their 38999 connectors bring the Cube/RACK concept to applications that require the popular 38999 style connectors. The RACKs are compact (3U std, 4U MIL or 1U), rugged Ethernet I/O chassis in a more conventional form factor.

## Typical Applications:

- Flight simulators
- Aerospace test
- Land and ground vehicle simulators
- In-Vehicle test
- Environmental/HVAC control
- Vehicle NVH testing
- Machine control
- Medical equipment
- Offshore monitoring and control
- Power generation monitoring and control
- Semiconductor manufacturing

## Power DNA/DNR Advantages:

### Easy to Configure and Deploy

- Over 60 different I/O boards available
- Built-in signal conditioning
- Standard COTS products and delivery
- 10-year guaranteed availability
- Upgradable to UEIPAC and UEISIM configurations

### True Real-Time Performance

- <250  $\mu$ sec updates guaranteed with 1000 I/O
- Up to 6 million samples per second (GigE)
- Use QNX, RTX, RTAI Linux, VxWorks and more

### Easily Distributed with Flexible Connectivity

- Cubes offer 100Base-T, 100Base-FX or Gigabit Ethernet
- RACKs offer Gigabit Ethernet with built-in diagnostic port
- GigE chassis have dual Ethernet ports will operate as Control/diagnostic port, or teamed/bonded for redundant network control.

### Compact Size:

Cubes; (up to 150 A/D, 192 D/A, 288 DIO, 48 Serial ports per cube!)

- 4.1" x 4.0" x 4.0" provides 3 I/O slots
- 4.1" x 4.0" x 5.8" provides 6 I/O slots
- 4.1" x 4.0" x 6.75" provides 4 I/O slots and 38999 connectors

RACKtangles; (up to 300 A/D, 384 D/A, 576 DIO, 96 Serial ports per RACK!)

- 12 I/O slots in a standard 3U rack mount chassis
- 12 I/O slots in a 17.5" x 8.125" x 7" military style DNR-MIL I/O rack
- 6 I/O slots in a 10.5" x 5.75" x 5.25" HalfRACK
- 4 I/O slots in a standard 1U FLATRACK

### Low Power:

- RACKs and GigE cubes require <10 watts (not including I/O)
- 100Base-T cubes require < 4 watts (not including I/O)

### Rugged and Industrial:

- Solid aluminium construction
- 100Base-T Cubes operation tested from -40 °C to +85 °C
- GigE Cubes and RACKs operation tested from -40 °C to +70 °C
- Vibration tested to 3 g, (100Base-T cubes to 5 g)
- Shock tested to 50 g (operating), 100 g for Cubes

### Outstanding Software Support

- Windows, Linux, RTX , VxWorks and QNX operating systems
- VB, VB .NET, C, C#, C++, J#
- MATLAB, LabVIEW, DASyLab, OPC and ActiveX support
- EPICS (Experimental Physics and Industrial Control System)
- Nagios computer system monitoring support

- VME system replacement
- Bridge and tunnel monitoring
- Nuclear plant and power station simulators
- Sequence of events recorders
- Wind tunnel control and monitoring
- Solar and wind power generation control/monitoring
- Dynamometer control
- Airframe structural test
- Jet engine test stands
- Environmental chamber monitoring and control
- Machine health monitoring
- Plus many, many more!

# Software support for all popular languages, operating systems and applications:

Whether using our DNA Cubes, DNR/DNF RACKs (or PowerDAQ PCI and PDXI boards), programming your data acquisition and control system has never been easier.

## Windows up to Windows 8 (including 64-bit)

Based on Object-Oriented Programming (OOP) techniques, the UEI-DAQ Framework library uses the same API for the Cube, RACKtangle and PowerDAQ board families. The Framework dramatically reduces the amount of code you'll need to write in order to complete your data-acquisition and control applications. The Framework library comes with bindings for all major programming languages and DAQ/control applications including MATLAB, LabVIEW and DASyLab. Our library adds simulated hardware that allows you to test-drive our software (or start developing your application) without any DAQ hardware. The UEIDAQ library is included with all UEI

DAQ hardware at no charge. It is available for download from the UEI website.

## Linux, QNX, VxWorks, InTime and other RTOS.

UEI offers extensive drivers/support for Linux and all popular Real-time Operating Systems, including QNX, InTime, VxWorks, and RTAI Linux. These are factory developed and supported drivers. Though many DAQ firms have ignored the Linux/RTOS market, or relegated their support to unofficial user forums, UEI provides complete drivers for their data-acquisition hardware, including factory support. All Linux drivers as well as those for most RTOS are included with the product and are available for download on our web site. There is a small charge for QNX and VxWorks drivers.

Visit [www.ueidaq.com/download](http://www.ueidaq.com/download) today to download and "test-drive" our software!

## WINDOWS: 32/64-bit XP, Vista, 7, 8 [Hosted Systems]

UEIDAQ Framework Library Architecture

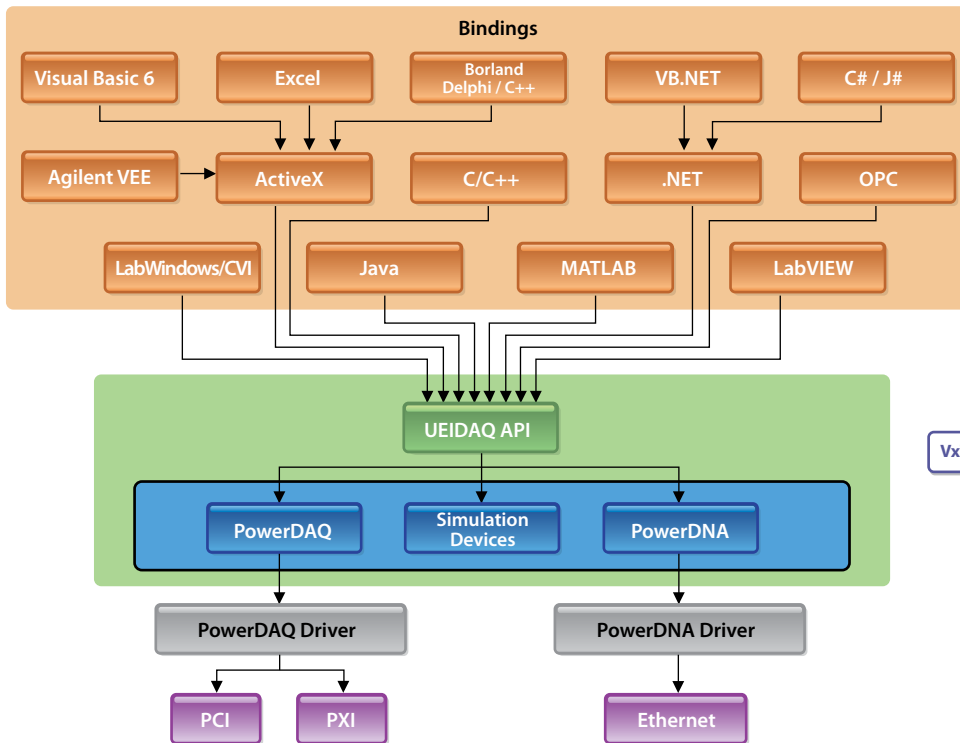

## LINUX & REALTIME Operating Systems/Extensions

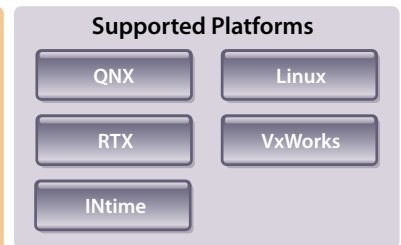

## RealTime Embedded Systems

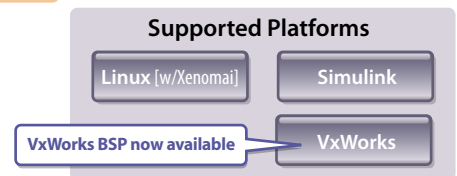

Cubes and RACKs can run stand-alone with a Linux OS. Please see the UEIPAC on pages 10-13 for more info on this powerful platform!

## EPICS:

EPICS (Experimental Physics and Industrial Control System) is a very popular software interface in many high-energy physics laboratories. UEI's EPICS software allows you to run your Cube or RACK as a CAS (Channel Access Server), allowing you to configure any I/O input or output as a PV (Process Variable). This support is provided for both PowerDNA and UEIPAC based systems. EPICS support is included with our standard software distribution and is included in the price of the hardware.

## REFLECTIVE MEMORY / SCRAMNET REPLACEMENT

UEI's Cubes and RACKs are ideal replacements for aging reflective memory or SCRAMnet based systems. Our DMAP/VMAP Ethernet protocols ensure real-time transfer of the I/O data between the RACK and your host without special RM/SN hardware. If your application also requires host-to-host data sharing, we recommend a third-party DDS. These products allow data sharing among PCs over a standard Ethernet link rather than requiring expensive, dedicated Reflective Memory hardware. We have fully tested our systems with PrismTech's OpenSplice™ and RTI Connex™ DDS packages.

# Diagnostic and set-up software

UEI's PowerDnX systems provide outstanding operating system, programming language and application package support, but that is far from the end of the story. All UEI Cubes and RACKs also include a host of helpful and powerful system setup, diagnostics and test software.

## PowerDNA Explorer

PowerDNA explorer is the primary diagnostic and system setup tool and is available in both Windows and Linux. Explorer is based on a very straightforward GUI that allows you to perform the following tasks.

- Scan the network for Cube/RACKs and identify those attached.
- Connect to the Cube/RACK and verify proper Ethernet connectivity.
- Determine the Revision level of the Cube/RACK as well as all I/O boards installed and create a text file of the information.
- Update the Cube or RACK firmware.
- Test I/O board's functionality by reading inputs and writing outputs.
- Read all power supply voltages and input current as well as internal temperatures on GigE Cubes and RACKs.
- Display the I/O connector Pinout of all I/O boards installed.
- Set I/O board input and output ranges, store the settings, retrieve the settings and provide the info in an external text file. Allows you to easily test each I/O point in a system with the appropriate ranges and document those ranges for future usage.

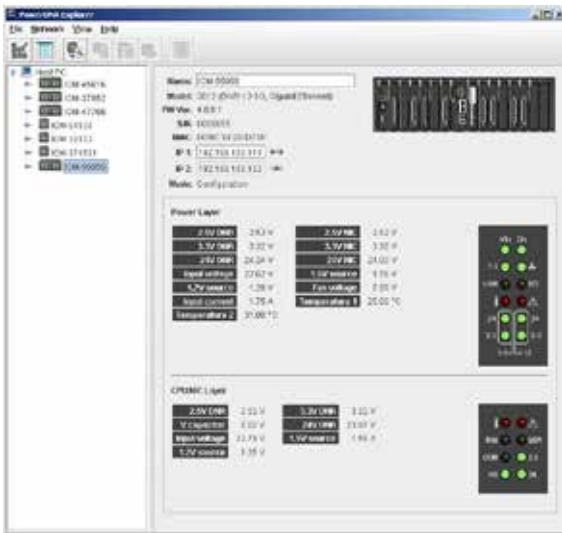

PowerDNA Explorer confirms proper connection as well as displaying power supply voltages and internal temperatures of GigE Cubes and RACKtangles.

## Session Manager

Session Manager is a diagnostic tool that allows you to configure and test I/O boards and display input data on a simple chart recorder GUI. Session manager allows you to test AC power and dynamic aspects of your system not available in PowerDNA Explorer.

## Spectrum Analyzer

Spectrum Analyzer is an easy-to-use tool that allows you to set up and read analog inputs at high sample rates. The data is then displayed real-time on an oscilloscope GUI. Click a single tab and the display switches from time domain to frequency domain and a real-time plot of the FFT is depicted.

## Excel Add-In

Intended primarily as a diagnostics and PowerDNA test tool, the Excel Add-in allow you to set up applications within Excel itself and acquire data directly into the spreadsheet. The Excel setup GUI is quite straightforward though is limited in that it will only acquire data from a single board at a time.

## Nagios® Support

The UEI software suite now includes support for Nagios IT infrastructure monitoring tools. This tool provides high-level system diagnostics allowing users to spot problems before they cause a problem and quickly solve those problems that do occur.

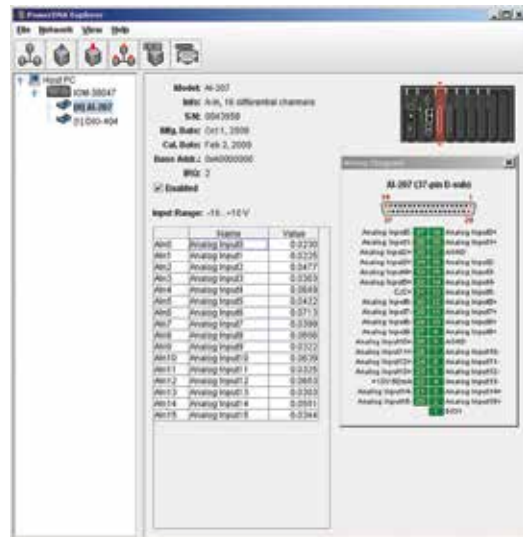

Explorer also serves as a diagnostic tool with I/O boards showing the slot selected and I/O board pin-out. You may also test the inputs/outputs with a live read/write.

## Ordering Guide: Ultra Compact Gigabit Ethernet I/O modules

Part Number	Description (Includes Chassis, Power Supply, Ethernet and Serial cables and software CD)
DNA-PPC5	100Base-T 3-slot I/O Cube, PowerPC CPU, sync interface, (upgradable to UEIPAC/UEILogger/UEISIM/UEIModbus)
DNA-PPC8	100Base-T 6 slot I/O Cube, PowerPC CPU, sync interface, (upgradable to UEIPAC/UEILogger/UEISIM/UEIModbus)
DNA-FPPC5	100Base-FX fiber-based I/O Cube, 3 I/O slots, PowerPC CPU, sync interface, (upgradable to UEIPAC/UEISIM/UEIModbus)
DNA-FPPC8	100Base-FX fiber-based I/O Cube, 6 I/O slots, PowerPC CPU, sync interface, (upgradable to UEIPAC/UEISIM/UEIModbus)
DNA-PPC5-1G	Gigabit Ethernet Cube, 3 I/O slots, PowerPC CPU, sync interface, (upgradable to UEIPAC/UEISIM/UEIModbus configuration)
DNA-PPC8-1G	Gigabit Ethernet Cube, 6 I/O slots, PowerPC CPU, sync interface, (upgradable to UEIPAC/UEISIM/UEIModbus configuration)
DNA-MIL	Gigabit Ethernet Cube, 4 I/O slots, 38999 connectors, PowerPC CPU, sync interface, (upgradable to other configurations)
UEINet	Gigabit Ethernet Cube, 1-slot I/O Cube, PowerPC CPU, sync interface, (upgradable to UEIPAC/UEILogger/UEISIM/UEIModbus)
DNF-4-1G	Gigabit Ethernet 1U FLATRACK, 4 I/O slots, PowerPC CPU, sync interface, (upgradable to other configurations)
DNR-6-1G	Gigabit Ethernet RACKtangle, 6 I/O slots, PowerPC CPU, sync interface, (upgradable to UEIPAC/UEISIM/UEIModbus)
DNR-12-1G	Gigabit Ethernet RACKtangle, 12 I/O slots, PowerPC CPU, sync interface, (upgradable to UEIPAC/UEISIM/UEIModbus)
DNR-MIL	Gigabit Ethernet RACK, 12 I/O slots, 38999 connectors, PowerPC CPU, sync interface, (upgradable to other configurations)

For I/O boards (layers), see pages 33-46. For accessories including cables, screw terminal boards and mounting options, see page 47.

# DNx Chassis: Technical Specifications

Computer Interface	PPCx series Cubes	PPCx-1G series GigE Cubes	RACKtangle Chassis
Primary Ethernet Port	10/100Base-T, RJ-45 connector	10/100/1000Base-T, RJ-45 connector	10/100/1000Base-T, RJ-45 connector
Diagnostic Port	not applicable	10/100/1000Base-T, RJ-45 connector	10/100/1000Base-T, RJ-45 connector
Daisy chain output	10/100Base-T, RJ-45 connector	n/a	n/a
Optional Interface	100Base-FX Fiber( single or multi mode)	n/a	n/a
Config/Serial Port	RS-232, 9-pin "D"	RS-232, 9-pin "D"	RS-232, 9-pin "D"
USB Port	not supported	USB 2.0	USB 2.0
Sync	DNA-SYNC-1G series cables and boards provide system clock or trigger synchronization	DNA-SYNC-1G series cables and boards provide both clock and trigger sync signals	DNA-SYNC-1G series cables and boards provide both clock and trigger sync signals
I/O Board Support			
Series supported	All DNA-series boards	All DNA-series boards	All DNR-series boards (DNF for FLATRACK)
Processor/system			
CPU	Freescale MPC5200, 400 MHz, 32-bit	Freescale 8347, 400 MHz, 32-bit	Freescale 8347, 400 MHz, 32-bit
Memory (RAM)	128 MB (64 MB available for application SW)	128 MB (100 MB available for application SW)	128 MB (100 MB available for application SW)
Memory (Flash)	4 MB (0 MB available to user SW)	32 MB (16 MB available to user SW)	32 MB (16 MB available to user SW)
Host Communications			
Distance from host	100 meters max, CAT5 cable	100 meters max, CAT5 cable	100 meters max, CAT5 cable
Ethernet data transfer rate	2 megabyte per second	20 megabyte per second	20 megabyte per second
Analog data transfer rate	up to 1 megasample per sec (16-bit samples)	>6 megasample per second. Capable of sustained transfer in any cube configuration	up to 6 megasample per sec (16-bit samples)
DMAP I/O mode	update 1000 I/O channels < 1 millisecond, guaranteed (analog and/or digital)	< 250 microsecond, guaranteed (analog and/or digital)	update 1000 I/O channels < 250 microsecond, guaranteed (analog and/or digital)
Physical Dimensions / Weight			
3 I/O slots	PPC5: 4.1" x 4.0" x 4.0" / 1.5 lbs.	PPC5-1G: 4.1" x 5.0" x 4.0" / 1.8 lbs.	n/a
4 I/O slots	n/a	DNA-MIL: 4.5" x 6.75" x 7.35" / 11 lbs.	DNF-4-1G: 1.75" x 7.5" x 16.5" / 3.0 lbs.
6 I/O slots	PPC8: 4.1" x 4" x 5.8" / 1.8 lbs.	PPC8-1G: 4.1" x 5.0" x 5.8" / 2.3 lbs.	DNR-6-1G: 5.25" x 6.2" x 10.5" / 3.9 lbs.
12 I/O slots	n/a	n/a	DNR-12-1G: 5.25" x 6.2" x 17.5" / 5.5 lbs. DNR-MIL: 7.0" x 8.1" x 17.5" / 22 lbs.
Environmental (see pgs 26-28 for DNA-MIL and DNR-MIL)			
Electrical Isolation	350 Vrms	350 Vrms	350 Vrms
Temp (operating)	-40 °C to 85 °C	-40 °C to 70 °C	-40 °C to 70 °C
Temp (storage)	-40 °C to 100 °C	-40 °C to 85 °C	-40 °C to 85 °C
Cooling Fan	Optional, suggested for application where total Cube power dissipation exceeds 15 watts	Included. Fan is automatically controlled and runs only when internal cube temperature exceeds 40 °C.	Included. Fan is automatically controlled and runs only when internal RACK temperature exceeds 40 °C
Humidity	0 to 95%, non-condensing	0 to 95%, non-condensing	0 to 95%, non-condensing
Vibration			
(IEC 60068-2-64)	10–500 Hz, 5 g (rms), Broad-band random	10–500 Hz, 3 g (rms), Broad-band random	10–500 Hz, 3 g (rms), Broad-band random
(IEC 60068-2-6)	10–500 Hz, 5 g, Sinusoidal	10–500 Hz, 3 g, Sinusoidal	10–500 Hz, 3 g, Sinusoidal
Shock			
(IEC 60068-2-27)	100 g, 3 ms half sine, 18 shocks at 6 orientations; 30 g, 11 ms half sine, 18 shocks at 6 orientations	100 g, 3 ms half sine, 18 shocks at 6 orientations; 30 g, 11 ms half sine, 18 shocks at 6 orientations	100 g, 3 ms half sine, 18 shocks at 6 orientations; 30 g, 11 ms half sine, 18 shocks at 6 orientations
Altitude	70,000 feet (special version to 120,000')	70,000 feet, maximum	70,000 feet, maximum
Power Requirements			
Voltage	9 - 36 VDC (115/220 VAC adaptor included)	9 - 36 VDC (115/220 VAC adaptor included)	9 - 36 VDC (115/220 VAC adaptor included) DNF has AC and DC versions
Power	3.5 Watts (not including I/O boards)	8 Watts (not including I/O boards)	10 Watts (not including I/O boards)
Reliability			
MTBF	>300,000 hrs	>160,000/130,000 hrs std/MIL	>130,000 / 160,000 hrs DNR-12 / DNR-6 >100,000 hrs, DNR-MIL

# UEIPAC 2.0 Cubes and RACKs

## Programmable Automation Controllers

- Powerful stand-alone embedded controller
- Flexible, compact and rugged
- Standard Linux or VxWorks Operating System
- Eclipse IDE support
- **New:** EPICS CAS software included
- **New:** Web/HTML/HTML5 Web Socket interface support.
- Flexible: Over 60 I/O boards available
- SD card and/or USB-based disk
- 100Base-T, 100Base-FX (fiber), or Gigabit Ethernet
- High speed PID loops (e.g., 8 channels > 20 kHz)
- Ideal for HIL (Hardware In the Loop) applications
- Ideal local controller/RTU in SCADA system

### General Description:

The UEIPAC offers an unprecedented combination of flexibility, high performance, low cost and small size. The unit is an ideal solution in a wide variety of measurement and control applications including: Temperature control, Remote/unmanned vehicle control, Hardware in-the-loop (HIL) and more. The UEIPAC is an ideal solution for a host of embedded DAQ applications as it allows systems to be developed without the cost or the additional space required by an external host computer. The UEIPAC is now supporting the VxWorks and Linux operating systems.

### Linux Systems

- Uses standard Linux kernel with Xenomai real-time support
- Program in standard C
- Eclipse IDE support
- Develop on Linux PC or Windows PC in the Cygwin environment

### VxWorks Systems

- Use your existing development license
- Obtain your run-time license from WindRiver
- Our BSP provides everything else you need including examples
- One-time charge for BSP regardless of number of systems deployed

The UEIPAC is supported by all UEI DNA/DNR/DNF and UEI Net series chassis and uses the same I/O boards. There are currently over 60 different I/O boards available including analog input (with up to 24 bit resolution), analog output, digital I/O, MIL-STD-1553, AFDX, ARINC 429/453/708, Serial and CAN communications, counter/timer, quadrature encoder input and more. With this many different I/O boards available, there is sure to be a configuration perfect for your application.



The UEIPAC is available on all Cube and RACK platforms!

A key advantage of the UEIPAC is its standalone application deployment. In PowerDNA systems, the software application is written for, and runs on a host PC that is connected to one or more UEI chassis via Ethernet. In UEIPAC systems, the Linux/VxWorks application runs directly on the UEI RACK or Cube. There is no need for a separate host PC, though you can certainly connect one in a monitoring or supervisory role. This allows smaller, faster, more reliable and higher performance systems. It also eliminates the cost of a dedicated host PC and guarantees long term availability of the identical hardware. This is critical when certifying products through CE or FDA, etc.

### Hardware Block Diagram: (UEIPAC 300/600)

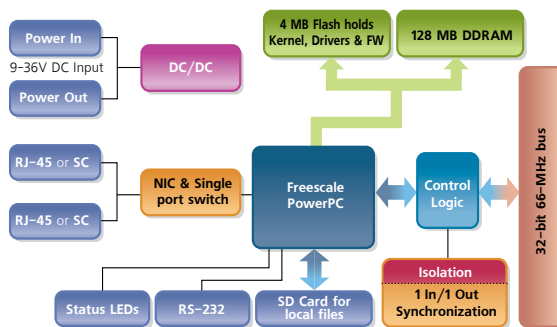

The heart of every UEIPAC is a PowerPC processor running a standard VxWorks or Linux OS. Flash memory contains the OS Kernel and drivers for each of the I/O boards. The CPU board also provides an SD Card slot, Ethernet interface, Inter-cube trigger/sync interface, RS-232 serial port as well as the power supply inputs and a variety of annunciator LEDs. The file system which is contained on the SD card, includes the other components of the operating system such as libraries, utilities, init

script and daemons. The GigE Cubes, RACKs and UEI Net chassis provide a USB 2.0 port usable with external hard drives or memory sticks.

The GigE Cubes, RACKtangles and UEI Net chassis provide dual Ethernet ports, each of which resides at a unique IP address. These are most commonly used to provide separate primary control and diagnostic ports but can also function as teamed/bonded redundant interfaces.

## Linux Programming

Your application runs as a regular Linux process giving you access to the standard POSIX API provided by the GNU C runtime library (glibc) as well as any other library that can be compiled for Linux (for example: libxml, libaudio file...).

New software provided with the UEIPAC includes an EPICS (Experimental Physics and Industrial Control System) Channel Access Server (CAS). Our new LibSharedData software allows easy connection of the UEIPAC to HTML/HTML5 browsers via Web Sockets or other PCs via TCP/IP Sockets.

Whether your application requires a few I/O channels or a few thousand, the UEIPAC is an ideal solution. The UEIPAC's unique combination of Linux operating system, real-time Xenomai support, I/O flexibility, compact size, mechanical and electrical ruggedness, and ease of use is unparalleled.

## UEIPAC Linux TK Programmer's Toolkit

The programmer's toolkit provides the software tools necessary to create an embedded application targeting Linux on the UEIPAC's PowerPC processor. This includes most popular versions of Linux such as Fedora and Suse. The development environment runs on a Linux PC or in the Cygwin environment on a Windows PC. The UEIPAC is also supported by the popular Eclipse IDE. Applications requiring hard real-time functionality are possible using the Xenomai Linux extension.

The UEIPAC development environment includes:

- GCC to cross-compile an application targeting the UEIPAC PPC module
- GNU toolchain tools such as make
- Standard Linux libraries such as glibc
- UEIPAC library for the various I/O boards/devices

The UEIPAC Linux TK is not included with the UEIPAC and must be purchased as a separate item. *Only one Linux toolkit must be purchased, regardless of the number of UEIPAC systems you will deploy.*

The toolkit uses the same API as our popular PowerDNA Cubes, allowing you to reuse existing programs that were designed to run with a PowerDNA Cube over the network. This allows you to develop your application on your desktop, working directly with a "slaved" PowerDNA Cube. Once you are satisfied with your system, you may port the programs to run directly on the UEIPAC Cube with few modifications.

After the UEIPAC power-up, you have a ready to go Linux operating system with FTP and web servers as well as a command line shell accessible from either the serial port or telnet and SSH over the network. You can configure the UEIPAC I/O module to execute your application after booting-up.

## Eclipse IDE support

The UEIPAC is now supported by the Eclipse IDE. Programmers may now take advantage of the many powerful Eclipse tools to build their UEIPAC applications.

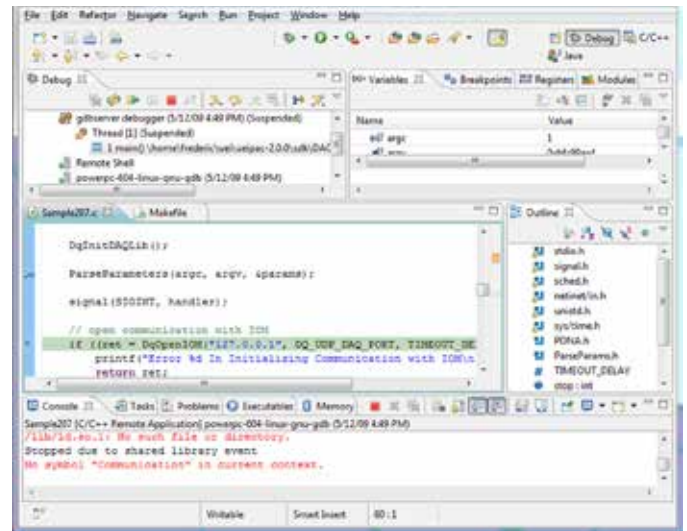

The Eclipse IDE debug screen.

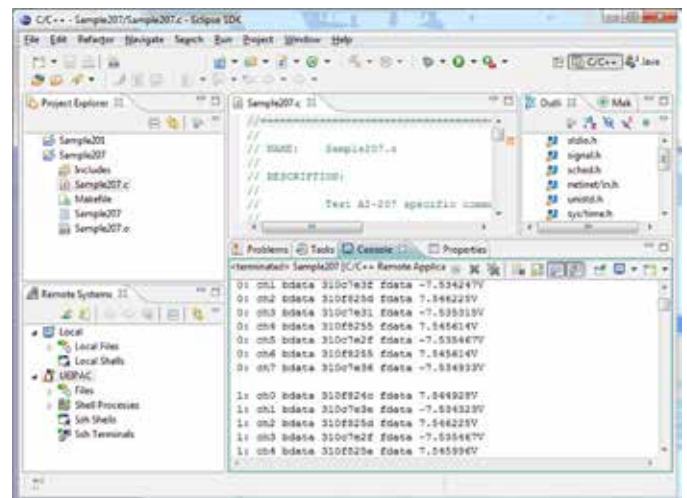

A typical Eclipse IDE run-time screen.

## New Software Support

**EPICS:** (Experimental Physics and Industrial Control System) is popular standard in high-energy physics laboratories. Our new EPICS server provides the source code to set up the UEIPAC as an EPICS CAS (Channel Access Server), allowing you to configure any I/O input or output as a PV (Process Variable).

**Web Browser Interface:** Our new LibSharedData API/library allows easy connection of the UEIPAC to HTML/HTML5 browsers via Web Sockets or other PCs via TCP/IP Sockets. The HTML5 interface is fully compatible with many "mobile" browsers including Safari for iOS and iPhones and iPads and the Android web browser. Of course the standard HTML interface is provided to interface to more general purpose web browsers such as Internet Explorer®.

## VxWorks Programming

You may now take advantage of all the hardware advantages of UEI's popular UEIPAC chassis and continue to develop your applications in VxWorks. This powerful combination provides hard real-time performance, an extremely robust and reliable operating system, allows you to develop your application in a familiar environment and last, but not least, allows you to preserve a great deal of previously written code! To deploy a UEIPAC application running VxWorks you'll need the following.

1. A UEIPAC (any version with GigE Ethernet ports)
2. The "UEIPAC VxW BSP". You only need to purchase the BSP once, regardless of the number of systems you deploy
3. A VxWorks v 6.9.x development system (from Wind River)
4. A VxWorks run-time license for each UEIPAC deployed (also purchased from Wind River)

Though it's beyond the scope of the datasheet to provide details on how to configure and program the UEIPAC in VxWorks, the following is the table shows the chapters included in the current revision of the VxWorks UEIPAC user manual. The steps mentioned should be familiar to existing VxWorks programmers and should help the reader understand the process.

### 1 Configuring and building a VxWorks kernel for UEIPAC

- 1.1 Installing Software
- 1.2 Building a VxWorks kernel for UEIPAC
- 1.3 Booting VxWorks kernel on UEIPAC

### 2 Programming with PowerDNA API

- 2.1 Building PowerDNA library
- 2.2 Building an example as a kernel module

## Ordering Guide:

UEIPAC Chassis	
Part Number	Description
UEINet-PAC	1 I/O slot, GigE chassis
UEIPAC 300	3 I/O slot 100base-T chassis
UEIPAC 600	6 I/O slot 100base-T chassis
UEIPAC 300-1G	3 I/O slot GigE chassis
UEIPAC 600-1G	6 I/O slot GigE chassis
UEIPAC 400F-DC	4 I/O slot FLATRACK, DC powered
UEIPAC 400F-AC	4 I/O slot FLATRACK, AC powered
UEIPAC 400-MIL	MIL series 4 I/O slot chassis
UEIPAC 600R	6 I/O slot RACKtangle
UEIPAC 1200R	12 I/O slot RACKtangle
UEIPAC Linux TK (Software Only)	UEIPAC Linux Programmer's Toolkit.
UEIPAC VXW BSP	UEIPAC VxWorks Programmers Kit

For I/O Boards / Layers, see pages 33-46. For accessories including cables, screw terminal boards and mounting options, see pages 47.

## UEIPAC: Technical Specifications

Computer Interface	MIL series ruggedized chassis
Primary Ethernet Port	10/100/1000Base-T, 38999 connector
Diagnostic Port	10/100/1000Base-T, 38999 connector
Net Teaming/bonding	supported in both Linux and VxWorks deployments
Config/Serial Port	on LAN/COM 38999 connector
USB Port	USB 2.0 fully supported
Synch Options	Sync input/output port is fully supported
I/O Board Support	
Series supported	All DNx-series boards
Software / Operating System	
Embedded OS	Linux, kernel 2.6.x or VxWorks 6.9.x
Real-time support	Xenomai RTOS support in Linux, VxWorks is a real-time OS
EPICS CAS interface	Yes (Linux version)
SNMP Library	Yes
Processor/system	
CPU	Freescale 8347, 400 MHz, 32-bit
Memory	256 MB (228 MB available for application SW)
FLASH memory	32 MB (20 MB available for user apps)
SD card interface	SD cards up to 32 GB
USB drive interface	Standard USB 2.0 port
Physical Dimensions	
4 I/O slots	UEIPAC 400-MIL: 6.2" x 7.1" x 8.7", 11 lbs.
12 I/O slots	UEIPAC 1200-MIL: 17.5" x 8.1" x 7.0" 22 lbs. (Std 3U)
Environmental	
Temp (operating)	-40 °C to 85 °C (power dissipation of actual system may require derated max temp.)
Temp (storage)	-40 °C to 85 °C
Humidity	0 to 95%, non-condensing
Vibration	
(IEC 60068-2-64)	MIL-STD-810G plus the IEC specs below 10-500 Hz, 5g (rms), Broad-band random
(IEC 60068-2-6)	10-500 Hz, 5g, Sinusoidal
Shock	
(IEC 60068-2-27)	MIL-STD-810G plus the IEC specs below 100g, 3ms half sine, 18 shocks at 6 orientations; 30g, 11ms half sine, 18 shocks at 6 orientations
Altitude	70,000 feet, maximum
EMI / RFI	Designed to meet MIL-STD-461
Sealing	Default unit sealed to IP 66 or better. Pressure relief valves support continuous altitude changes of 5000 fpm. Units can be configured with bottom weep holes if desired.
Power Requirements	
Voltage	9 - 36 VDC designed to meet MIL-STD-1275
Reliability	
MTBF	>130,000 / 100,000 hrs DNA-MIL/ DNR-MIL



# UEIPAC: Technical Specifications

Computer Interface	PPCx series Cubes	PPCx-1G and UEINet GigE Cubes	RACKtangle Chassis
Primary Ethernet Port	10/100Base-T, RJ-45 connector	10/100/1000Base-T, RJ-45 connector	10/100/1000Base-T, RJ-45 connector
Diagnostic Port	not applicable	10/100/1000Base-T, RJ-45 connector	10/100/1000Base-T, RJ-45 connector
Other Port functions	Daisy chained single port switch provided	Ports may optionally be bonded/teamed	Ports may optionally be bonded/teamed
Optional Interface	100Base-FX Fiber (single or multi mode)	n/a	n/a
Config/Serial Port	RS-232, 9-pin "D"	RS-232, 9-pin "D"	RS-232, 9-pin "D"
USB Port	not supported	USB 2.0 fully supported	USB 2.0 fully supported
Synchronization Options	1. DNA-SYNC series cables/boards provide system clock or trigger synchronization. 2. DNA-IRIG-650 board provides IRIG and GPS time synchronization 3. PTP SW implementation of IEEE-1588	1. DNA-SYNC-1G series cables and boards provide both clock and trigger sync signals. 2. DNA-IRIG-650 board provides IRIG and GPS time synchronization 3. PTP SW implementation of IEEE-1588	1. DNA-SYNC-1G series cables and boards provide both clock and trigger sync signals. 2. DNA-IRIG-650 board provides IRIG and GPS time synchronization 3. PTP SW implementation of IEEE-1588
<b>I/O Board Support</b>			
Series supported	All DNA-series boards	All DNA-series boards	All DNR-series boards
<b>Software / Operating System</b>			
Embedded OS	Linux, kernel 2.6.x or VxWorks 6.9.x	Linux, kernel 2.6.x or VxWorks 6.9.x	Linux, kernel 2.6.x or VxWorks 6.9.x
Real-time support	Xenomai RTOS support in Linux, VxWorks	Xenomai RTOS support in Linux, VxWorks	Xenomai RTOS support in Linux, VxWorks
Dev Language	C/C++, Eclipse IDE support,	C/C++, Eclipse IDE support,	C/C++, Eclipse IDE support
Dev Environments	Linux PC or Cygwin Windows environment	Linux PC or Cygwin Windows environment	Linux PC or Cygwin Windows environment
EPICS CAS interface	Yes	Yes	Yes
SNMP Library	Yes	Yes	Yes
<b>Processor/system</b>			
CPU	Freescall MPC5200, 400 MHz, 32-bit	Freescall 8347, 400 MHz, 32-bit	Freescall 8347, 400 MHz, 32-bit
Memory	128 MB (100 MB available for application)	128 MB (100 MB available for application)	128 MB (100 MB available for application)
FLASH memory	4 MB (0 MB available for user apps)	32 MB (20 MB available for user apps)	32 MB (20 MB available for user apps)
SD card interface	SD cards up to 32 GB (8 GB included)	SD cards up to 32 GB (8 GB included)	SD cards up to 32 GB (8 GB included)
USB drive interface	n/a	Standard USB 2.0 port	Standard USB 2.0 port
<b>Physical Dimensions</b>			
1 I/O slot	n/a	UEINet 2.7" x 4.1" x 4.0"	n/a
3 I/O slots	UEIPAC 300: 4.1" x 4.0" x 4.0"	UEIPAC 300-1G: 4.1" x 5.0" x 4.0"	n/a
4 I/O slots		UEIPAC 400-MIL: 5.25" x 6.75" x 6.0"	UEIPAC 400F 1.75" x 6.2" x 17.5" (Std 1U)
6 I/O slots	UEIPAC 600: 4.1" x 4.0" x 5.8"	UEIPAC 600-1G: 4.1" x 5.0" x 5.8"	UEIPAC 600R: 5.25" x 6.2" x 10.5"
12 I/O slots	n/a	n/a	UEIPAC 1200R: 5.25" x 6.2" x 17.5" (Std 3U) UEIPAC 1200-MIL: 17.5" x 8.1" x 7.1"
<b>Environmental</b>			
Electrical Isolation	350 Vrms	350 Vrms	350 Vrms
Temp (op / storage)	-40 °C to 85 °C / -40 °C to 100 °C	-40 °C to 70 °C / -40 °C to 85 °C	-40 °C to 70 °C / -40 °C to 85 °C
Humidity	0 to 95%, non-condensing	0 to 95%, non-condensing	0 to 95%, non-condensing
<b>Vibration</b>			
(IEC 60068-2-64)	10–500 Hz, 5 g (rms), Broad-band random	10–500 Hz, 3 g (rms), Broad-band random	10–500 Hz, 3 g (rms), Broad-band random
(IEC 60068-2-6)	10–500 Hz, 5 g, Sinusoidal	10–500 Hz, 3 g, Sinusoidal	10–500 Hz, 3 g, Sinusoidal
<b>Shock</b>			
(IEC 60068-2-27)	100g, 3 ms half sine, 18 shocks at 6 orientations; 30 g, 11 ms half sine, 18 shocks at 6 orientations	100 g, 3 ms half sine, 18 shocks at 6 orientations; 30 g, 11 ms half sine, 18 shocks at 6 orientations	100 g, 3 ms half sine, 18 shocks at 6 orientations; 30 g, 11 ms half sine, 18 shocks at 6 orientations
Altitude	70,000 feet (special version to 120,000')	70,000 feet, maximum	70,000 feet, maximum
<b>Power Requirements</b>			
Voltage	9 - 36 VDC (115/220 VAC adaptor included)	9 - 36 VDC (115/220 VAC adaptor included)	9 - 36 VDC (115/220 VAC adaptor included)
Power	3.5 Watts (not including I/O boards)	8 Watts (not including I/O boards)	10 Watts (not including I/O boards)
<b>Reliability</b>			
MTBF	>300,000 hours	>160,000 hours	>130k/160k hrs 1200R / 600R and 400F >100k/120k hrs MIL Cube/ RACK

# UEILogger Cubes

## High Performance Data Logger/Recorders

- Flexible: Select the I/O boards to match your application
- Up to 150 analog or 288 digital inputs per cube
- Sample rates up to 250 ksamples/second
- Real-time diagnostic display *while logging*
- Easy-to-use, intuitive Windows setup/programming
- Stores data to standard SD Card (8 GB card included)
- Supports up to 32 GB SD cards
- Compact:
  - 4" × 4.1" × 4" UEILogger 300
  - 4" × 4.1" × 5.8" UEILogger 600
- Rugged (tested -40 °C to +85 °C, 5 g vib, 100 g shock)
- Built in sensor linearization
- Logs data from serial, CAN, ARINC-429 and MIL-STD-1553
- AC, DC, or battery powered
- Automatic input threshold based alarming
- Program via Ethernet or load the logging/recording configuration from the SD Card



## Features

1. Log to SD cards up to 32 GB
2. Data logging to 250 ksample/sec
3. Log data from MIL-STD-1553
4. Built-in alarm generation to digital outputs

## General Description:

The UEILogger is a powerful, flexible and easy-to-use data logger/recorder suitable for use in a wide variety of applications including flight test, industrial monitoring, aerospace, automotive/in-vehicle, and laboratory applications. Based upon UEI's popular Cube architecture, the UEILogger maintains all of the PowerDNA's flexibility and adds a powerful stand-alone data logging/recording capability.

The UEILogger Cube contains the controller, network and SD card interface, and power supply as well as either three or six I/O slots (UEILogger 300 or 600 respectively). Configure your logger by selecting the I/O boards required to match your application. With over 40 different I/O boards available, there's sure to be a configuration to meet your needs. (Please see pages 33-46 for details on the I/O boards.)

### Performance

The UEILogger supports sample rates up to 250,000 samples per second total, spread across the entire Cube. For example, a 6 slot Logger, full of 16-channel AI-217 boards has 96 input channels. The logger will log all 96 channels at up to 2,604 S/sec, for an aggregate sample rate of 250,000 S/sec.

Data is stored on standard SD Cards up to 32 Gigabyte (8 Gig SD Card included). Logged data may be retrieved via the unit's Ethernet port or the SD Card may be removed from the logger and read by any SD Card reader. A 32 Gigabyte SD Card holds over 8 billion 24-bit A/D readings, enough to sample 96 analog inputs at 100 Hz for over nine days, or 96 channels at 1 Hz for over sixty months!

## Simple and Flexible Setup

Developing the data logging application is simple with the intuitive, Windows-based application provided. There is absolutely no programming required. The software allows you to set input, sample/update rates, signal conditioning, etc., all from simple pull down menus. The software allows you to select automatic conversion of inputs into engineering units. Use the logger's built-in conversions or create your own  $Y = mX + b$  linearization either by providing "m" and "b" directly or taking advantage of our automatic two-point scaling utility, which allows you to build the complete scaling from any two known states of your input. You may also set alarm/trigger conditions for each input channel that will control outputs, sound an audible alarm and/or flash an LED. Please see the screen captures on the following page for more info or download a copy of the UEILogger application and try it out. (visit: [www.ueidaq.com/UEIloggerdemo](http://www.ueidaq.com/UEIloggerdemo))

The UEILogger software converts data on the SD Card (including all configuration information) into formats used by popular DAQ and analysis applications. The software also allows you to review the logged data graphically.

The data logging program may be loaded onto the UEILogger two ways: The logger configuration file may be downloaded via the unit's Ethernet port or it may be written directly to an SD Card. This allows Logger applications to be modified or initiated and data to be extracted by removing/installing an SD card.

## Software / Programming:

The data logger application is very intuitive. The initial screen allows you to select the particular Logger Cube (if there are more than one on the network) as well as the I/O boards you wish to include in your logging application. You configure your application by making selections in *Channels, Clock and Trigger, Alarms* and *Data Tabs*. You may view logged data in the View tab.



Enabling and configuring the scaling and signal conditioning options is a snap. Just select from the options available in the various drop-down boxes. The software allows you to select options based on the installed boards. Resulting data is recorded to the SD-Card which can then be downloaded to your PC.

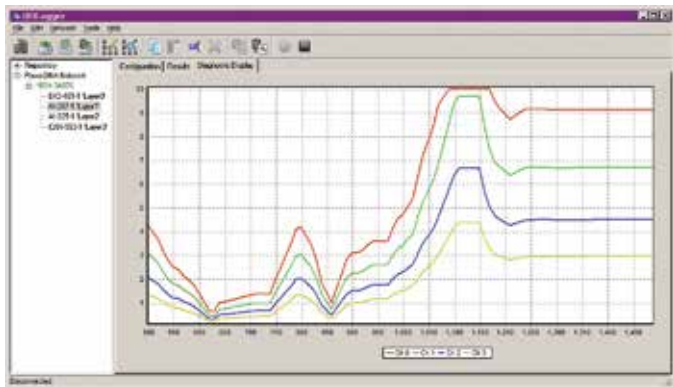

Real-time diagnostic view shown above.

## Typical Applications:

- Flight test
- In-vehicle automotive test
- In-vehicle off-road test
- Environmental/HVAC monitor
- Quality assurance monitor
- Temperature monitor
- Power generation monitor
- Structure stress/strain logging
- Manufacturing process monitor
- Environmental chamber monitor



## Specifications:

Standard Interfaces	
To host computer	10/100Base-T, standard RJ-45 connector
Daisy chain output	10/100Base-T, standard RJ-45 connector
Config/general	RS-232, 9-pin "D"
MTBF	>300,000 hours
I/O Slots Available & Size	
UEILogger 300	3 slots (4.1 × 4.0 × 4.0)
UEILogger 600	6 slots (4.1 × 4.0 × 5.8)
Data Storage	
Storage media	Secure Digital (SD) Card
Storage capacity	32 Gbyte (max), 8 Gbyte SD Card included
Data retrieval	Via Ethernet port or direct SD Card reader
I/O Performance	
Max sample rate	250,000 (24-bit) samples per second, total
Status LEDs	
On front panel	Logging, Attn, R/W, Power, Com Active
Environmental	
Temp (operating)	Tested to -40 °C to 85 °C
Humidity	0 to 95%, non-condensing
Vibration	
(IEC 60068-2-64)	10–500 Hz, 5 g (rms), Broad-band random
(IEC 60068-2-6)	10–500 Hz, 5 g, Sinusoidal
Shock	100 g, 3 ms half sine, 18 shocks at 6 orientations;
(IEC 60068-2-27)	30 g, 11 ms half sine, 18 shocks at 6 orientations
Altitude	70,000 feet (special version tested to 120,000 feet)
Power Requirements	
Input voltage	9-36 VDC 120/240 VAC PS included
Power consumption	3.5 Watt max, plus power required by I/O boards. Total power dissipation: UEILogger 300: < 15 Watts UEILogger 600: < 25 Watts

## Ordering Guide:

UEILogger Order Information (including all software, 8 GByte SD Card, Universal Power Supply and full documentation)	
Part Number	Description
UEILogger 300	5-layer enclosure; room for 3 I/O layers; CPU (PowerPC) + 100Base-T NIC; 24V power supply; installation CD
UEILogger 600	8-layer enclosure; room for 6 I/O layers; CPU (PowerPC) + 100Base-T NIC; 24V power supply; installation CD
UEILogger UPG (software only)	Upgrade to UEILogger package for PowerPC series Cubes; required software/firmware,

For I/O Boards / Layers, see pages 33-46. For accessories including cables, screw terminal boards and mounting options, see pages 47.

# UEISIM Cubes and RACKs

## Simulink® and RTW I/O Targets

- Now supporting Cube, GigE Cube, and RACKtangle chassis!
- Powerful, compact and rugged
- Flexible: Over 60 I/O boards available including A/D, D/A, Digital I/O, Counter/Timer, Quadrature encoder, Serial, CAN and ARINC 429 communications.
- Standard Linux OS (2.6.x Kernel)
- Standard Ethernet 100Base-T or GigE interface
- Supports up to 5,000 “loops” per second
- Ideal for HIL (Hardware-In-the-Loop) applications
- Ideal for development, prototype and production

*The UEISIM UI allows you to remotely monitor signals and tune parameters on a model while it is executing on the UEISIM.*

## General Description:

The UEISIM offers Simulink users a powerful, flexible I/O target. Models built in Simulink are deployed directly on the UEISIM using Embedded Coder. The combination creates a powerful solution for developing and tuning real-time (and non-real-time) applications including model verification, rapid prototyping, and HIL testing. The UEISIM is rugged, flexible, and expandable enough not only to be a great solution while in your development cycle, but also the ideal solution for your production hardware.

To use the UEISIM, simply:

- 1) Build your Simulink application.
- 2) Open MATLAB and select Simulink/Embedded target for UEISIM.
- 3) Convert your model to use the UEISIM I/O blocks (if you had not used them in your original model).
- 4) Create an executable via Embedded Coder, (formerly RTW).
- 5) Connect the UEISIM in “external mode” (if you wish to remotely monitor the application while running on the UEISIM).
- 6) Start your simulation. Six easy steps and your simulation is running live on real hardware.

The UEISIM 300/600 are 4" x 4.1" x 4" / 4" x 4.1" x 5.8" and offer three or six I/O slots respectively. GigE versions of the UEISIM Cubes are designated as the UEISIM 300-1G and UEISIM 600-1G, while four and twelve-slot versions with 38999 connectors are designated the UEISIM 400-MIL and UEISIM-1200-MIL respectively. The RACKtan-



The UEISIM is available on PPC Cube, GigE Cube and RACKtangle platforms!

## UEISIM Hardware Block Diagram:

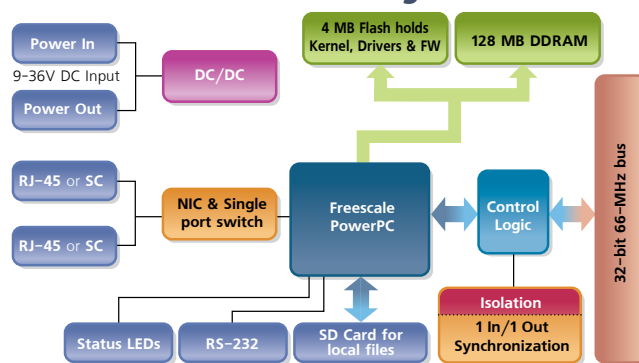

gle-based UEISIM 1200R and UEISIM 600R offer 12 and six slots respectively while the UEISIM 400F is a 4 slot FLATRACK. The -SIM option also allows UEISim functionality on the new UEINet series. The UEISIM uses the same I/O boards as our popular PowerDNA family and includes analog input analog output (up to 32 channels PER BOARD), digital I/O, Serial and CAN communications, ARINC-429 networking, counter/timer, quadrature encoder input and more. With 60+ different I/O boards available, there is sure to be a configuration perfect for your application.

The heart of the UEISIM is a PowerPC processor running a standard (2.6.x) Linux OS kernel. Flash memory contains the OS Kernel and drivers for each of the I/O boards. The CPU/NIC provides an SD Card slot, Ethernet interface, Intercube trigger/sync interface, RS-232 port, power supply inputs and a variety of annunciator LEDs. The file system is contained on the SD card. It includes the other components of the operating system such as libraries, utilities, init script and daemons.

The UEISIM is rugged and robust. With 100Base-T Cubes tested from -40 °C to +85 °C, at 100 g shock, 5 g vibration and altitudes up to 70,000 feet (special version to 120,000 feet) and GigE-based chassis tested from -40 °C to +70 °C, 50 g shock, and 3 g vibration, the UEISIM is tough enough for the most challenging applications. All I/O is isolated from the controller, so the UEISIM is immune to the glitches/spikes common in industrial environments.

## General Description: (continued)

The UEISIM cubes offer a wide variety of mounting options. A flange kit allows the Cubes to be mounted to a wall or other flat surface. Rack kits and DIN Rail kits are available to allow mounting in 19" racks or on DIN rails respectively. UEISIM RACKtangles include flexible mounting ears that allow the RF or portable applications, an attaché style carrying case that will safely hold a cube, its power supply, cables and screw terminal panels. RACKtangle-based UEISIMs include rubber feet for desktop use as well as mounting brackets that allow the RACKtangle and FLATRACK

to be mounted directly into 19-inch racks. The brackets may be mounted on the rear of the RACKtangle allowing the chassis to be mounted on any flat surface or bulkhead.

Whether your application requires a few I/O channels or a few thousand, the UEISIM is an ideal solution. The Cube's unique combination of clean and simple Simulink/RTW target compatible Linux operating system, I/O flexibility, compact size, mechanical and electrical ruggedness, and ease of use are unparalleled.

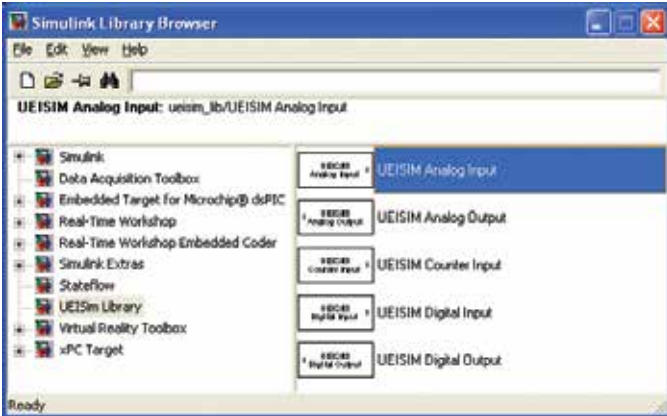

The UEISIM I/O blocks provided are both powerful and easy to use.

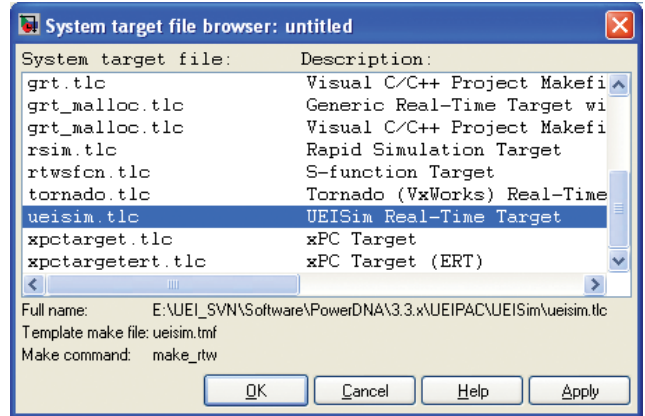

The UEISIM appears as a standard Real-Time-Workshop target.

### Monitoring and Tuning Feature!

The new UEISIM **UI** feature allows remote signal monitoring and parameter tuning while a model is executing on the UEISIM.

It is similar to running the model in external mode under the supervision of Simulink running on a host PC. Use the language of your choice to create the monitoring client application.

Remote monitoring uses the *libshareddata.so* library included with UEISIM and UEIPAC 2.5.0 or greater (*Upgrades are available to current UEISIM/PAC owners at no charge.*) This library eases data communication between a program running on UEIPAC and clients running on network hosts through a simple C or javascript API.

The graphical UI can be programmed on the client side using any language capable of calling functions exported by a C library. In addition, bindings are provided for the following languages: C#, VB.NET, Python and LabVIEW.

The graphical UI can also be implemented as a web application with UEISIM model and Web browser communicating using web-sockets. The HTML behind the UI is served by the UEISIM built-in web server. Signals and parameters can then be monitored from any web browsing device, including smartphones and tablets.

### Ordering Guide:

UEISIM Chassis (includes installed Linux OS, Universal AC power supply, Serial and Ethernet cables and 2 Gbyte SD Card)	
Part Number	Description
UEINet-SIM	Linux-based, Simulink/RTW I/O target with 1 available I/O slots
UEISIM 300	Linux-based, Simulink/RTW I/O target with 3 available I/O slots
UEISIM 600	Linux-based, Simulink/RTW I/O target with 6 available I/O slot
UEISIM 300-1G	Gigabit Ethernet, Linux-based, Simulink/RTW I/O target with 3 available I/O slots
UEISIM 600-1G	Gigabit Ethernet, Linux-based, Simulink/RTW I/O target with 6 available I/O slots
UEISIM 400-MIL	Gigabit Ethernet, Linux-based, Simulink/RTW I/O target with 4 available I/O slots and 38999 connectivity
UEISIM 400R-AC	Gigabit Ethernet, Linux-based, Simulink/RTW I/O target, FLATRACK with 4 available I/O slots, AC powered
UEISIM 400R-DC	Gigabit Ethernet, Linux-based, Simulink/RTW I/O target, FLATRACK with 4 available I/O slots, DC powered
UEISIM 600R	Gigabit Ethernet, Linux-based, Simulink/RTW I/O target, RACKtangle with 6 available I/O slots
UEISIM 1200R	Gigabit Ethernet, Linux-based, Simulink/RTW I/O target, RACKtangle with 12 available I/O slots
UEISIM 1200-MIL	Gigabit Ethernet, Linux-based, Simulink/RTW I/O target with 12 available I/O slots and 38999 connectivity

For I/O Boards / Layers, see pages 33-46. For accessories including cables, screw terminal boards and mounting options, see pages 47.

# UEISIM: Technical Specifications

Computer Interface	PPCx series Cubes	PPCx-1G and UEINet GigE Cubes	RACKtangle Chassis
Primary Ethernet Port	10/100Base-T, RJ-45 connector	10/100/1000Base-T, RJ-45 connector	10/100/1000Base-T, RJ-45 connector
Diagnostic Port	not applicable	10/100/1000Base-T, RJ-45 connector	10/100/1000Base-T, RJ-45 connector
Daisy chain output	10/100Base-T, RJ-45 connector	n/a	n/a
Optional Interface	100Base-FX Fiber (single or multi mode)	n/a	n/a
Config/Serial Port	RS-232, 9-pin "D"	RS-232, 9-pin "D"	RS-232, 9-pin "D"
USB Port	not supported	USB 2.0 fully supported	USB 2.0 fully supported
Sync	DNA-SYNC series cables and boards provide system clock or trigger synchronization	DNA-SYNC-1G series cables and boards provide both clock and trigger sync signals	DNA-SYNC-1G series cables and boards provide both clock and trigger sync signals
I/O Board Support			
Series supported	All DNA-series boards	All DNA-series boards	All DNR-series boards
Software Requirements			
MATLAB	Version 2007b or greater	Version 2007b or greater	Version 2007b or greater
Simulink	Version 7.0 or greater	Version 7.0 or greater	Version 7.0 or greater
Real-Time Workshop	Version 7.0 or greater	Version 7.0 or greater	Version 7.0 or greater
Software / Operating System			
Embedded OS	Linux, kernel 2.6.x	Linux, kernel 2.6.x,	Linux, kernel 2.6.x,
Dev Language	C	C	C
Dev Environments	Simulink / RTW with Cygwin environment on a Windows PC	Simulink / RTW with Cygwin environment on a Windows PC	Simulink / RTW with Cygwin environment on a Windows PC
Processor/system			
CPU	Freescale MPC5200, 400 MHz, 32-bit	Freescale 8347, 400 MHz, 32-bit	Freescale 8347, 400 MHz, 32-bit
Memory	128 MB (100 MB available for application SW)	128 MB (100 MB available for application SW)	128 MB (100 MB available for application SW)
SD card interface	SD cards up to 32 GB	SD cards up to 32 GB	SD cards up to 32 GB
USB drive interface	n/a	Standard USB 2.0 port	Standard USB 2.0 port
Physical Dimensions			
1 I/O slot	n/a	UEINet-SIM 2.7" x 4.0" x 4.1"	n/a
3 I/O slots	UEISIM 300: 4.1" x 4.0" x 4.0"	UEISIM 300-1G: 4.1" x 5.0" x 4.0"	n/a
4 I/O slots	n/a	UEISIM 400-MIL 5.25" x 6.75" x 6.0"	UEISIM 400F: 1.75" x 7.5" x 16.5" (Std 1U)
6 I/O slots	UEISIM 600: 4.1" x 4" x 5.8"	UEISIM 600-1G: 4.1" x 5.0" x 5.8"	UEISIM 600R: 5.25" x 6.2" x 10.5"
12 I/O slots	n/a	n/a	UEISIM 1200R: 5.25" x 6.2" x 17.5" (Std 3U)
12 I/O slots	n/a	n/a	UEISIM 1200-MIL 17.5" x 8.1" x 7.0"
Environmental (please see pgs 26-28 for -MIL series specs)			
Electrical Isolation	350 Vrms	350 Vrms	350 Vrms
Temp (operating)	-40 °C to 85 °C	-40 °C to 70 °C	-40 °C to 70 °C
Temp (storage)	-40 °C to 100 °C	-40 °C to 100 °C	-40 °C to 100 °C
Humidity	0 to 95%, non-condensing	0 to 95%, non-condensing	0 to 95%, non-condensing
Vibration			
(IEC 60068-2-64)	10–500 Hz, 5 g (rms), Broad-band random	10–500 Hz, 3 g (rms), Broad-band random	10–500 Hz, 3 g (rms), Broad-band random
(IEC 60068-2-6)	10–500 Hz, 5 g, Sinusoidal	10–500 Hz, 3 g, Sinusoidal	10–500 Hz, 3 g, Sinusoidal
Shock			
(IEC 60068-2-27)	100 g, 3 ms half sine, 18 shocks at 6 orientations; 30 g, 11 ms half sine, 18 shocks at 6 orientations	100 g, 3 ms half sine, 18 shocks at 6 orientations; 30 g, 11 ms half sine, 18 shocks at 6 orientations	100 g, 3 ms half sine, 18 shocks at 6 orientations; 30 g, 11 ms half sine, 18 shocks at 6 orientations
Altitude	70,000 feet, (special version to 120,000')	70,000 feet, maximum	70,000 feet, maximum
Power Requirements			
Voltage	9 - 36 VDC (115/220 VAC adaptor included)	9 - 36 VDC (115/220 VAC adaptor included)	9 - 36 VDC (115/220 VAC adaptor included). DNF offered in AC or DC
Power	3.5 Watts (not including I/O boards)	8 Watts (not including I/O boards)	12 Watts (not including I/O boards)
Reliability			
MTBF	>300,000 hours	>160,000 hours	>130k/160k hrs 1200R / 600R and 400F >100k/120k hrs MIL Cube/ RACK

# UEIModbus & UEIOPC-UA

## Modbus TCP and OPC-UA embedded servers

- Now supporting Cube, GigE Cube, UEINet and RACKtangle chassis!
- Industry standard Modbus TCP or OPC-UA interface
- Over 40 I/O boards available
- Ethernet 100Base-T or GigE Interface (*Fiber interface available*)
- Rugged: Tested -40 °C to +85 °C  
Tested 5 g vibration, 100 g shock
- DIN rail, 19" rack, or flange mounting options



The UEIModbus is now available on Cube, UEINet, Mil Series Cube and RACK, RACKtangle, HalfRACK, and FLATRACK chassis!

### UEIModbus General Description:

The UEIModbus chassis is a compact, rugged, Ethernet-based data acquisition and control interface that communicates with a host computer or PLC over Modbus TCP. Its flexibility allows you to configure one or more chassis to match the specific I/O requirements of your application. The UEIModbus is ideally suited for a wide variety of industrial monitoring and control applications.

The UEIModbus deployment option is supported by all of UEI's Cube, RACKtangle and FLATRACK form factors. Regardless of your application, we're sure to have a chassis that's an ideal match for your system.

The heart of every UEIModbus system is the Cube or RACKtangle chassis. The UEIModbus 300 cube is 4" x 4.1" x 4" and provides three I/O slots while the UEIModbus 600 is 4" x 4.1" x 5.8" and offers six I/O slots. GigE versions of the UEIModbus Cubes are designated as the UEIModbus 300-1G and UEIModbus 600-1G. The RACKtangle-based UEIModbus 1200R and UEIModbus 600R offer 12 and six slots respectively in a front-loading rack configuration. You select the I/O boards installed in the Cube to match your application. The UEIModbus supports all AI, AO, DI, DO and CT boards compatible with UEI's Cube architecture. (Please see pages 33-46 for details on the I/O boards)

Whether your application requires a few I/O channels or a few thousand, the UEIModbus Cubes/Racks are ideal solutions in your Modbus-based application. For more information on the specifics of the various chassis supported by the UEIModbus, please refer to the specifications provided in the UEIPAC datasheet provide on pages 14-15.

### UEIOPC-UA General Description:

The UEIOPC-UA is an I/O chassis that runs as a standard OPC-Unified Architecture server as defined in IEC 62541. As such it is supported by a huge number of currently available applications packages, but written in-house and by third party developers. The UEIOPC-UA is an ideal solution in a wide variety of Oil & Gas, HVAC, Machine health monitoring as well as host of other industrial control and monitoring functions.

The UEIOPC-UA deployment option is supported by all of UEI's Cube, RACKtangle and FLATRACK form factors. Regardless of your application, we're sure to have a chassis that's an ideal match for your system.

The heart of every UEIUEI system is the Cube or RACKtangle chassis. The UEIOPC-UA 300 cube is 4" x 4.1" x 4" and provides three I/O slots while the UEIOPC-UA 600 is 4" x 4.1" x 5.8" and offers six I/O slots. GigE versions of the UEIOPC-UA Cubes are designated as the UEIModbus 300-1G and UEIOPC-UA 600-1G. The RACKtangle-based UEIOPC-UA 1200R and UEIOPC-UA 600R offer 12 and six slots respectively in a front-loading rack configuration. You select the I/O boards installed in the Cube to match your application. The UEIOPC-UA supports all AI, AO, DI, DO and CT boards compatible with UEI's Cube architecture. (Please see pages 33-46 for details on the I/O boards)

Whether your application requires a few I/O channels or a few thousand, the UEIOPC-UA chassis are ideal solutions in your OPC-UA-based application. For more information on the specifics of the various chassis supported by the UEIOPC-UA, please refer to the specifications provided in the UEIPAC datasheet provide on pages 14-15.

### Ordering Guide:

UEIModbus and UEIOPC-UA Chassis (include preinstalled Modbus/OPC server, universal AC power supply, Serial and Ethernet cables.)		
UEIModbus Part #	UEIOPC-UA part #	Description
UEINet-MOD	UEINet-OPC-UA	Data acquisition and control Cube with 1 available I/O slots
UEIModbus 300	UEIOPC-UA 300	Data acquisition and control Cube with 3 available I/O slots
UEIModbus 600	UEIOPC-UA 600	Data acquisition and control Cube with 6 available I/O slot
UEIModbus 300-1G	UEIOPC-UA 300-1G	Gigabit Ethernet, data acquisition and control Cube with 3 available I/O slots
UEIModbus 600-1G	UEIOPC-UA 600-1G	Gigabit Ethernet, data acquisition and control Cube with 6 available I/O slots
UEIModbus 400-MIL	UEIOPC-UA 400-MIL	Gigabit Ethernet, data acquisition and control Cube with 4 I/O slots and 38999 connectors
UEIModbus 400F-AC	UEIOPC-UA 400F-AC	Gigabit Ethernet, data acquisition and control FLATRACK with 4 available I/O slots, AC powered
UEIModbus 400F-DC	UEIOPC-UA 400F-DC	Gigabit Ethernet, data acquisition and control FLATRACK with 4 available I/O slots, DC powered
UEIModbus 600R	UEIOPC-UA 600R	Gigabit Ethernet, data acquisition and control RACKtangle with 6 available I/O slots
UEIModbus 1200R	UEIOPC-UA 1200R	Gigabit Ethernet, data acquisition and control RACKtangle with 12 available I/O slots

For I/O Boards / Layers, see pages 33-46. For accessories including cables, screw terminal boards and mounting options, see pages 34-36.

# UEINet™ Series Ethernet I/O

## Ultra Compact Gigabit Ethernet I/O modules

10-Year  
Availability  
Guarantee

- Two Gigabit (1000/100/10Base-T) Ethernet Interfaces
  - One port for control, the second for diagnostics or
  - Both ports bonded/teamed for redundant networks
- Compact: 2.7" x 4" x 4.1"
- Over 60 different I/O configurations
- Rugged: 100 g shock, 5 g Vibration, -40 to +70 °C, 70,000 feet
- Real-time: 1000 I/O scans in < 1 millisecond
- Inter-device sync interface
- Complete Windows, Linux, VxWorks, QNX support and more
- LabVIEW™, MATLAB®, DASyLab™ support and more
- Optional deployments include:
  - UEINet-PAC standalone controller with Linux or VxWorks
  - UEINet-Sim, Simulink target
  - UEINet-Mod, Modbus TCP I/O
  - UEINet-OPC-UA, OPC UA server



## General Description:

The UEINet chassis provides ultra-compact Ethernet based I/O module suitable for a wide variety of distributed data acquisition, control and SCADA applications. Based on UEI's popular PowerDNA® Cube architecture, the new series is designed for applications requiring distributed I/O with a very small footprint.

The UEINet chassis is an extremely rugged, Gigabit Ethernet-based I/O interface. With over 60 different I/O boards available, there is sure to be an ideal solution for your application.

UEINet chassis are 2.7" x 4.1" x 4" and are packed with power and flexibility. Each module consists of two primary subsections: a Core Module and an I/O board.

The "standard" UEINet is designed to run as a slave I/O unit controlled directly by a host PC. The UEINet-PAC allows the unit to run as a stand-alone device running an application you write in either Linux or VxWorks operating systems. Simulink users can use the UEINet-SIM to enable the ability to build applications in Simulink. These Simulink modules may run stand-alone on the UEINet-SIM, or in a SCADA mode where a stand-alone application runs, but can be tuned by the host PC. The UEINet-OPC-UA deployment option allows the UEINet to run as an OPC-UA server. Finally, the UEINet-MOD deployment option allows the UEINet to run as a

Modbus TCP node.

The Core Module occupies the top portion of the chassis and provides two independent Gigabit Ethernet Network Interface Controllers (NICs) with separate IP addresses. These may be configured as a control port and a diagnostic port or they may be teamed/bonded to allow redundant network access. The control port is the primary interface from the host PC. The diagnostics port allows other computers (or a different thread on the host) to interrogate the I/O

and system status of the Cube. The Core module also provides the 8347 series PowerPC CPU, two USB 2.0 controller ports (active only with the UEIPAC option), indicator lights, timing/trigger interface, configuration ports and internal power supply.

The remainder of the chassis contains the I/O board. A custom (though fully COTS)

I/O configuration is possible by specifying the UEINet with any of UEI's DNA-series I/O boards. An overview of these board is also provided on the following pages, while detailed specifications can be obtained from the various I/O boards' datasheets. With over 60 different I/O boards available we're sure to have just what your application requires.

Mounting options for the UEINet chassis include both DIN rails and flange mounts.

## UEINet CPU/NIC Block Diagram:

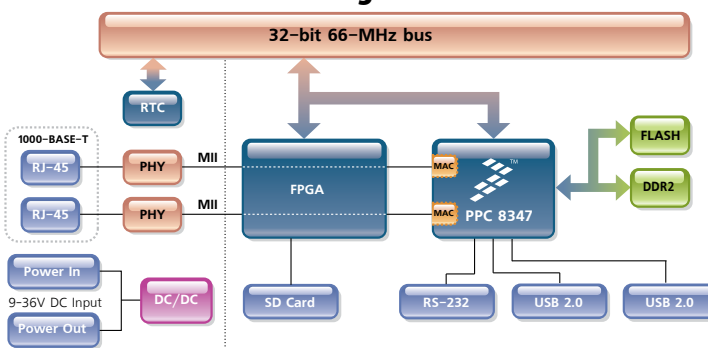



## General Description (continued):

The standard UEINet deployment (also known as PowerDNA mode) the host communicates with the UEINet chassis in one of three ways. The first is simple, single point, programmed I/O. This mode is simple and is suitable for most systems where high speed or precise sample timing is not required. The second is the ACB (Advanced Circular Buffer). ACB mode is preferred for high speed acquisition/control or where precise timing is required as the buffers are large enough to assure data is not lost due to Ethernet timing latencies. The third mode is VMAP/DMAP. In V/DMAP mode, cubes use our patented DAQBIOS Ethernet protocol to assure deterministic real-time performance and achieve sub-millisecond response times across distributed systems including over 1000 I/O (analog and/or digital) points.

No system is complete without software. The UEINet is supported by all the popular Windows, Linux and Real-time oper-

ating systems. Our UEIDAQ Framework provides a simple and universal API and supports all common Windows programming languages. The UEIDAQ Framework also supports an extensive array of application packages including LabVIEW, MATLAB, DASLab and more.

A slightly more complex and powerful API (referred to as the "low-level" driver) supports programmers of Linux, VxWorks and QNX. Though not as simple to use as the UEIDAQ framework, this API is quite simple and powerful. It also exposes more advanced functionality and provides the lower level system control we find most Linux, VxWorks and QNX programmers demand.

The UEINet-FLANGE, allows the UEINet series to be easily mounted to any flat surface. The UEINet-DR, DIN rail mount allows the unit to be mounted to any standard 35 mm DIN rail.

### UEINet Chassis specifications:

Standard Interfaces	
Gigabit Ethernet	Two independent 1000/100/10Base-T interfaces, each with a unique IP address (connected via standard RJ-45 connectors)
USB 2.0	Two ports, one controller, one slave (with optional UEIPAC option only)
Config/General	RS-232, 9-pin "D"
Sync	Custom cable to sync multiple cubes
Host Communications	
Distance from host	100 meters max, CAT5+ cable
Ethernet data transfer rate	20 megabyte per second
Analog data transfer rate	>6 megasample per second. Capable of sustained transfer of any cube configuration
Real-time DMAP I/O mode	update 1000 I/O channels (analog and/or digital) in less than 1 millisecond, guaranteed
Processor	
CPU	Freescale 8347 series, 400 MHz, 32-bit
Memory	128 MB (not including on-board Flash)
Environmental	
Temp (operating)	Tested to -40 °C to 70 °C
Humidity	0 to 95%, non-condensing
Vibration	
(IEC 60068-2-64)	10–500 Hz, 5 g (rms), Broad-band random
(IEC 60068-2-6)	10–500 Hz, 5 g, Sinusoidal
Shock	
(IEC 60068-2-27)	100 g, 3 ms half sine, 18 shocks at 6 orientations; 30 g, 11 ms half sine, 18 shocks at 6 orientations
Altitude	70,000 feet, maximum
MTBF	97,000 to 126,000 hours (depending on version)
Physical Dimensions	
All UEINet chassis	2.7" x 4.1" x 4.0"
Power Requirements	
Voltage	9 - 36 VDC (AC adaptor included)
Power Dissipation	10 - 18 W dependent on I/O board selected

### UEINet Advantages:

#### Easy to configure and deploy

- Over 60 different I/O boards available
- Built-in signal conditioning
- Gigabit Ethernet based (100/10Base-T compatible)
- Flange kit for mounting to wall/flat surface
- Standard COTS delivery and support

#### True Real-time Performance

- 1 msec updates guaranteed with 1000 I/O
- Up to 6 million samples per second
- Use VxWorks, QNX, RTX

#### Flexible Connectivity

- Dual 1000Base-T Gigabit Ethernet ports with independent IPs. Set as control or diagnostic ports or as a redundant network interface
- Dual USB 2.0 controller ports (UEIPAC and UEISIM options only)

#### Stand alone and Modbus options

- UEINet-PAC, standalone controller with Linux or VxWorks
- UEINet-Sim, Simulink target (standalone or hosted by PC)
- UEIMet-MOD, Modbus, Modbus TCP I/O
- UEINet-OPC, OPC server option

#### Rugged and Industrial:

- All Aluminium construction
- Operation tested from -40°C to 70°C
- Vibration tested to 5 g, (operating)
- Shock tested to 100 g (operating)
- All I/O isolated from Cube and host PC.
- Operation to 70,000 feet

## UEINet 1553 Technical I/O Specifications:

General Specifications	
Number channels/ports	2, Independent, Dual redundant interfaces
Specification compliance	MIL-STD-1553a or b including notices 1 & 2
Configuration	Bus Controller (BC), Remote Terminal (RT) or Bus Monitor (BM). <i>Either can may be BC, RT or BM</i>
Interface (software selectable) [measured at connector]	Transformer or direct coupled
Isolation	350 Vrms
Power Consumption	13 W (not including load)
System Data Update Rates (for higher rates please see the DNx-1553-553-900)	
Operation in a standard real-time host-based loop	1 mS min (host-1553-host or 1553-host-1553 round trip)
Operation in asynch 1553 host-based control mode	200 uS typical
Bus Controller (BC) Specs	
Configuration	Independent Ports
Communication support	BC to RT, RT to BC, RT to RT
Messaging protocols	Standard Mode Codes, Broadcast messages
Message timing	Scheduled or asynch with 2 levels of priority
Programmability	Major/minor frame timing, intermessage gap times, time out and late response, BC retries
Error handling	Automatic error detection and recovery.
Remote Terminal (RT) Specs	
Modes	Single or multiple RT emulator (up to 31 different RTs) RT - RT xfers with simulated RTs may be implemented with user software.
RT/BM joint mode	Allows the unit to act as an RT while logging data as an BM
Error handling	Automatic error detection and insertion.
Bus Monitor (BM) Specs	
Monitor modes	Full or selective monitoring by RT address
Monitored parameter	In addition to bus data, BM mode time tags data and capture Word/Message/Error status and RT response time
Environmental	
Operating Temp. (tested)	-40°C to +70°C
Operating Humidity	0 - 95%, non-condensing
MTBF	>100,000 hours

## UEINet 429 Technical I/O Specifications:

Channel Configurations	
Number of channels	6 TX and 6 RX
ARINC Compliance	Fully compliant with ARINC 429
Digital outputs	1 current sinking, FET based
Digital output drive	350 mA max, (500 mA resettable fuse)
Receive Specifications	
Data rate	100 kHz or 12.5 kHz selectable per port
FIFO size	up to 256 32-bit words, user selectable
Receive filter size	1 to 255 labels or disabled
SDI filter	enabled or disabled
New data only filter	enabled or disabled by label or globally
Parity checking	enabled or disabled
Date/Time stamping	enabled or disabled by label or globally
Transmit Specifications	
Data rate	100 kHz or 12.5 kHz selectable per port
FIFO size	256 words
Transmit modes	Scheduled or asynchronous
Scheduler specifications	
timing resolution	100 microseconds
table size	Schedule up to 256 labels per channel
Asynchronous TX modes	
High priority	transmit immediately upon completion of current transmission regardless of schedule
Standard priority	transmit when no scheduled data
FIFO based	transmit when no scheduled, standard or high priority data is being sent
General Specifications	
Loop back testing	Internal loop back connections on the DNx-429-566 allow automatic self-test
Operating temperature	tested -40 °C to +70 °C
Vibration IEC 60068-2-6 IEC 60068-2-64	5 g, 10-500 Hz, sinusoidal 5 g (rms), 10-500 Hz, broad-band random
Shock IEC 60068-2-27	100 g, 3 ms half sine, 18 shocks @ 6 orientations 30 g, 11 ms half sine, 18 shocks @ 6 orientations
Humidity	0 to 95%, non-condensing
MTBF	>115,000 hours
Power consumption	13 Watt, maximum

## UEINet Interface description:

### A Network Connectors

Dual independent Gigabit (1000/100/10Base-T) Ethernet ports, each with a unique IP address.

### B USB Ports

Two USB 2.0 controller ports. Controller port suitable for connection to external peripheral devices. Slave port suitable for connecting the cube to a host computer. (Photo with dual USB ports not available at this time.)

### C SD Card Slot

Secure Digital (SD) Card slot for onboard data storage. The SD Card is used as the data storage media in the UEILogger series. It is also stores both data and linux embedded programs deployed on the cube using the soon to be released embedded toolkit. Supports FAT12, FAT16 and FAT32 filesystems.

### D Serial Port

Using the supplied serial cable, you perform initial PowerDNA set-up of the operating parameters from any serial terminal running at 57,600 baud/8 data bits/no parity/1 stop bit. From a terminal program you can, for instance, change the IP address from the default, if necessary. You also download updated firmware through the serial port. The serial port is usable for RS-232 communications.

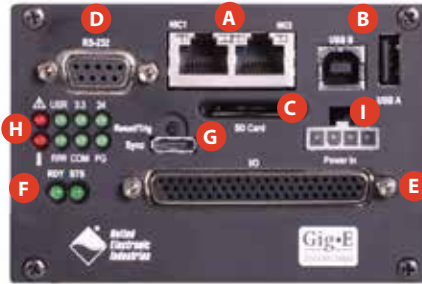

### E I/O Board Slot

The UEINet series can be ordered as a chassis with any DNA-series I/O board. Boards installed in the I/O slot perform the various analog, digital and communications functions you need for your specific application. Your signals may be connected directly to the I/O board via your custom cabling or take advantage of our wide variety of easy-to-use, external screw terminal panels. DNA-series boards ordered with your UEINet chassis are factory installed.

### F I/O Layer Status LEDs

These two green lights give a visual indication of the status of each I/O layer.

**RDY** - Ready • **STS** - Status

### G Sync Connector & Reset Button

High-speed Cube-to-Cube synchronization connector allows multiple cubes to be synchronized. The reset button is recessed to prevent accidental activation, this button resets the CPU layer for activities such as downloading and installing new firmware for the Cube.

### H Cube Status LEDs

These LEDs monitor power supplies, internal temperature, fan operation, CPU heartbeat and input current.

### I Power Connector

Power-In, 9-36V DC either from the DNA-PSU-24 (included with the Cube), or a user-supplied source.

## Pinout Diagrams:

### Power In<sup>1</sup> (molex)



### Serial (RS-232)

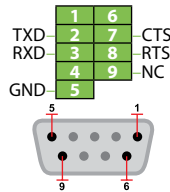

### Synchronization

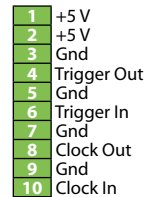

<sup>1</sup> Mating connector available from Digikey, Molex PN 39-01-4040

## Ordering Guide:

Part Number	Description
<b>UEINet Standard Configurations (includes universal AC power supply, serial and ethernet cables)</b>	
UEINet 1553	Dual redundant MIL-STD-1553 interface
UEINet 429	ARINC 429 interface with 6Tx channels and 6 Rx channels
UEINet	UEINet chassis without an I/O board. May be ordered with any of over 60 different DNA-series I/O boards
<b>Options</b>	
UEINet-PAC	Option configures the UEINet as a stand alone Linux based I/O module
UEINet-PAC-VXW	Option configures the UEINet as a stand alone VxWorks based I/O module
UEINet-SIM	Option configures the UEINet to a Simulink target
UEINet-MOD	Option configures the UEINet to support Modbus TCP
UEINet-OPC-UA	Option configures the UEINet as an OPC-UA server
<b>Accessories</b>	
UEINet-FLANGE	Bottom-mount flange assembly allows UEINet to be mounted to any flat surface
UEINet-DR	DIN rail mount for UEINet modules (standard 35 mm)
DNX-CC	Optional conformal coating of all internal boards
DNA-ACCESSORY	PowerDNA accessories kit includes spare universal AC power supply and serial/ethernet cables

# DNA- and DNR-MIL

## Military-Grade I/O Chassis

10-Year  
Availability  
Guarantee

- 4 or 12 I/O slots, (DNA/DNR-MIL)
- Military/Rugged 38999 connectivity
- 100% COTS solution
- Supported by over 60 standard DNA-series I/O boards
- 5 g vibration, 100 g shock, sealed to IP66
- Dual GigE ports (control and diagnostic)
- Designed for MIL-STD-461/810/1275 compliance
- Extensive built-in system diagnostics
- PowerDNA, UEIPAC, UEISIM & UEIModbus configs.
- No rotary cooling devices
- Extensive software support including Windows, Linux, VxWorks, QNX, RTX and more



### General Description

The DNx-MIL chassis are the latest deployment of UEI's popular Cube and RACKtangle I/O families. Designed for use in the toughest environments, the new DNA-MIL offers 4 I/O slots while the DNR-MIL offers 12 I/O slots. Regardless of which you choose, it will be an ideal solution for your military and aerospace deployments. The form factor is also ideal for a huge assortment of commercial applications including use on oil drilling platforms and refineries, heavy machinery, outdoor test stands and any other I/O application that will be exposed to the elements. All connectivity is through ROHS compliant 38999 connectors.

The DNA/DNR-MIL chassis are 100% COTS, made in the USA and supported by UEI's family of over 60 compatible analog, digital and other interface I/O boards.

Electronically, the DNx-MIL is identical to the standard DNA Series Cube except for hold-up and protection circuitry added to the power supply inputs. This power supply conditioning is required in order to meet MIL-STD-1275. This means the DNA-MIL uses our standard DNA Series board (e.g. DNA-AI-217 or DNA-1553-553). With over 50 unique I/O boards and 4 slots available there's sure to be a configuration perfectly matching your application.

The new MIL series is designed to meet the most commonly required elements of MIL-STD-461, -810 and 1025 and are sealed to at least IP66/NEMA6 standards. In addition, no rotary cooling fans are used in the design which maximizes MTBF and mechanical reliability. All internal printed circuit boards are conformal coated to ensure the highest reliability.

The DNx-MIL chassis are available in all of UEI's different deployment options. In PowerDNA, UEIPAC, UEISIM and UEIModbus.

#### **PowerDNA: DNA-MIL and DNR-MIL**

In PowerDNA mode, the DNA-MIL operates as a slave I/O device, running under the control of a host PC. All application

code in this mode is created and run on the host. PowerDNA mode offers almost unprecedented software support including:

- All popular operating systems including Windows, Linux, VxWorks, QNX, RTX and InTime
- All popular programming languages including VB, VB.NET, C, C#, C++, JAVA
- All popular application packages including MATLAB, Simulink, LabVIEW, DasyLAB and more.

#### **UEIPAC 400-MIL and UEIPAC 1200-MIL**

When deployed as a UEIPAC, the standard firmware running on a Cube is replaced by either a Linux or VxWorks operating system. The user then writes the Linux/VxWorks application that runs on the MIL chassis. In this mode, the UEIPAC-MIL can run fully stand-alone, or may be linked to a SCADA host via the Ethernet.

#### **UEISIM 400-MIL and UEISIM 1200-MIL**

Simulink users will appreciate the ability to build models in Simulink, compile them in Embedded Coder and then deploy them on the UEISIM hardware. It's an ideal platform for testing models on actual hardware. Once the model is proven, it can be deployed using the exact same hardware.

#### **UEIModbus 400-MIL and UEIModbus 1200-MIL**

Users needing a compact, rugged Modbus TCP I/O slave will appreciate UEIModbus 400-MIL and UEIModbus 1200-MIL.

Whether your application is on a ship/boat, in an aircraft, in a rocket, on an outdoor test cell, on an oil platform or simply going to be left outside and exposed to the elements, the DNA/DNR-MIL chassis are an ideal solution.

# Technical Specifications

## DNA-MIL and DNR-MIL chassis (Power DNA mode)

Computer Interface	
Primary Ethernet Port	10/100/1000Base-T, 38999 connector
Diagnostic Port	10/100/1000Base-T, 38999 connector
Config/Serial Port	RS-232, 38999 connector
Sync	1. DNA-SYNC-1G series cables and boards provide both clock and trigger sync signals 2. DNA-IRIG-650 board provides IRIG and GPS time synchronization
I/O Board Support	
Series supported	All DNx-series boards
Processor/system	
CPU	Freescale 8347, 400 MHz, 32-bit
Memory (RAM)	256 MB
Memory (Flash)	32 MB
Host Communications	
Distance from host	100 meters max, CAT5 cable
Ethernet data transfer rate	20 megabyte per second
Analog data transfer rate	>6 megasample per second. Capable of sustained transfer in any RACKtangle configuration
DMAP I/O mode	update >1,000 I/O channels at 4 kHz, guaranteed
Physical Dimensions / Weight	
DNA-MIL (4 I/O slots)	6.2" x 7.1" x 8.7" / 11 lbs.
DNR-MIL (12 I/O slots)	7.0" x 8.1" x 17.5" / 22 lbs.
Environmental*	
Electrical Isolation	350 Vrms
Temp (operating)	-40 °C to 70 °C
Temp (storage)	-40 °C to 85 °C
Humidity	0 to 95%, non-condensing
Vibration	
MIL-STD-810G plus the IEC specs below	
(IEC 60068-2-64)	10–500 Hz, 5 g (rms), Broad-band random
(IEC 60068-2-6)	10–500 Hz, 5 g, Sinusoidal
Shock	
MIL-STD-810G plus the IEC stds below	
(IEC 60068-2-27)	100 g, 3 ms half sine, 18 shocks at 6 orientations; 30 g, 11 ms half sine, 18 shocks at 6 orientations
Altitude	70,000 feet, maximum
EMI / RFI	Designed to meet MIL-STD-461
Power Requirements	
Voltage	9 - 36 VDC (AC adaptor available)
Power	10/12 W for 400/1200 (not incl I/O brds)
Power Quality requirement	Designed to meet MIL-STD-1275
Reliability	
MTBF	>130k/100k hours DNA-MIL/DNR-MIL

## UEIPAC 400-MIL and UEIPAC 1200-MIL

Computer Interface	
Primary Ethernet Port	10/100/1000Base-T, 38999 connector
Diagnostic Port*	10/100/1000Base-T, 38999 connector *Alternatively can be teamed/bonded with primary port
Config/Serial Port	RS-232, 38999 connector
USB Port	USB 2.0 fully supported
Synchronization Options	1. DNA-SYNC-1G series cables and boards provide both clock and trigger sync signals. 2. DNA-IRIG-650 board provides IRIG and GPS time synchronization 3. PTP client provides software implementation of IEEE-1588
I/O Board Support	
Series supported	All DNx-series boards
Software / Operating System	
Embedded OS	Linux, kernel 2.6.x or VxWorks
Real-time support	Xenomai RTOS support
Dev Language	C/C++, Eclipse IDE support,
Dev Environmeznsts	Linux PC or Cygwin Windows environment
EPICS CAS interface	Yes
SNMP Library	Yes
Processor/system	
CPU	Freescale 8347, 400 MHz, 32-bit
Memory	256 MB (228MB avail for application SW)
FLASH memory	32 MB (20 MB available for user apps)
SD card interface	SD cards up to 32 GB
USB drive interface	Standard USB 2.0 port
Physical Dimensions	
UEIPAC 400-MIL (4 I/O slots)	6.2" x 7.1" x 8.7" / 11 lbs.
UEIPAC 1200-MIL (12 I/O slots)	7.0" x 8.1" x 17.5" / 22 lbs.
Environmental	
Electrical Isolation	350 Vrms
Temp (operating)	-40 °C to 70 °C
Temp (storage)	-40 °C to 85 °C
Humidity	0 to 95%, non-condensing
Vibration	
MIL-STD-810G plus the IEC specs below	
(IEC 60068-2-64)	10–500 Hz, 5 g (rms), Broad-band random
(IEC 60068-2-6)	10–500 Hz, 5 g, Sinusoidal
Shock	
MIL-STD-810G plus the IEC stds below	
(IEC 60068-2-27)	100 g, 3 ms half sine, 18 shocks at 6 orientations; 30 g, 11 ms half sine, 18 shocks at 6 orientations
Altitude	70,000 feet, maximum
EMI / RFI	Designed to meet MIL-STD-461
Power Requirements	
Voltage	9 - 36 VDC (AC adaptor available)
Power	10/12 W for 400/1200 (not incl I/O brds)
Power Quality requirement	Designed to meet MIL-STD-1275
MTBF	
MTBF	>130k/100k hours 400-MIL/1200-MIL

**Also available in the  
UEIModbus Configuration!**

# Technical Specifications

## UEISIM 400-MIL and UEISIM 1200-MIL

Computer Interface	
Primary Ethernet Port	10/100/1000Base-T, 38999 connector
Diagnostic Port	10/100/1000Base-T, 38999 connector
Daisy chain output	n/a
Optional Interface	n/a
Config/Serial Port	RS-232, 38999 connector
USB Port	USB 2.0 fully supported
Sync	DNA-SYNC-1G series cables and boards provide both clock and trigger sync signals
I/O Board Support	
Series supported	All DNX-series boards
Software Requirements	
MATLAB	Version 2007b or greater
Simulink	Version 7.0 or greater
Real-Time Workshop	Version 7.0 or greater
Software / Operating System	
Embedded OS	Linux, kernel 2.6.x, Xenomai RTOS support
Dev Language	C
Dev Environments	Simulink / RTW with Cygwin environment on a Windows PC
Processor/system	
CPU	Freescale 8347, 400 MHz, 32-bit
Memory	256 MB (228 MB available for application SW)
SD card interface	SD cards up to 32 GB
USB drive interface	Standard USB 2.0 port
Physical Dimensions	
UEISIM 400-MIL (4 I/O slots)	6.2" x 7.1" x 8.7" / 11 lbs.
UEISIM 1200-MIL (12 I/O slots)	7.0" x 8.1" x 17.5" / 22 lbs.
Environmental	
Electrical Isolation	350 Vrms
Temp (operating)	-40 °C to 70 °C
Temp (storage)	-40 °C to 85 °C
Humidity	0 to 95%, non-condensing
Vibration	
MIL-STD-810G plus the IEC specs below	
(IEC 60068-2-64)	10–500 Hz, 5 g (rms), Broad-band random
(IEC 60068-2-6)	10–500 Hz, 5 g, Sinusoidal
Shock	
MIL-STD-810G plus the IEC stds below	
(IEC 60068-2-27)	100 g, 3 ms half sine, 18 shocks at 6 orientations; 30 g, 11 ms half sine, 18 shocks at 6 orientations
Altitude	70,000 feet, maximum
EMI / RFI	Designed to meet MIL-STD-461
Power Requirements	
Voltage	9 - 36 VDC (AC adaptor available)
Power	10/12 W for 400/1200 (not incl I/O brds)
Power Quality requirement	Designed to meet MIL-STD-1275
Reliability	
MTBF	>130k/100k hours 400-MIL/1200-MIL

# Cables, Connectors and Accessories.

## Connectors

All connections to the MIL chassis are made through standard, COTS, nickel plated 38999 connectors. I/O board connections are made through 128-pin connectors where each I/O board utilizes up to 62 of the 128 pins. The Ethernet, USB, diagnostic Serial, Sync, and hardware reset connections are via 37-pin connectors. Power supply and an auxiliary synch bus connections are through a 13-pin connector.

## Cables

Though most customers will design custom cables for their deployed systems, customers working on prototypes and/or those building "one of" systems may desire the ability to connect to the MIL chassis using more traditional, commercial connections (e.g. RJ-45 for the Ethernet ports).

For these customers UEI offers a complete array of cables and screw terminal panels that will provide direct access to all signals routed in and out of the chassis.

## LAN/Power Cables

### DNA-CBL-LAN-06 Communications cable

6 foot cable connecting the 37-pin LAN/COM/USB port connector to standard commercial connectors. Ethernet ports come out to RJ-45, the serial port to a DB-9 and the USB ports to standard USB jacks.

### DNA-CBL-1315-03 Power supply cable

Connects the 13-pin power/sync connector to a standard female DB-15 connector.

## I/O board cables

Each 128 pin I/O 38999 connector provides the I/O connectivity for two I/O slots within the DNA-MIL. UEI I/O boards utilize either 37- or 62-pin D connectors and these connectors are mapped as follows.

"Odd" slots (1 and 3 on the Cube and 1, 3, 5, 7, 9, and 11 on the RACK) map to pins 1-62 on the 128 pin 38999 connectors. "Even" slots map to pins 65-126 on the 38999s. Note that the 37-pin based boards simply do not use pins 38-62. For this reason, most applications use 62-pin cables and screw terminal panels and ignore "no connection" pins. The exception to this is the STP boards that have been specifically designed for use with 37-pin boards (e.g. DNA-STP-207TC). For these boards 37-pin are also available. Also, as some I/O slots may not be utilized in a given application, cables with a single 37-pin or 62-pin D connector are available.

The following cables provide the same I/O connectivity as the standard, commercial DNA-CBL-37S and DNA-CBL-62 series cables.

**DNA-CBL-12862-05:** 5 ft male 128-pin 38999 to 2x DB-62M

**DNA-CBL-12837-05:** 5 ft male 128-pin 38999 to 2x DB-37F

**DNA-CBL-6237M-05:** 5 ft male 38999 to 1x DB-37F and 1x DB-62M

**DNA-CBL-62M-03:** 3 ft male 128-pin 38999 to 1x DB-62M

**DNA-CBL-37M-03:** 3 ft male 128-pin 38999 to 1x DB-37F

## Screw Terminal Panels

**DNA-STP-37** Standard 37-pin screw terminal panel, suitable for use with all 37-pin I/O boards and cables.

**DNA-STP-62** Standard 62-pin screw terminal panel, suitable for use with all 62-pin I/O boards and cables.

**DNA-STP-3762** Universal screw terminal panel, providing both 37- and 62-pin connectors.

# Standard Cube Interfaces

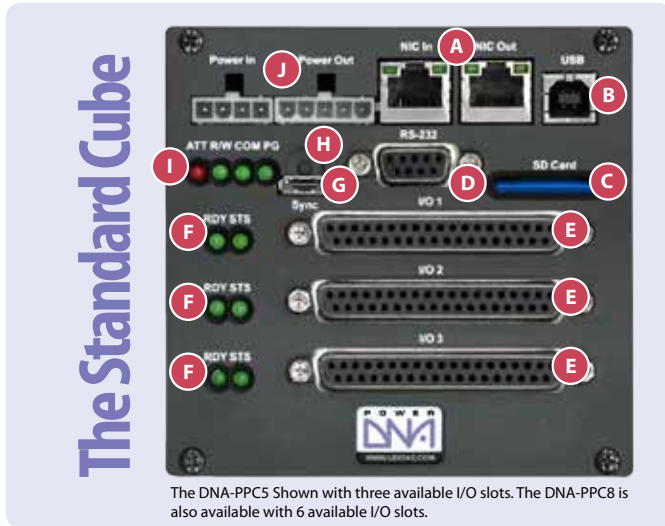

The DNA-PPC5 Shown with three available I/O slots. The DNA-PPC8 is also available with 6 available I/O slots.

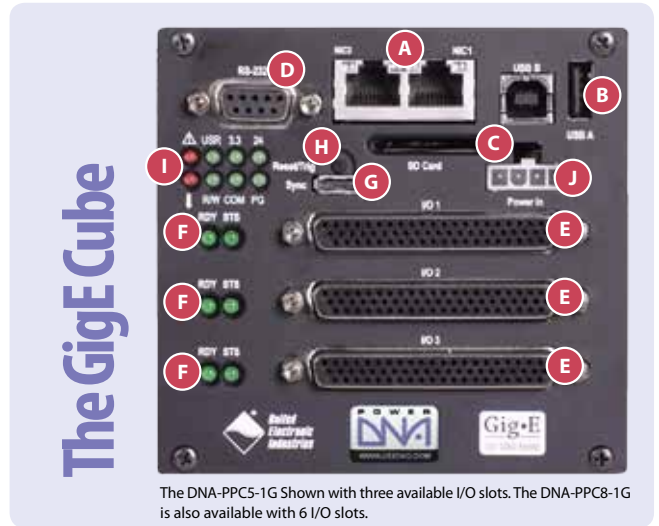

The DNA-PPC5-1G Shown with three available I/O slots. The DNA-PPC8-1G is also available with 6 I/O slots.

## Common Callouts:

### A. Network Connectors

Ethernet connection to the host PC, another Cube or a network switch. Select from models that provide RJ45 jacks for copper cabling or SC-type jacks that accommodate 100Base FX optical cable.

### B. USB Port

USB Ver 2.0 port is not active on 100Base-T Cubes, but is fully supported on GigE-based Cubes and RACKtangle chassis in the UEIPAC and UEISIM operating modes.

### C. SD Card Slot

Secure Digital (SD) Card slot for onboard data storage. The SD Card is data storage media in the UEILogger series. It is also stores both data and Linux embedded programs deployed on the UEIPAC. Supports FAT12, FAT16 and FAT32 file systems.

### D. Serial Port

Using the supplied serial cable, you perform initial PowerDNA setup of the operating parameters from any serial terminal running at 57,600 baud/8 data bits/no parity/1 stop bit. From a terminal program you can, for instance, change the IP address from the default, if necessary. You can also download updated firmware through the serial port. The serial port is usable for RS-232 communications.

### E. I/O Board Slots

Cubes provide either 3 or 6 I/O slots. Boards installed in the I/O slots perform the various analog, digital and communications functions you need for your specific application. Signals may be connected directly to the I/O boards via custom cabling or our easy-to-use, external screw terminal panels. Boards ordered with your cube are factory installed. It is also a simple task to add boards or reconfigure a cube in the field.

### F. I/O Layer Status LEDs

These two green lights give a visual indication of the status of each I/O layer.

### G. Sync Connector

High-speed Cube-to-Cube synchronization connector.

### H. Reset Button

Recessed to prevent accidental activation, this button resets the CPU layer for activities such as downloading and installing new firmware for the Cube.

### I. Communication/System Status LEDs

These LEDs monitor communications through the serial port. LEDs also indicate system status on the Gigabit Ethernet Cube.

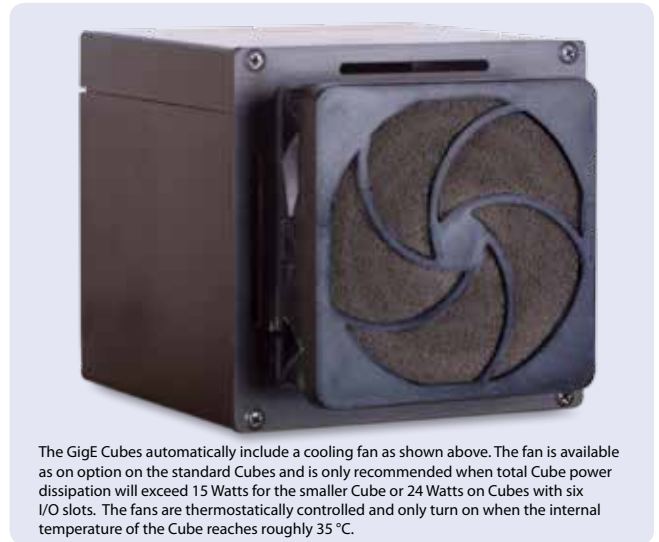

The GigE Cubes automatically include a cooling fan as shown above. The fan is available as an option on the standard Cubes and is only recommended when total Cube power dissipation will exceed 15 Watts for the smaller Cube or 24 Watts on Cubes with six I/O slots. The fans are thermostatically controlled and only turn on when the internal temperature of the Cube reaches roughly 35 °C.

### J. Power Connectors

Power-In, 9 - 36 VDC either from the universal AC power supply (included), a user-supplied source, or daisy-chained from another PowerDNA Cube. Power-Out (same voltage as applied to Power-In) to another Cube. The Gigabit Ethernet Cube has only one power connector. (Daisy Chains not available for GigE Cubes)

## Pinout Diagrams:

### Power In<sup>1</sup> (Molex)

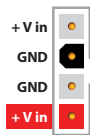

### Serial (RS-232)

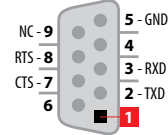

### Synchronization<sup>2</sup>

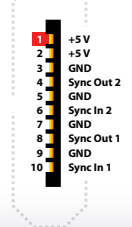

<sup>1</sup>Mating connector available from Digikey, Molex PN 39-01-4040. Please note female insert pins must be purchased separately.

<sup>2</sup>GigE Cube sync pinout.

# DNR RACKtangle™ Layout

## Protected On/Off Switch

The On/Off switch is mounted within two metal shields that ensure the switch will not be inadvertently turned on or off.

## Power Supply Module

Power-In, 9 - 36 VDC either from the DNA-PSU-24-180 (included with the rack), or a user-supplied source. All power supplies are monitored. Power supply status is supplied to the CPU module and displayed on annunciator LEDs.

## I/O Slots

The DNR rack provides 12 I/O slots. All combinations of DNR-series I/O boards are allowed offering literally trillions of possible configurations. DNR series I/O boards are fully plug-and-play. There is no hardware configuration required. Empty slots are covered with blank panels to maintain air flow, reduce EMI, and protect the system from dust accumulation. Your signals may be connected directly to the I/O boards via custom cabling or take advantage of our wide variety of easy-to-use, external screw terminal panels.

## Dual Retention Thumb Screws

Dual retention thumb screws ensure DNR modules remain in their intended positions. A module ejector tab allows users to remove boards with one hand.

## Passive Backplane

The backplane of the DNR rack contains no active components. This means the DNR chassis offers an almost unlimited MTBF. All active components (except cooling fans) are on easily replaced boards.



## Flexible Mounting

The DNR-Bracket kit allows the rack to be mounted on any flat wall or surface or in a standard 19" rack (requires 3U spacing). The DNR-EXT-BRACKET-4 provides an additional four inches of space between the front of the RACKtangle and the front of your 19" rack, allowing you to keep all your field wiring within the 19" rack space. The 6-slot DNR-6-1G rack includes industrial quality rubber feet for table-top applications.

## CPU and NIC Module

The DNR series CPU/NIC interface is provided in the center slot. This configuration maximizes system noise immunity by reducing the distance an I/O board may be from the CPU. In addition to providing the CPU, this module provides the two Network/Ethernet ports which default to independent Control/Diagnostic ports, but may be teamed/bonded as redundant ports. This module also provides two USB 2.0 ports, the serial configuration port, the recessed reset button, the inter-rack sync interface and the SD card slot.

## Backplane Buffer Module

The DNR-Buffer module provides the interface between the CPU and the various I/O boards. Placing the drive circuitry on a removable board rather than on the backplane ensures the backplane remains totally passive and that all active electronic circuitry is quickly and easily replaceable.

# DNR HalfRACK™

Like the full-size RACKtangle, the DNR-6-1G HalfRACK is a compact (3U), rugged Ethernet I/O rack. The DNR series provides two Gigabit Ethernet interfaces and slots for 6 I/O boards. The front-loading configuration allows the I/O boards to be quickly and easily installed into and removed from the rack. These capabilities dramatically increase performance and simplify system reconfiguration. The backplane within the rack contains no active electronic components, ensuring the rack itself has an almost unlimited MTBF. It also means all active components are on easily replaceable I/O modules, offering an extremely short MTTR in critical applications.



The DNR-6-1G HalfRACK is functionally identical to the full-size RACKtangle, the only difference being half the overall I/O capacity.



## Status LEDs

LEDs display the status of internally monitored parameters including: Internal temperature, system self-test status, bus activity, SD card activity and provide confirmation that required CPU/NIC power supply voltages are within specifications. The USR LED is controlled by the application program allowing a service technician to confirm he/she is working on the correct rack in multiple rack installations.

## Sync Connector

High-speed chassis to chassis synchronization connector. This connector allows triggers or clocks to be shared among racks. Two racks may be connected together directly or larger systems may take advantage of the DNA-SYNC-1G interface to share timing signals among many racks.

## SD Card Slot

Secure Digital (SD) card slot for onboard data storage. The SD card is used as the data storage media in the UEILogger series. It also stores both data and Linux embedded programs deployed on the rack using the soon to be released embedded toolkit. Supports FAT12, FAT16 and FAT32 file systems.

## Serial Port

The serial port is used primarily for system setup and configuration. The rack may be configured from any serial terminal running at 57,600 baud/8 data bits/no parity/1 stop bit. From a terminal program you can, for instance, change the IP address from the default. You also download updated firmware through the serial port. The serial port is usable for RS-232 communications. For users without a convenient serial port, a USB to serial converter provides a simple and inexpensive interface.

## Reset Button

Recessed to prevent accidental activation, this button resets the CPU layer for activities such as downloading and installing new firmware for the DNR rack. It may also be used to start/stop logging when the rack is configured as a UEILogger 1200R.

## Network Connectors

Each NIC interface includes two independent Gigabit Ethernet ports. The 1000Base-T interface allows the rack to be installed up to 100 Meters from your host PC. The two Ethernet ports default to a configuration where one is the control port and the other a diagnostic port. However, they can be teamed/bonded to provide a redundant network interface.

## USB 2.0

The DNR-12-1G and DNR-6-1G provide two high speed USB 2.0 interfaces. One of the USB ports is configured as a controller while the other is configured as a slave port. (Available in UEISIM and UEIPAC configurations)

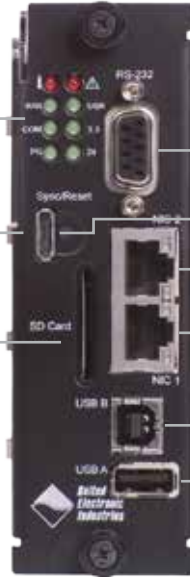

Powerful diagnostics software (shown above) can monitor all system power supplies, temperatures and fan operations.

## Power Supply Annunciator LEDs:

Spec:	ON / OFF	LEDs	Spec:	ON / OFF
<b>Vin</b>	OK / Error		<b>Input I</b>	OK / Overcurrent
<b>1.5V</b>	OK / Error		<b>Fans</b>	On / Off
User controlled (default is off)			One flash per second heartbeat	
<b>Temp</b>	Over / OK		<b>System</b>	Error / OK
<b>24 V*</b>	OK / Error		<b>24 V†</b>	OK / Error
<b>3.3 V*</b>	OK / Error		<b>3.3 V†</b>	OK / Error

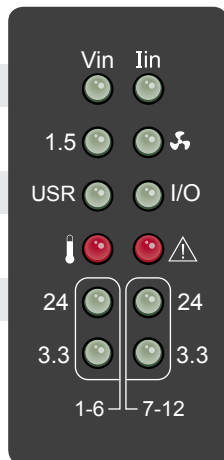

\*24 V & 3.3 V for slots 1-6 on the RACKtangle, and 4-6 on the HalfRACK  
†24 V & 3.3 V for slots 7-12 on the RACKtangle and 1-3 on the HalfRACK

## CPU/NIC Pinouts:

### Power In<sup>1</sup> (Molex)

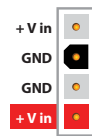

### Serial (RS-232)

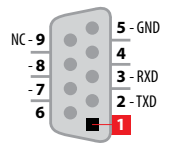

<sup>1</sup> Mating connector available from Digikey, Molex PN 39-01-4040. Please note the female insert pins are sold separately.

### Synchronization<sup>2</sup>

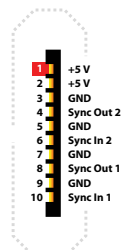

# DNF-4-1G FLATRACK Layout

## 1U Rack Mounting

The compact 1U FLATRACK™ form factor provides a low-profile footprint for space-constrained applications. Rubber feet are also included for tabletop use.

## Protected On/Off Switch

The On/Off switch is mounted within two metal shields that ensure the switch will not be inadvertently turned on or off.

## I/O Slots

The FLATRACK provides four I/O slots. All combinations of DNR-series I/O boards are allowed offering literally millions of possible configurations. DNR series I/O boards are fully plug-and-play. There is no hardware configuration required. Empty slots are covered with blank panels to maintain air flow, reduce EMI, and protect the system from dust accumulation. Your signals may be connected directly to the I/O boards via your custom cabling or take advantage of our wide variety of easy-to-use, external screw terminal panels.

## Dual Retention Thumb Screws

Dual retention thumb screws ensure DNR modules remain in their intended positions. A module ejector tab allows users to remove boards with one hand.



## CPU and NIC Module

The DNR series controller and NIC interface are provided in the left slot. In addition to providing the CPU, this module provides the two Network/Ethernet ports, two USB 2.0 ports, the serial configuration port, the recessed reset button, the inter-rack sync interface and the SD card slot. The two Ethernet ports default to a configuration where one is the control port and the other a diagnostic port. However, they can be teamed/bonded to provide a redundant network interface.

## Serial Port

The serial port is used primarily for system set up and configuration. The rack may be configured from any serial terminal running at 57,600 baud/8 data bits/no parity/1 stop bit. From a terminal program you can, for instance, change the IP address from the default. You also download updated firmware through the serial port. The serial port is usable for RS-232 communications. For users without a convenient serial port, a USB to serial converter provides a simple and inexpensive interface.

## Network Connectors

Each NIC interface includes two independent Gigabit Ethernet ports. The 1000Base-T interface allows the rack to be installed up to 100 Meters from your host PC.

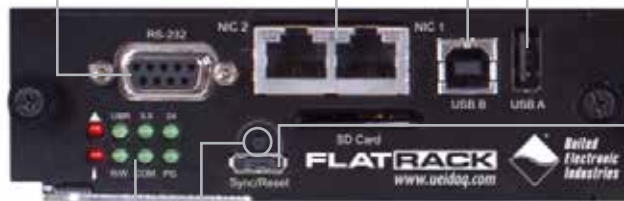

## Passive Backplane

The backplane of the DNR rack contains no active components. This means the DNR chassis offers an almost unlimited MTBF. All active components (except cooling fans) are on easily replaced boards.



## USB 2.0

The DNR-12-1G provides two high speed USB 2.0 interfaces. One of the USB ports is configured as a controller while the other is configured as a slave port. (Available in UEIPAC and UAeISIM configurations only)

## Sync Connector

High-speed chassis to chassis synchronization connector. This connector allows triggers or clocks to be shared among racks. Two racks may be connected together directly or larger systems may take advantage of the DNA-SYNC-1G interface to share timing signals among many racks.

## Status LEDs

LEDs display the status of internally monitored parameters including: Internal temperature, system self-test status, bus activity, SD card activity and provide confirmation that required CPU/NIC power supply voltages are within specifications. The USB LED is controlled by the application program allowing a service technician to confirm he/she is working on the correct rack in multiple rack installations.

## Reset Button

Recessed to prevent accidental activation, this button resets the CPU layer for activities such as downloading and installing new firmware for the DNR rack. It may also be used to start/stop logging when the rack is configured as a UEILogger 1200R. (Contact UEI for availability)

## CPU/NIC Pinouts

### Power In<sup>1</sup> (Molex)



### Serial (RS-232)

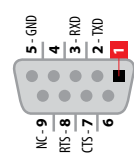

### Synchronization<sup>2</sup>

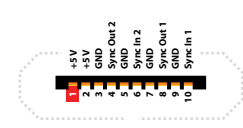

<sup>1</sup>Mating connector available from Digikey, Molex PN 39-01-4040. Please note the female insert pins are sold separately.

<sup>2</sup>GigE cube Sync Pinout

# Cube and RACKtangle I/O Boards



DNA-series boards such as this DNA-AI-207 are used with Cube, DNA-series and UEINet chassis.

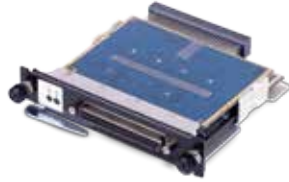

DNR-series boards such as this DNR-QUAD-604 are used with DNR-series RACKtangle chassis.

DNF-series FLATRACKS use DNF-series boards such as this DNF-1553-553.



## I/O Overview

UEI currently offers over 60 different I/O boards for its Cube and RACK I/O chassis. The RACK/Cube versions of the boards are electrically identical and utilize the same printed circuit board, components and software. The difference between the two versions are two-fold. First, the RACK versions of the boards are mounted in RACK compatible mounting brackets while the Cube versions do not require a bracket. Second, the RACK board's primary connector pins run parallel to the PCB, allowing it to be plugged into the RACK backplane. Cube board connectors are mounted perpendicular to the PCB so the board may be stacked within the cube.

From a part number perspective, Cube systems including the DNA-PPCx, DNA-PPCx-1G, DNA-PPCx-1G-MIL and UEINet use DNA-series I/O boards (e.g., DNA-AI-225). RACKtangle-based systems use DNR-series boards (e.g., DNR-AI-225) while the FLATRACK systems use DNF-series boards (e.g., DNF-AI-225).

## Analog Input:

### DNx-AI-201-100 (High Speed, 24-Channel)



- 24 single-ended or 12 differential inputs
- 16-bit resolution,
- $\pm 15, \pm 7.5, \pm 3, \pm 1.5$  V input ranges
- 100 kS/s max sampling rate

### DNx-AI-202 (Current Input)



- 12 current inputs
- 16-bit resolution
- 16 kS/s maximum sampling rate
- Autocalibration
- Input ranges  $\pm 150, \pm 15, \pm 1.5$  mA  
(covers industrial ranges: 0-20 mA and 4-20 mA)

### DNx-AI-204 (0-20 / 4-20 mA input)



- 24 fully differential channels
- Max sampling rate of 250 Hz/CHNL
- 18-bit resolution
- Automatic offset removal

### DNx-AI-205 (High Speed, Simultaneous Sampling)



- 4 fully isolated differential channels
- Max sampling rate of 250 kHz/CHNL
- $\pm 100$  V max input range
- 18-bit resolution
- Overvoltage protection
- Simultaneous sampling
- Polyphase FIR filtering and decimation

### DNx-AI-207 (General Purpose 18-Bit A/D)



- 16 differential analog input channels
- Additional dedicated CJC channel
- Max sampling rate of 1 kHz/channel
- 18-bit resolution;
- 12 input ranges from  $\pm 10$  V to  $\pm 12.5$  V
- Overvoltage protection ( $-40$  to  $+55$  V)
- Dynamic autozero support
- Direct Inputs for thermocouples
- Embedded averaging engine

### DNx-AI-208 (Strain & Bridge Inputs)



- 8 differential channels
- 18-bit resolution
- 1 kS/s per channel max sampling rate
- Supports full-, half- and quarter-bridge configurations
- Built-in shunt calibration
- Provides excitation for bridge

All layers provide 350 Vrms optical isolation (layer-to-layer, layer-to-cube/RACK). Selected layers provide per-channel isolation.

**"DNA" vs "DNR":** The DNA- prefix designates a Cube-compatible board (e.g., DNA-AI-207), while a DNR- / DNF- prefix indicates a RACKtangle / FLATRACK-compatible board. DNA series products are shown in photos except as noted—since the DNA-series boards provide a better view of the circuitry, and the DNR/DNF-series carrier hardware limits the view of the board itself.

## Analog Input:

### DNx-AI-211 (ICP® / IEPE Input)



- 4 input channels
- 24-bit resolution
- 125 kS/s maximum sampling rate
- 100 dB anti-aliasing filter
- Status LEDs show open/short circuits
- Channel to Channel isolation
- 37-pin "D" or coaxial connections
- Includes terminal panel (as shown)

### DNx-AI-212 (Thermocouple Inputs)



(DNR-AI-212 Shown)

- 12 input channels
- 24-bit resolution
- isolation
- Built-in CJC circuitry
- 50, 60 and 400 Hz rejection
- Simultaneous sampling
- One A/D converter per channel
- 1,800 Hz maximum sample rate

### DNx-AI-217 (General Purpose, Simultaneous Sampling 24-bit A/D)



(DNR-AI-217 Shown)

- 16 differential analog input channels
- 24-bit resolution
- 120 kHz (per channel) sample rate (max aggregate board rate is 480 kHz)
- Simultaneous sampling on all chan
- One A/D converter per channel

#### Guardian Features

- Open input detection
- Over-range detection

### Guardian Series Advantages

I/O boards shown on a green background are part of our popular Guardian series. The Guardian series boards provide an extra level of diagnostics and are designed to help you quickly and easily diagnose and correct short circuits, open circuits, over-voltage conditions and many other possible failure conditions. These features are also very useful when used in conjunction with Power On Self Test (POST).

### DNx-AI-218 (Isolated A/D) *New Self-Test Functionality!*



(DNR-AI-218 Shown)

- 8 fully differential inputs
- Simultaneously sampling channels
- One A/D converter per channel
- isolation
- 24-bit resolution filter
- 120 kS/s per channel max sample rate
- Built-in anti-aliasing filters
- ±10 VDC inputs with gains of 1, 2, 4, 8, 16 and 32

### DNx-AI-219 (Low Latency Isolated A/D) **NEW!**



(DNR-AI-219 Shown)

- 8 fully differential inputs
- Simultaneously sampling channels
- One successive approximation A/D converter per channel
- isolation
- 18-bit resolution
- 120 kS/s per channel max sample rate
- ±10 VDC inputs w/ gains of 1 to 32
- Built-in self-test functionality

### DNx-AI-222 (RTD Inputs)



(DNR-AI-222 Shown)

- 12 fully differential channels
- 2, 3 or 4 wire inputs
- 24-bit resolution
- 50, 60 and 400 Hz rejection
- 0.005 °C resolution
- Open channel detection
- 1,800 Hz maximum sample rate
- Simultaneous sampling

### DNx-AI-224 (High-Speed Strain & Bridge)



(DNR-AI-224 Shown)

- 4 differential channels
- 18-bit resolution
- 125 kS/s per channel max sampling rate
- Built-in bridge completion resistors
- Built-in Shunt Calibration
- Programmable bridge excitation voltage

All layers provide 350 Vrms optical isolation (layer-to-layer, layer-to-cube/RACK). Selected layers provide per-channel isolation.

**"DNA" vs "DNR":** The DNA- prefix designates a Cube-compatible board (e.g., DNA-AI-207), while a DNR- / DNF- prefix indicates a RACKtangle / FLATRACK-compatible board. DNA series products are shown in photos except as noted – since the DNA-series boards provide a better view of the circuitry, and the DNR/DNF-series carrier hardware limits the view of the board itself.

### DNx-AI-225 (24-bit Resolution, Simultaneous Sampling)



- 25 differential channels (1 channel can be used for CJC)
- 24-bit resolution
- Simultaneous sampling
- One A/D per channel
- 5 S/s to 1 kS/s sampling rates
- $\pm 1.25$  V referenced differential input range



*New Self-Test Functionality!*  
(DNR-AI-228 Shown)

- 8 input channels
- $\pm 75$  VDC maximum input measurement
- 24-bit resolution
- One A/D converter per channel
- isolation
- 120 kS/s per channel max sample rate
- 

### DNx-AI-228-300 ( $\pm 300$ VDC Isolated A/D)



*New Self-Test Functionality!*  
(DNR-AI-228-300 Shown)

- 8 input channels
- $\pm 300$  VDC maximum input measurement
- 24-bit resolution
- One A/D converter per channel
- isolation
- 120 kS/s per channel max sample rate
- Built-in anti-aliasing filters

### DNx-AI-248-230 (24 channel -2 to 32 V A/D) **NEW!**



- 24 differential channels (plus 1 channel for CJC)
- 18-bit resolution
- -2 VDC to +32 VDC input ranges
- Gains of 1 to 1000
- Automatic offset removal
- Embedded averaging engine

## LVDT/RVDT/Synchro/Resolver:

### DNx-AI-254 (LVDT / RVDT Input Board)

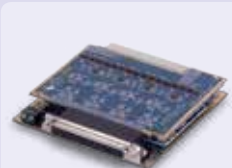

- 4 LVDT/RVDT inputs or simulated outputs
- 16-bit resolution
- 3 and 4 wire configurations
- 2 to 7 Vrms programmable excitation
- 100 Hz to 5 kHz excitation frequency
- 50 mA excitation current (max)
- Channel to channel isolation
- Functions as a measurement I/O device or simulates LVDT/RVDT outputs

### DNx-AI-255 (Synchro/Resolver Board)



(DNR-AI-255 Shown)

- 2 channels input or simulated output
- 16-bit resolution
- 3-wire (Synchro) or 4-wire (resolver) inputs
- 2 to 28 Vrms programmable reference
- 50 Hz to 4 kHz reference
- Channel to channel isolation
- Functions as a measurement device or simulates Synchro/resolver outputs

### DNx-AI-256 (High Drive Synchro/Resolver/RVDT/LVDT)



- 2 input or simulated outputs
- Up to 2.4 VA output/reference drive
- 50 Hz to 10 kHz frequency range
- isolation
- Includes fan board for high output (mounts in adjacent slot)

(DNR-AI-256 Shown)

## Special and Harsh Environments

All of our Cubes and RACKS are rugged and suitable for use in tough environments including tested in altitudes as high as 120,000 feet (requires special preparation), Radiation tested for space applications and Simulated rain testing.

However, if you need something more rugged still, we have the ideal solution in our MIL series Cubes and RACKS. Please review pages 30-32 for an overview on the MIL series chassis.

All layers provide 350 Vrms optical isolation (layer-to-layer, layer-to-cube/RACK). Selected layers provide per-channel isolation.

**“DNA” vs “DNR”:** The DNA- prefix designates a Cube-compatible board (e.g., DNA-AI-207), while a DNR- / DNF- prefix indicates a RACKangle / FLATRACK-compatible board. DNA series products are shown in photos except as noted – since the DNA-series boards provide a better view of the circuitry, and the DNR/DNF-series carrier hardware limits the view of the board itself.

## Analog Output:

### DNx-AO-308 (8 channel D/A Board)



- 8 independent DACs
- 16-bit resolution
- 100 kHz per channel max update rate
- $\pm 10$  V output,  $\pm 5$  mA outputs
- Low glitch outputs
- Per-channel offset and gain calibration
- Simultaneous update across all channels

### DNx-AO-308-350 (High Current D/A Board)



- $\pm 10$  V output,  $\pm 50$  mA
- 8 independent DACs
- 16-bit resolution
- 100 kHz per channel max update rate
- Output sense lines provided
- Low glitch outputs
- Per-channel offset and gain calibration
- Simultaneous update across all channels

### DNx-AO-308-352 ( $\pm 13.5$ VDC Analog Outputs)



- 8 analog output channels
- $\pm 13.5$  VDC at 13.5 mA outputs
- Simultaneous output updates
- 100 kHz max update rate

### DNx-AO-308-353 (High Voltage D/A Board)



- $\pm 40$  V,  $\pm 5$  mA outputs
- 8 independent DACs
- 16-bit resolution
- 100 kHz per channel max update rate
- Low glitch outputs
- Simultaneous update across all channels
- Requires external  $\pm 45$  V power supply

### DNx-AO-308-420 (4-20 mA Output D/A Board)



- Standard 4-20 mA outputs
- 8 independent DACs
- 16-bit resolution
- 100 kHz per channel max update rate
- Low glitch outputs
- Per-channel offset and gain calibration
- Simultaneous update across all channels
- 0 - 20 mA version available

### 10-Year Availability Guarantee!



UEI guarantees the hardware you purchase today will still be available 10 years from now!

Visit our site to learn more!

### DNx-AO-318 (Isolated 8-Ch D/A Board with Read-back)



(DNR-AO-318 Shown)

- 8 independent DACs
- Channel to channel isolation
- 10 kHz per channel max update rate
- $\pm 10$  V,  $\pm 10$  mA outputs

#### Guardian Features

- Voltage and current read-back capability on all outputs
- Redundent output D/As

**NEW!**

### DNx-AO-318-020 (Isolated 8-Ch 0-20mA D/A with Read-back)



(DNR-AO-318-020 Shown)

- 8 independent DACs
- Channel to channel isolation
- 10 kHz per channel max update rate
- 0-20 mA / 4-20 mA outputs

#### Guardian Features

- Voltage and current read-back capability on all outputs
- Overcurrent circuit breaker

**NEW!**

All layers provide 350 Vrms optical isolation (layer-to-layer, layer-to-cube/RACK). Selected layers provide per-channel isolation.

**“DNA” vs “DNR”:** The DNA- prefix designates a Cube-compatible board (e.g., DNA-AI-207), while a DNR- / DNF- prefix indicates a RACKangle / FLATRACK-compatible board. DNA series products are shown in photos except as noted—since the DNA-series boards provide a better view of the circuitry, and the DNR/DNF-series carrier hardware limits the view of the board itself.

## Analog Output: (Continued)

### DNx-AO-332 (32 Channel D/A Board)



- 32 independent DACs
- 16-bit resolution
- 10 kHz per channel max update rate
- $\pm 10$  V,  $\pm 10$  mA outputs
- Low glitch outputs
- Simultaneous update across all channels

### DNx-AO-333 (32 Channel D/A Board with Read-back)



(DNR-AO-333 Shown)

- 32 independent DACs
- 16-bit resolution
- 10 kHz per channel max update rate
- $\pm 10$  V,  $\pm 10$  mA outputs

#### Guardian Features

- On-board A/D converter provides read-back capability on all outputs

### DNx-AO-358 (Variable Res / Strain Gauge Simulator)



(DNR-AO-358 Shown)

- 8 output channels
- Built-in strain gauge completion resistors
- 120, 350 or 1 k Ohm versions
- As low as .46 mOhm resolution

### DNx-AO-364 (Function Generator / AWFG)



(DNR-AO-364 Shown)

**NEW!**

- 4 independent channels
- Sine, Square, Triangle or AWFG
- 150 kHz max output rate
- Frequency sweep
- Programmable inter-channel phase shift
- 0-8.5 Vrms output range
- 0.25 Hz freq resolution

### PD-AO-AMP 115 ( $\pm 115$ VDC Analog Output Buffer Amp)



- 16 channels of high voltage analog out
- Up to 115 VDC at  $\pm 10$  mA
- Pinout compatible with AO-308 series
- 0.01% gain error
- Low glitch outputs
- Simultaneous update across channels
- Ideal for driving a wide variety of devices including piezo electric controllers
- Requires PSU-AO32G115 power supply or user supplied  $\pm 125$  VDC supply

### UEI-STP-AO-200 (250 mA Analog Output Buffer Amp)



- 8 channels of high current analog output
- Up to  $\pm 250$  mA output at  $\pm 10$  V
- Pinout compatible with AO-308 series
- Low glitch outputs
- Simultaneous update across all channels

## System Burn-In

All DNA- and DNR-series are fully burned-in for a minimum of 12 hours prior to shipment. Our burn-in is much more than simply applying power and looking for smoke. We test all input and outputs constantly during the burn-in process. We also cycle power on and off every 2-3 minutes during the burn-in process.



All layers provide 350 Vrms optical isolation (layer-to-layer, layer-to-cube/RACK). Selected layers provide per-channel isolation.

**“DNA” vs “DNR”:** The DNA- prefix designates a Cube-compatible board (e.g., DNA-AI-207), while a DNR- / DNF- prefix indicates a RACKtangle / FLATRACK-compatible board. DNA series products are shown in photos except as noted—since the DNA-series boards provide a better view of the circuitry, and the DNR/DNF-series carrier hardware limits the view of the board itself.

## Digital I/O:

### DNx-DIO-401 (24-Bit Digital Input)



- 24 Digital Input bits
- 5 - 36 V input levels
- Programmable hysteresis
- 1024 sample FIFO
- 1 k samples/sec throughput rate
- Triggering available on digital inputs

### DNx-DIO-402 (24-Bit Digital Output)



- 24 Digital Outputs
- High-side (source) Darlington outputs
- Up to 36 V on input/output channels
- 1024 sample FIFO
- 1 k samples/sec throughput rate
- 80 mA/channel output drive
- 100 mA resettable PTC fuse

### DNx-DIO-403 (48 Bit Logic-Level I/O)



- 48 TTL-compatible digital I/O
- I/O throughput rate of 10 kHz
- 16 mA/channel output drive
- Lines protected up to 7 kV electrostatic discharge
- Triggering available on digital inputs

### Reflective Memory / ScramNet Replacement

UEI's Cubes and RACKs are ideal replacements for aging systems using reflective memory or ScramNet. Our DMAP/VMAP Ethernet protocols ensure real-time transfer of the I/O data between the RACK and your host without special RM/SN hardware. If you also require host-to-host data sharing, we recommend a DDS. The DDS allows data sharing among PCs over a standard Ethernet link and don't require expensive, dedicated Reflective Memory hardware. We have tested our systems with PrismTech's OpenSplice™ and RTI Connex™ DDS packages.

### DNx-DIO-404 (24-Bit DIO, FET Outputs)



- 12 Din, 12 Dout
- High-side (source) FET outputs
- 350 mA outputs (continuous)
- 500 mA resettable PTC fuse
- 3.3 - 36 VDC input range
- User-programmable hysteresis
- 100 kS/sec throughput

### DNx-DIO-405 (24-Bit DIO, Darlington Outputs)



- 12 Din, 12 Dout
- High-side (source) Darlington outputs
- 80 mA outputs (continuous)
- 100 mA resettable PTC fuse
- 3.3 - 36 VDC input range
- User-programmable hysteresis
- 1 kS/sec throughput

### DNx-DIO-406 (24-Bit DIO, FET Outputs)



- 12 Din, 12 Dout
- Low-side (sink) FET outputs
- 1 A outputs (continuous)
- 2 A slow-blow fuse
- 3.3 - 36 VDC input range
- User-programmable hysteresis
- 100 kS/sec throughputs

### Guardian Series Advantages

I/O boards shown on a green background are part of our popular Guardian series. The Guardian series boards provide an extra level of diagnostics and are designed to help you quickly and easily diagnose and correct short circuits, open circuits, over-voltage conditions and many other possible failure conditions. These features are also very useful when used in conjunction with Power On Self Test (POST).

All layers provide 350 Vrms optical isolation (layer-to-layer, layer-to-cube/RACK). Selected layers provide per-channel isolation.

**"DNA" vs "DNR":** The DNA- prefix designates a Cube-compatible board (e.g., DNA-AI-207), while a DNR- / DNF- prefix indicates a RACKtangle / FLATRACK-compatible board. DNA series products are shown in photos except as noted—since the DNA-series boards provide a better view of the circuitry, and the DNR/DNF-series carrier hardware limits the view of the board itself.



## Digital I/O:

### DNx-DIO-432 (32-Bit [sink] DOUT Board *with Readback*)

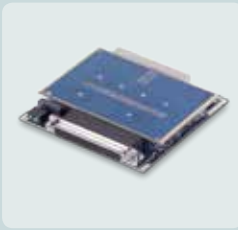

- 32 Industrial digital outputs
- Programmable overcurrent protection
- 3-36 VDC operation
- 600 mA continuous (sink) outputs
- 1 kHz update rate

#### **Guardian Features**

- Built-in monitoring of output voltage and current detects shorts/opens
- PWM output and soft-start mode

### DNx-DIO-432-800 (Low Leakage Current DIO-432)

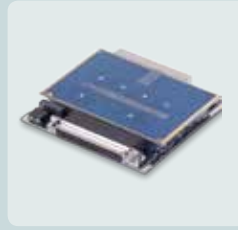

- 32 Industrial digital outputs
- <1  $\mu$ A leakage ensures LEDs appear off even when viewed through NV goggles
- Programmable overcurrent protection
- 600 mA continuous (sink) outputs
- 1 kHz update rate

#### **Guardian Features**

- Built-in monitoring of output current
- PWM output and soft-start mode

### DNx-DIO-433 (32-Bit [source] DOUT Board *with Readback*)



(DNR-DIO-433 Shown)

- 32 Industrial digital outputs
- Programmable overcurrent protection
- 3-36 VDC operation
- 600 mA continuous (sink) outputs
- 1 kHz update rate

#### **Guardian Features**

- Built-in monitoring of output voltage and current detects shorts/opens
- PWM output and soft-start mode

### DNx-DIO-433-800 (Low Leakage Current DIO-433)



(DNR-DIO-433 Shown)

- 32 Industrial digital outputs
- <1  $\mu$ A leakage ensures LEDs appear off even when viewed through NV goggles
- Programmable overcurrent protection
- 600 mA continuous (sink) outputs
- 1 kHz update rate

#### **Guardian Features**

- Built-in monitoring of output current
- PWM output and soft-start mode

### DNx-DIO-441 (Dual 20 x 2 Channel Multiplexer)



(DNR-DIO-441 Shown)

- Dual 20 x 2 configuration. (Two channels where any of 20 inputs can be connected to either of two common signals.)
- $\pm$  45 VDC operation
- < 1  $\Omega$  on resistance
- < 8 nA leakage current
- 600 mA max continuous current

### DNx-DIO-448 (48-bit Digital Input Board with A/D)



(DNR-DIO-448 Shown)

- 48 digital inputs
- Programmable on/off levels and hysteresis (0 - 28 VDC)
- 1 kHz scan rate
- Built-in pull-up/down resistors

#### **Guardian Features**

- Built-in A/D converter allows actual input voltage to be measured

### DNx-DIO-449 (48-bit Digital Input Board with A/D)



(DNR-DIO-448 Shown)

- 48 digital inputs
- Programmable on/off levels and hysteresis ( $\pm$  150 VDC, - 150 VAC)
- 1 kHz scan rate
- Built-in pull-up/down resistors
- Automatic change-of-state detection

#### **Guardian Features**

- Built-in A/D converter allows actual input voltage to be measured

### DNx-DIO-452 (Relay Output Board)



- DIO-452: 12 Form C (SPDT) relays
- 2.0 A output at 30 VDC (continuous)
- 750 mA at 120 VAC (continuous)
- $\pm$ 500 VDC isolation
- Solid-state relays available
- Guardian series with readback available, (see DIO-462)

All layers provide 350 Vrms optical isolation (layer-to-layer, layer-to-cube/RACK). Selected layers provide per-channel isolation.

**“DNA” vs “DNR”:** The DNA- prefix designates a Cube-compatible board (e.g., DNA-AI-207), while a DNR- / DNF- prefix indicates a RACKtangle / FLATRACK-compatible board. DNA series products are shown in photos except as noted—since the DNA-series boards provide a better view of the circuitry, and the DNR/DNF-series carrier hardware limits the view of the board itself.

## Relay Outputs:

### DNx-DIO-462 (12 Form C Relays with V/I Readback)



- 12 Form C (SPDT) relays
- 2.0 A output at 30 VDC (continuous)
- 750 mA at 120 VAC (continuous)
- $\pm 500$  VDC isolation
- Solid-state relays available as option

#### Guardian Features

- Output current readback
- Output voltage readback

### DNx-DIO-463 (12 Solid State Relays with V/I Readback)



- 12 Form A (SPST) solid state relays
- 2.0 A output at 48 VDC (continuous)
- 2.0 A output at 35 VAC (continuous)
- 150 mOhm on resistance
- $\pm 350$  VDC isolation

**NEW!**

#### Guardian Features

- Output current readback
- Output voltage readback

## Serial I/O (Asynchronous):

### DNx-DIO-470 (High Current Relay Outputs)



- 10 Form C (SPDT) relays
- 5 Amp @ 125 VAC or 30 VDC continuous loads
- 140 VDC / 150 VAC max operating voltage
- Uses special high current cables for 5 Amp operation

### DNx-SL-501 (4 RS-232/422/485 Ports)

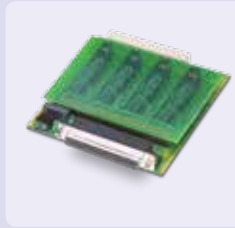

- 4 independent ports
- Each port is software-configurable as RS-232, RS-422 or RS-485
- Max speed of 256 kbit/s for RS-232 and up to 4 Mbit/s for RS-422/485
- Independent bit rate settings for each port
- 350 V isolation between ports; ports and circuitry; 15 kV ESD

## Serial I/O (Synchronous):

### DNx-SL-508 (8 RS-232/422/485 Ports)



- 8 independent ports
- Each port is software-configurable as RS-232, RS-422 or RS-485
- Max speed of 256 kbit/s for RS-232 and 1 Mbit/s for RS-422/485
- Independent bit rate and protocol settings for each port
- 350 V isolation
- Built-in interrogation scheduler

### DNx-SL-504 (4-Port Synchronous Serial Interface)



(DNR-SL-504 Shown)

- 4 independently configurable ports
- Max speed of 256 Kbaud for RS-232 and 4 Mbaud for RS-485/422
- Async, bisync, HDLC, SDLC protocol support
- 350 Vrms port-to-port isolation;
- 15kV ESD

## Remote Serial Server Software:

### UEI-RSS (Remote Serial Server)



- Supports DNx-SL-series
- SL-50x ports become standard PC "COM" ports
- Standard COM1: to COM255: in Windows XP/Vista/7 (32- and 64-bit)
- Standard POSIX ports in Linux
- Supported by PowerDNA and UEIPAC

## CAN-Bus and ARINC 825:

### DNx-CAN-503 (High-Speed CAN-Bus)

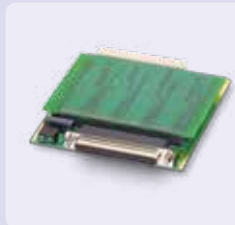

- 4 independent CAN ports
- Up to 1 Mbit/sec max transfer rate
- Independent bit rate settings for every port
- 250 V DC max isolation between ports; ports and circuitry
- Hot plugging support; error detection
- Fully compatible with ISO 11898
- J1939 and CANdb support

All layers provide 350 Vrms optical isolation (layer-to-layer, layer-to-cube/RACK). Selected layers provide per-channel isolation.

**"DNA" vs "DNR":** The DNA- prefix designates a Cube-compatible board (e.g., DNA-AI-207), while a DNR- / DNF- prefix indicates a RACKangle / FLATRACK-compatible board. DNA series products are shown in photos except as noted—since the DNA-series boards provide a better view of the circuitry, and the DNR/DNF-series carrier hardware limits the view of the board itself.

## Avionics: ARINC and AFDX®

### DNx-429-566 (12 ARINC-429 Channels)



- 6 TX/6 RX channels
- High (100 kHz) or low (12.5 kHz) speed selectable by channel pairs
- Hardware Label filtering
- Hardware TX scheduler (100 μs timing resolution)
- Automatic timestamping of RX data
- Williamsburg (Version 1) protocol support included

### DNx-429-512 (12 ARINC-429 Rx Channels)



- 12 ARINC-429 RX channels
- High (100 kHz) or low (12.5 kHz) speed selectable by channel pairs
- Hardware Label filtering
- Automatic timestamping of RX data (if desired)
- Williamsburg (Version 1) support included

### DNx-708-453 (4 ARINC-708/453 Channels)



(DNR-708-453 Shown)

- 2 Transmit outputs
- 2 Receive inputs
- ARINC-708 and ARINC-453 compatible
- Includes coaxial cable adaptor

### DNx-AFDX-664 (2-Port AFDX®/ARINC 664 Interface)



- 2-ports AFDX®/ARINC 664
- Dual redundant or independent port modes
- 100 Mbit/s or 10 Mbit/s
- Error detection and injection
- Supports Airbus and Boeing protocols

**NEW!**

## Avionics: MIL-STD-1553

### DNx-1553-553 (Dual Redundant 1553 Interface)



- Two independent, fully redundant channels
- Bus Monitor, Remote Terminal and Bus controller functionality
- Selective message monitoring in Bus Monitor mode.
- Transformer or direct coupling
- Multiple RT simulation up to 31 RTs.
- Includes cable to std 1553 connectors

## Avionics to Ethernet Bridge

### UEINet (please see pages 22-25) **NEW!**



- Extremely compact (2.7" x 4.1" x 4.0")
- Supports 1553, AFDX, ARINC 429/708/453
- Dual Gigabit Ethernet ports
- Includes software
- AC or DC powered
- Software compatible with all UEI's Cube and RACKtangle chassis

## Counter / Timer

### DNx-CT-601 (Counter/Timer)



- 8 independent counter/timer units; start/pause/stop all channels simultaneously
- 32-bit prescaler per channel
- Multiple period counter with accumulated results
- Debouncing/glitch removal on external clock and gate inputs
- 8 counting modes

### DNx-CT-602 (Differential Counter/Timers)



- 4 independent 32-bit counters w/ 32-bit prescalers
- 66 MHz internal time base
- 16.5 MHz max external frequency
- Standard RS-485 fully differential logic levels
- 8 powerful counting modes
- Built-in debouncing and glitch removal

All layers provide 350 Vrms optical isolation (layer-to-layer, layer-to-cube/RACK). Selected layers provide per-channel isolation.

**“DNA” vs “DNR”:** The DNA- prefix designates a Cube-compatible board (e.g., DNA-AI-207), while a DNR- / DNF- prefix indicates a RACKtangle / FLATRACK-compatible board. DNA series products are shown in photos except as noted—since the DNA-series boards provide a better view of the circuitry, and the DNR/DNF-series carrier hardware limits the view of the board itself.

## Serial I/O (Synchronous):

### DNx-CT-602-804 (Synchronous Serial Ports)



- 4 independent channels
- Channels configure as serial ports or counter/timers
- Programmable data word & frame synch length
- RS-485/422 logic levels

## Quadrature Encoder Input

### DNx-QUAD-604 (Quadrature Encoder Input)

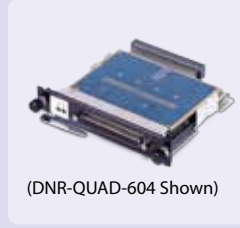

(DNR-QUAD-604 Shown)

- 4 Independent quadrature encoder inputs
- A, B, and Z index inputs
- Buffered or single point readings
- Simultaneous updates on all four channels
- Debouncing / Glitch removal
- 8 Dout, 4 Din aux DIO bits

## Variable Reluctance RPM Input

### DNx-VR-608 (Variable Reluctance Input)



- 8 channels of VR input
- Wide input range (50 mV to 250 V p-p)
- 50 kHz maximum pulse rate
- Inter-tooth timing measurement allows acceleration tracking
- True zero cross detection inputs
- Key/Golden tooth detection

## IRIG-A, B, E, G, GPS and high precision timing:

### DNx-IRIG-650 (IRIG-A, B, E, G Timing Gen and Sync boards)



(DNR-IRIG-650 Shown)

- IRIG-B output for timing signals
- IRIG-B input for sync with external IRIG-B sources
- Modulated or DC level I/O
- 1 PPS output
- Event input captures timing to UTC
- On-board GPS receiver
- 10 MHz, 1 ppm time base or slaved to external 10 MHz

## GPS:

### DNA-GPS (GPS Receiver System)



- Based on Garmin GPS 16 series
- < 3 meter error (using WAAS)
- Simple connection to DNA-SL-501 serial interface layer
- 1 PPS synched to UTC within 1  $\mu$ S
- Includes DNA-STP-GPS break-out panel
- Compatible with all popular NMEA protocols

## Wireless:

### DNA-CAR-550 (PCI-Express Mini Card Module Reader)



- For UEIPAC series Cubes
- Allows UEIPAC direct connection to CELL/WIFI networks
- Allows UEIPAC direct connection to GPS antennas
- Supports CELL/WIFI/GPS cards from many vendors
- Standard Mini Card USB interface

## Power Conversion:

### DNx-PC-911/912/913 (Power Supply Output boards)



(DNR-PC-911 Shown)

- $\pm 15V$  @1.2A (911); +24V @1.6A (912);  $\pm 45V$  @0.4A (913)
- Available for Cubes and RACKs
- Isolated DC/DC converters
- Overload protection
- Overtemperature shutdown
- Software-controlled On/Off switch
- Readback of output voltage and current

## 10-Year Availability Guarantee!



UEI guarantees the hardware you purchase today will still be available 10 years from now!

Visit our site to learn more!

# I/O Quick Reference Guide

## Analog Input (200 Series)

Board Type	Part Number (DNx-)	Number of Channels	Resolution (Bits)	Maximum Sample Rate (Channel) kS/sec	Maximum Sample Rate (Board) kS/sec	Simultaneous Sampling (no MUX)	Maximum Input Range	Minimum Input Range	Channel-to-Channel Isolation	MTBF
High Density, Low Cost	AI-201-100	24SE/12DI	16	100	100	-	±15 V	±1.5 V	-	>600,000
High Density	AI-248-230	24 DI	18	0.25	6	-	+32/-2 V	+32/-2 mV	-	500,000
High Speed, Simultaneous Sampling	AI-217	16 DI	24	120	480	✓	±10 V	±156 mV	-	275,000
High Speed, Fully isolated	AI-218	8 DI	24t	120	480	✓	±10 V	±156 mV	✓	200,000
High Speed, High Voltage	AI-205	4 DI	18	250	1000	✓	±100 V	±100 mV	✓	>600,000
High Voltage, Fully Isolated	AI-228-300	8 DI	24	120	480	✓	±300 V	±37.5 V	✓	200,000
Medium Voltage, Fully isolated	AI-228	8 DI	24	120	480	✓	±75 V	±9.38 V	✓	200,000
General Purpose, Low noise	AI-207	16 DI	18	16	16	-	±10 V	±12.5 mV	-	>600,000
Thermocouple Input	AI-212	12 DI	24	0.100	1.2	✓	±2.048 V	±32 mV	✓	230,000
Thermocouple Input, Low Voltage, High Resolution, High Density,	AI-225	25 DI	24	1	25	✓	±1.25 V	-	-	520,000
RTD / Resistance	AI-222	12 DI	24	0.150	1.8	✓	40k ohm	100 ohm	✓	230,000
Strain/Bridge input low cost	AI-208	8 DI	18	8	8	-	±10 V	±12.5 mV	-	>600,000
Strain/Bridge input, high performance	AI-224	4 DI	18	100	400	✓	±20 V	±78 mV	✓	260,000
ICP / IEPE Accelerometers	AI-211	4 DI	24	125	500	✓	+25 / -13 V	±2.5V	✓	250,000
Current input	AI-202	12 DI	16	16	16	-	±150 mA	±1.5 mA	-	>600,000
0-20 / 4-20 mA input	AI-204	24 DI	18	0.25	6	-	20 mA	-	-	>500,000
LVDT / RVDT	AI-254	4 DI	16	5	20	✓	±39.6 V	-	✓	275,000
Syncho / Resolver	AI-255	2 DI	16	4	8	✓	±39.6 V	-	✓	275,000
Syncho / Resolver & RVDT/LVDT, High Drive	AI-256	2 DI	16	10	20	✓	±39.6 V	-	✓	275,000

Guardian Series—Includes a variety of powerful diagnostic and BIT functionality.

# I/O Quick Reference Guide

## Analog Output (300 Series)

Board Type	Part Number (DNx-)	Number of Channels	Resolution (Bits)	Update Rate (Channel) kS/sec	Update Rate (Board) kS/sec	Output Range (Volts)	Output Current Drive (mA)	Channel-to-Channel isolation	MBTF
General Purpose	A0-308	8	16	100	500	+/-10	+/-5	-	480,000
Fully Isolated with readback	A0-318	8	16	10	80	+/-10	+/-10	✓	200,000
High Current	A0-308-350	8	16	100	500	+/-10	+/-50	-	480,000
High Density	A0-332	32	16	10	320	+/-10	+/-10	-	400000
High Density with readback	A0-333	32	16	10	320	+/-10	+/-10	-	400000
Medium Voltage/Current	A0-308-352	8	16	100	500	+/-12.5	+/-12.5	-	480,000
High Voltage	A0-308-353	8	16	100	500	+/-40	+/-5	-	480,000
Current Output (0-20mA)	A0-308-020	8	16	100	500	-	0-20mA	-	200,000
Current Output (0-20mA), isolated with readback	A0-318-020	8	16	10	80	-	0-20mA	✓	200,000
Current Output (4-20mA)	A0-308-420	8	16	100	500	-	4-20mA	-	480,000
High Current Buffer (external)	DNA-STP-A0-200	8	-	-	-	+/-10	0-250mA	-	200,000
High Voltage Amplifier (external)	PD-A0-AMP-115	16	-	-	-	+/-115	+/-10	-	200,000
<b>FUNCTION GENERATOR/AWFG</b>									
Function / Arbitrary Waveform Generator	A0-364	4	16	150 (D/A @ up to 16.5 MHz)	600	+/-12	+/-10mA	✓	290,000
<b>SIMULATED DEVICE/SENSOR</b>									
Strain Gage Simulator, 120/350/1k Ohm	A0-358-120/350 or 1k	8 Bridges	0.46/1.33 3.82 mΩ	5	40	N/A	N/A	✓	250,000
Strain/resistance simulator, special range	A0-358-xxx	8 Outputs/Bridges	18	5	40	N/A	N/A	✓	300,000
Simulated LVDT / RVDT	AI-254	4	16	5 kHz exc		0 - 6.7 Vrms	65 mA	✓	275,000
Simulated Synchro / Resolver	AI-255	2	16	4 kHz exc		0 - 28 Vrms	1.2 VA	✓	275,000
Simulated S / R & RVDT/LVDT, High Drive	AI-256	2	16	10 k Hz exc		0 - 19.8 Vrms	2.4 VA	✓	275,000

Guardian Series—Includes a variety of powerful diagnostic and BIT functionality.

## Digital I/O (400 Series)

Board Type	Part Number (DNx-)	Number of Channels	Input (kHz)	Output (kS/s)	Drive Capacity	Range (min V)	Range (max V)	Accessories	PWM	MTBF
<b>DISCRETE I/O</b>										
Logic Level	DIO-403	48	10	20	16 mA	3.3	5	DNA-STP-403	-	>600,000
Sourcing Outputs, 3.3-36VDC Inputs	DIO-404	12 in/12out	100	100	350 mA continuous 500mA peak	3.3	36	DNA-PC-912	-	375,000
Sourcing Darlington Outputs, 5-36VDC Inputs	DIO-405	12 in/12out	1	1	80 mA continuous/ 200mA peak	5	36	DNA-PC-912	-	>600,000
Sinking Outputs, 3.3-36VDC Inputs	DIO-406	12 in/12out	100	100	1 A continuous/ 1.5A peak	3.3	36	DNA-PC-912	-	375,000
<b>DISCRETE INPUTS</b>										
5-36 V DC Inputs	DIO-401	24	1	-	-	5	36	DNA-PC-912	-	>600,000
0-32 V DC Inputs	DIO-448	48	1	-	-	-1	32	-	-	550,000
0-150 V AC/DC Inputs	DIO-449	48	1	-	-	-150	150	-	-	400,000
<b>DISCRETE OUTPUTS</b>										
Sourcing Darlington Outputs	DIO-402	24	-	1	80 mA continuous/ 200mA peak	6	36	DNA-PC-912	-	>600,000
Solenoid Drive (Source/Sink), 3.3-36 V DC	DIO-416-32	32	-	0.125	500 mA continuous/ 3.5A peak	3.3	48	-	-	130,000
Sinking Outputs, 3-36VDC	DIO-432	32	-	1	600 mA continuous/ 3.5A peak	3.3	36	-	✓	260,000
Low-leakage, Sinking Outputs, 3-36VDC	DIO-432-800	32	-	1	600 mA continuous/ 3.5A peak	3.3	36	-	✓	260,000
Sourcing Outputs, 3-36VDC	DIO-433	32	-	1	600 mA continuous/ 3.5A peak	3.3	36	-	✓	260,000
Low-leakage, Sourcing Outputs, 3-36VDC	DIO-433-800	32	-	1	600 mA continuous/ 3.5A peak	3.3	36	-	✓	260,000
<b>RELAY OUTPUTS</b>										
Relay Outputs, Form C	DIO-452	12	-	0.125	2 A	0	220VDC- 250VAC	-	-	300,000
Relay Outputs, Form C	DIO-462	12	-	0.125	2 A	0	220VDC- 250VAC	-	-	260,000
Solid State Relay Outputs, Form A (NO)	DIO-463	12	-	0.125	2 A	0	51VDC 35VAC	-	-	260,000
High Current Relay Outputs, Form C	DIO-470	10	-	0.125	5 A	0	220VDC- 250VAC	-	-	300,000

Guardian Series—Includes a variety of powerful diagnostic and BIT functionality.

# I/O Quick Reference Guide

## Serial / CAN Bus (500 Series) • Counter/Timer (600 Series)

Communications Bus Protocol	Part # (DNx-)	Type	# of Chan	Transfer Rate	Notes	Ch-Ch Iso	MBTF
High Speed CAN	CAN-503	CAN	4	1 Mbit	J1939 and CAN .dbc support	✓	350,000
4-port serial	SL-501	RS-232/422/485	4	2 Mbaud	J1587/J1708 support	✓	350,000
4-port high speed serial	SL-501-804	RS-232/422/485	4	4 Mbaud	J1587/J1708 support	✓	350,000
HDLC/SDLC Synchronous	SL-504	RS-232/422/423/485	4	4 Mbaud	Async, bisync, HDLC, SDLC support	✓	290,000
8-port serial	SL-508	RS-232/422/485	8	1 Mbaud	Built-in Interrogation Scheduler	✓	290,000
GP Synchronous Serial Interface	CT-602-804	General Purpose	4	16Mbaud	RS-422/485 logic levels, Tx, Rx,	✓	350,000
Counter/timer function	Part # (DNx-)	Type	# of chan	Clock Rate	Notes	Ch-Ch Iso	MBTF
High Speed Counter / Timer	CT-601	32 Bits	8	66 MHz	Debouncing on ext clock & gate	-	350,000
Differential Counter / Timer	CT-602	32 Bits	4	66 MHz	RS-422/485 logic levels	✓	350,000
Quadrature Encoder Input	QUAD-604	A,B, & Z inputs	4	16.5 MHz	Buffered or Single point readings	-	350,000
IRIG Timing Gen & Synch	IRIG-650	A/B/E/G type	4	1, 5, 10 MHz	On-board GPS receiver	✓	240,000
Variable Reluctance RPM/RPS	VR-608	50 mV - 250 V p-p	8	50 kHz	Adaptive threshold w/index tooth	✓	180,000

Remote Serial Server available for all RS232/422/485 boards on Linux and Windows.

## Avionics I/O

Protocol	Part #(DNx-)	Type	# of Chan	Transfer Rate	Notes	Ch-Ch Iso	MBTF
ARINC-429	429-566	6TX / 6RX	12	12.5/100 kHz	Williamsburg V1 Support	-	470,000
ARINC-429	429-512	12RX	12	12.5/100 kHz	Williamsburg V1 Support	-	470,000
ARINC-708/453	708-453	2TX / 2RX	2	1 Mbaud	Weather or Ground Prox Radar	✓	275,000
ARINC-825	CAN-503	4 Ports	4	83.3-1000 kb	Sensors, Actuators	✓	350,000
AFDX & ARINC-664	AFDX-664	2 ports	2	100,000 kb	Dual Redundant or Independent	-	130,000
1553 (Dual Redundant)	1553-553	2 ports	2	1 Mbaud	Bus Cont, Remote Term, or BM	✓	275,000
M272/PRF/PIM	CT-602-808	M272 and PRF/PIM	1	1 Mbaud	Hellfire Missile Interface	n/a	350,000

## Wireless Communications

Wireless Protocol	Part # (DNx-)	Type	# of Chan	Transfer Rate	Notes	Ch-Ch Iso	MBTF
Wireless (GSM, CDMA, WIFI)	CAR-550	PCIe Mini Compatible	1	-	For GigE UEIPAC chassis	-	300,000
GPS receiver and IRIG I/O	IRIG-650	Passive or active ant.	1	-	Time derived from GPS/IRIG string	-	275,000
GPS Receiver module	DNA-GPS	Garmin 16 series	1	1 PPS	Weather or Ground Prox Radar	-	200,000

## Power Supplies

Output Voltage	Part # (DNx-)	# of Chan	Output V	Current (max)	Notes	Ch-Ch Iso	MBTF
15 V	PC-911	1	+/- 15V	1.2 A	Current/Voltage Feedback	-	150,000
24 V	PC-912	1	+24V	1.6 A	Current/Voltage Feedback	-	150,000
45 V	PC-913	1	+/- 45V	0.4 A	Current/Voltage Feedback	-	150,000



# Cube and RACKtangle Chassis Accessories

## RACKtangle Mounting Options:



### DNR-EXT-BRACKET-4

Optional four inch extended mounting brackets for the DNR-series chassis



### DNR-BRACKET

Standard brackets (included with each chassis)

## DNR-RACK Fillers:

### DNR-IO-FILLER (Filler for Unused RACK slots)

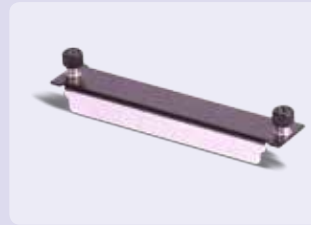

- Single slot filler for unused RACKtangle slots.
- Highly recommended to maintain proper forced air cooling
- Not required for "Cube" systems

## Cube Mounting Options:



### DNA-DR5/8

DIN Rail mounting option



### DNA-FLANGE

Flange mount allows the Cube to be mounted to any flat surface

## Cables:



### DNA-CBL-37S

37-conductor male to female shielded cable available in 1, 3, 10 and 20 foot lengths



### DNA-CBL-62

62-conductor male to male shielded cable available in 3, 10 and 20 foot lengths

## Screw Terminal Panels:



### DNA-STP-37

37-conductor screw terminal panel



### DNA-STP-3762

Universal 37 and 62-conductor screw terminal panel

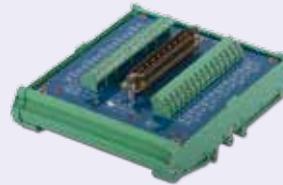

### DNA-STP-37HC

37-conductor STP with 5 Amp ratings for use with DNX-DIO-470.



### DNA-STP-62

62-conductor screw terminal panel



### DNA-STP-AI-U

Universal Terminal Panel for DNA/DNR-AI-207/225 analog input layers



### DNA-STP-AI-207TC

Thermocouple input terminal panel for the DNA/DNR-AI-207 analog input layer



### DNA-STP-AI-208

8-channel direct-connect strain gauge terminal panel for hte DNX-AI-208



### DNA-TADP-37/62

Test adaptor placed in-line with cables brings all pins out to convenient test pins

## Screw Terminal Panels: (continued)



### DNA-STP-SYNC-1G

Sync connector interface simplifies synchronizing Cubes and RACKtangles.

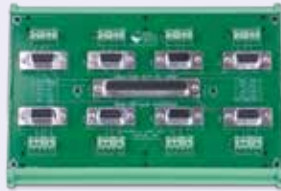

### DNA-STP-508

DNx-SL-508 breakout board brings the 8 serial ports out to DB9 connectors

## Other Options:



Standard

Conformal coated

### Conformal Coating

Optional conformal coating (please call or email us for details on coatings).



### Optional 5-Year Warranty

DNA/DNR-series products include a 2-year warranty. A 3-year extension is available.

## System Burn-In

All DNA- and DNR-series are fully burned-in for a minimum of 12 hours prior to shipment. Our burn-in is much more than simply applying power and looking for smoke. We test all input and outputs constantly during the burn-in process. We also cycle power on and off every 2-3 minutes during the burn-in process.



## Introducing UEI's Video Library

Check out our rapidly growing collection of concise, informative videos – sure to inspire you and help you get the most from your UEI solution. [www.ueidaq.com/videos](http://www.ueidaq.com/videos)

### A FEW OF OUR MOST POPULAR VIDEOS:



**How to control an aircraft throttle** using UEI RVDT synchro board and display results in real-time via onboard webserver

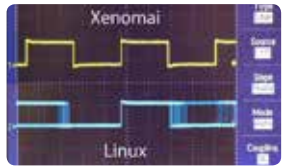

**Jitter: Linux v. Xenomai**– See how deterministic and reliable you can make your system using Xenomai Real-time extensions



**How to Build a LabVIEW Application for UEI Data Acquisition** from scratch and interface with UEI hardware



**A Complete 1553 Solution from UEI (BC, RT and BM)** works for a Bus Controller, Remote Terminal and Bus Monitor systems

[SEE THEM ALL](#)

# PCI/PDXI Data Acquisition Boards

Part Number	Bus	Analog Input				Analog Output		Digital I/O		CTR	
		Res. (bits)	Speed	S.E.	Differential	Res. (bits)	Channels	Inputs	Outputs	Counters	Depth (bits)
<b>PCI Multifunction Boards</b>											
PD2-MF-16-2M/14H	PCI	14	2.2 MS/s	16	8	12	2	16	16	3	16
PD2-MF-64-2M/14H	PCI	14	2.2 MS/s	64	32	12	2	16	16	3	16
PD2-MF-16-3M/12H	PCI	12	3 MS/s	16	8	12	2	16	16	3	16
PD2-MF-16-3M/12L	PCI	12	3 MS/s	16	8	12	2	16	16	3	16
PD2-MF-64-3M/12H	PCI	12	3 MS/s	64	32	12	2	16	16	3	16
PD2-MF-16-500/16L or H	PCI	16	500 kS/s	16	8	12	2	16	16	3	16
PD2-MF-64-500/16L or H	PCI	16	500 kS/s	64	32	12	2	16	16	3	16
PD2-MF-16-400/14L or H	PCI	14	400 kS/s	16	8	12	2	16	16	3	16
PD2-MF-64-400/14L or H	PCI	14	400 kS/s	64	32	12	2	16	16	3	16
PD2-MF-16-333/16L or H	PCI	16	333 kS/s	16	8	12	2	16	16	3	16
PD2-MF-64-333/16L or H	PCI	16	333 kS/s	64	32	12	2	16	16	3	16
PD2-MF-16-150/16L	PCI	16	150 kS/s	16	8	12	2	16	16	3	16
PDL-MF-16-150/16H	PCI	16	150 kS/s	16	8	12	2	16	16	3	16
PDL-MF	PCI	16	50 kS/s	16	8	12	2	24	24	3	24
PDL-MF-333	PCI	16	333 kS/s	16	8	12	2	24	24	3	24

<b>PCI Multifunction Simultaneous Sampling Boards</b>											
Part Number	Bus	Res. (bits)	Speed	S.E.	Differential	Res. (bits)	Channels	Inputs	Outputs	Counters	Depth (bits)
PD2-MFS-4-2M/14	PCI	14	1.6 MS/s	4	4*	12	2	16	16	3	16
PD2-MFS-8-2M/14	PCI	14	1.6 MS/s	8	8*	12	2	16	16	3	16
PD2-MFS-4-1M/12	PCI	12	1 MS/s	4	4*	12	2	16	16	3	16
PD2-MFS-8-1M/12	PCI	12	1 MS/s	8	8*	12	2	16	16	3	16
PD2-MFS-4-800/14	PCI	14	800 kS/s	4	4*	12	2	16	16	3	16
PD2-MFS-8-800/14	PCI	14	800 kS/s	8	8*	12	2	16	16	3	16
PD2-MFS-4-500/16	PCI	16	500 kS/s	4	4*	12	2	16	16	3	16
PD2-MFS-8-500/16	PCI	16	500 kS/s	8	8*	12	2	16	16	3	16
PD2-MFS-4-500/14	PCI	14	500 kS/s	4	4*	12	2	16	16	3	16
PD2-MFS-8-500/14	PCI	14	500 kS/s	8	8*	12	2	16	16	3	16
PD2-MFS-4-300/16	PCI	16	300 kS/s	4	4*	12	2	16	16	3	16
PD2-MFS-8-300/16	PCI	16	300 kS/s	8	8*	12	2	16	16	3	16

Part Number	Bus	Analog Output		Digital I/O		CTR	
		Res. (bits)	Channels	Inputs	Outputs	Counters	Depth (bits)
<b>PCI Analog Output Boards</b>							
PD2-AO-8/16	PCI	16	8	8	8	3	24
PD2-AO-16/16	PCI	16	16	8	8	3	24
PD2-AO-32/16	PCI	16	32	8	8	3	24
PD2-AO-32/16HS	PCI	16	32	8	8	3	24
PD2-AO-32/16HC	PCI	16	32	8	8	3	24
PD2-AO-96/16	PCI	16	96	8	8	3	24
PD2-AO-96/16HS	PCI	16	96	8	8	3	24
PDXI-AO-8/16	cPCI/PDXI	16	8	8	8	3	24
PDXI-AO-16/16	cPCI/PDXI	16	16	8	8	3	24
PDXI-AO-32/16	cPCI/PDXI	16	32	8	8	3	24

Part Number	Bus	Special Functions			Digital I/O			CTR	
		HS Counter	HS Streaming	Sequencer	DIO	DIn	DOut	Counters	Depth (bits)
<b>PCI Digital I/O Boards</b>									
PD2-DIO-64	PCI				64			3	24
PD2-DIO-128	PCI				128			3	24
PD2-DIO-128i	PCI					64	64		
PDL-DIO-64	PCI				64			3	24
PDL-DIO-64CT	PCI	.	.		64			3	24
PDL-DIO-64ST	PCI		.		64			3	24
PDL-DIO-64TS	PCI	.	.	.	64			3	24
PDXI-DIO-64	cPCI/PDXI				64			3	24
PDXI-DIO-64CT	cPCI/PDXI				64			3	24
PDXI-DIO-64ST	cPCI/PDXI				64			3	24
PDXI-DIO-64TS	cPCI/PDXI				64			3	24

# FAQs

## When would you recommend a UEIPAC versus a UEILogger?

The UEILogger allows you to completely set up and run an application without programming in any language. The complete application is set up in a small number of simple dialogue boxes. This makes the UEILogger an ideal solution for those who do not wish to program. The limitation of this configuration is the only functions you may implement are those built into the UEILogger application itself.

The UEIPAC requires the user to program in C, in Linux (or Cygwin for Windows) operating system. This allows the UEIPAC to offer application flexibility well beyond the functions of the UEILogger. The UEIPAC also allows the chassis to provide control functions not implemented on the UEILogger.

## I've read about real time operating systems that run in windows. In particular, do you support the INtime and/or RTX real-time operating systems? Also, isn't "real-time" under Windows an Oxymoron.

The INtime and RTX applications are both supported by UEI and both do support hard real-time functionality under Windows. These applications actually run on the core of the PC, underneath Windows and with higher priority. RTX and INtime perform the real-time function implemented and then, and only then, allow Windows to use the PC resources remaining.

## Will the UEIPAC also function as a PDNA series Cube/RACKtangle slaved to a host PC over the Ethernet?

The UEIPAC will function as a PDNA type slave, but only in programmed I/O mode. Our DMAP real-time protocol or ACB high speed circular buffer mode are not supported by the UEIPAC in this mode.

## Can I connect to a PowerDNA Cube/RACKtangle via wireless interface?

As the PowerDNA cubes and RACKTangles use a standard Ethernet interface, they can be connected wirelessly with commonly available wireless interfaces. The one thing to check before selecting your wireless interface is that it can be set to connect to a device with a static IP address. Some of the less expensive wireless points have no method to set the static IP. Also, the UEIPAC may take advantage of the DNA-CAR-550 board which allows either 802.11 series WIFI interfaces or GSM/CDMA phone connections.

## Does UEI offer any type of FPGA based I/O board that I can customize with my own FPGA code for special functions?

Absolutely. Many of our I/O boards are two board base/daughter board configurations. The base board provides the interface to the PowerDNA backplane as well as a large Altera Cyclone series FPGA. We are happy to share the details of the FPGA interface with our customers wishing to design their own I/O functionality.

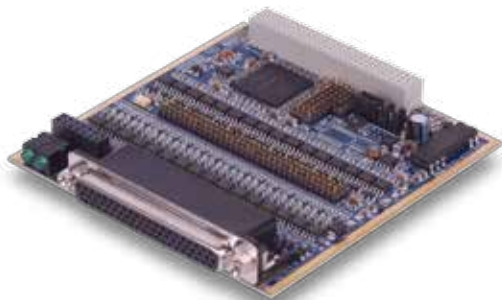

Customers wishing to develop their own, custom I/O boards may build a special purpose daughter card for use with our standard FPGA base board.

## How does the UEI RACKtangle I/O system compare with competitive VME based systems?

The UEI RACKtangle compares very favorably with competitive VME systems. First and foremost, our customers are appreciative of our 10-Year availability guarantee as many people we speak to are concerned their VME solutions may be discontinued at any time. The UEI system will typically provide equivalent or superior performance in a smaller package and at a lower cost.

## Does the UEIPAC support any operating systems other than Linux?

Yes. The UEIPAC can be based on VxWorks. We do not have the license to install VxWorks on your PAC, but we are happy to show you how you may. Our PowerDNA Cubes and RACKs run a very compact operating system called  $\mu$ COS. We are happy to work with our customers on a special project basis if they are interested in programming an application in  $\mu$ C. Though not open source,  $\mu$ C is very compact and fast, and has been certified as DO-178 compliant.

## Can you mix Cubes and RACKtangles in the same system.

Absolutely. In fact, the electronics in both the Cubes and RACKs are identical. The only difference is the mechanical form factor. This not only means you can mix Cubes and RACKtangles in an application, it means you can switch from one form factor to the other without rewriting your code or changing any field wiring.

## How large can a PowerDNA system be?

Almost arbitrarily large. We have been used on military aircraft flight simulators requiring greater than 7,000 I/O points. We've also done temperature systems with over 1,700 thermocouples and structural analysis applications with over 1,500 strain gages.

## I noticed you had a 100Base-FX version of the cube. Why would I want a fiber interface?

There are really three reasons. The first is distance from the host. A single-mode fiber can communicate reliably at up to 20 km from the host. The second is isolation. The fiber interface provides almost infinite isolation. If you want to protect your host PC from a lightning strike or the electromagnetic pulse caused by an explosion, you should consider a fiber interface. Finally, noise immunity. The fiber interface is virtually immune to EMF interference. Need to run your cable by the arc welder? You want fiber.

## Can I arrange a demo system?

Of course. All UEI hardware orders with a total price of \$10,000 or less are covered by our 30-day money back guarantee. Place your order and try the system before you need to make a final decision. (BTW, our software is available on our web site as a free download. If you want to "play" with the software prior to purchase, download it and fire it up.)

## Where are UEI products manufactured?

All UEI products are manufactured in the USA.

## Will UEI consider a "special" product for us?

Absolutely. Many of our new products are based on "specials" for a customer. However, rather than building a special, we typically like to release the product as a standard item we can offer to other customers. As a standard product it's easier for us to make sure we keep the product up to date with the latest software and testing. As an FYI, we like to treat NRE as a break-even proposition and not a profit center. People are often surprised at how inexpensive it may be to get a "special" product (either HW or SW) produced.

### Does the UEIPAC offer “hard” real-time capability?

Yes. The UEIPAC supports Linux’s Xenomai real-time functionality. Also, should you want to use VxWorks, we can show you how to load and run it on your UEIPAC.

### What options are available for mounting the Cube?

Though some customers simply count on gravity to keep the cube on their table-top, most customers take advantage of either the DNA-FLANGE flange mount or DNA-DR series DIN rail mounts. Please see page 35 or visit our web site for details.

### Do you offer the option to run your Cubes and RACKtangles from DC Power?

Yes. All Cubes/RACKs are designed to run from any DC power source between 9 and 36 VDC. We also include a universal (120/240 VAC) AC power adaptor with each chassis.

### Do any of your I/O boards offer isolation?

Yes. In fact all of our I/O boards except the DNx-429-5xx series provide 350 Vrms of isolation between the board’s I/O connections and the chassis (as well as all other I/O boards installed).

### Can I add a new board to my Cube in the field or do Cube reconfigurations need to be done by UEI.

You are free to add, change or remove boards from your Cube. It typically takes 15 minutes or so as there are a number of screws to remove and then reinstall. If you anticipate frequently reconfiguring your system we highly recommend you consider the RACKtangle form factor where board replacement takes only a matter of seconds.

## Application Notes and White Papers for Download

### Check out these and more, available online:

#### Case Study: Why FlightSafety International has Standardized on the RACKtangle for Sim/I/O

Discover why FlightSafety International has switched from VME to UEI’s Gigabit Ethernet RACKtangle™ I/O chassis a Modern Alternative — [www.ueidaq.com/simio](http://www.ueidaq.com/simio)

#### White Paper: A Modern Alternative to Reflective Memory and VME

Learn about the use of UEI unique Ethernet I/O chassis as a modern alternative to Reflective VME systems — [www.ueidaq.com/modern-alternative](http://www.ueidaq.com/modern-alternative)

#### White Paper: Introduction to Data Acquisition Parts 1 and 2

This series of white papers, begins in part one by introducing data acquisition technology in general, and then dives into analog inputs specifically, while part two introduces less common forms of I/O — [www.ueidaq.com/daq-intro2](http://www.ueidaq.com/daq-intro2)

#### Application Note: Advanced In-Flight Data Recorder

Taking advantage of the PowerDNA Cube and associated I/O modules, Cessna has designed, built, and tested their new in-flight DAQ in record time — [www.ueidaq.com/ifdr](http://www.ueidaq.com/ifdr)

#### Application Note: Using Accelerometers in a Data Acquisition System

Find out how to use Accelerometers in data acquisition system Using Accelerometers in a Data Acquisition System — [www.ueidaq.com/accelerometers](http://www.ueidaq.com/accelerometers)

#### Application Note: PowerDNA Hardware at Tinker Air Force Base

PowerDNA hardware helps Tinker US Air Force Base achieve design goals for its new engine test cell. — [www.ueidaq.com/tinker](http://www.ueidaq.com/tinker)

#### Application Note: Rocket Test Stand with PowerDNA Cube, and AI-225

Research facility uses PowerDNA cubes, and AI-225 layers with strain-gage sensors to measure high-speed dynamic data from a rocket test stand. — [www.ueidaq.com/rocket-test](http://www.ueidaq.com/rocket-test)

## Typical Applications:



**Flight Simulators:** The RACKtangle I/O chassis has been selected by FlightSafety International as the computer-based I/O hardware for future flight simulators. The UEI system provides the interface between the controlling computers and the simulator's various systems including Avionics Instrument Control (AIC), Control Loading and Motion (CLM) and Flight Deck I/O (FDK). UEI was selected for a variety of reasons. Chief among these were: a) The high channel density allowed the I/O to be installed directly on the simulator, eliminating the need to run literally thousands of wires from the simulator to externally mounted I/O racks. b) The I/O combined with the Gigabit Ethernet interface real-time operating system support allows the simulators to operate at 2000 Hz, providing ultra smooth and realistic flight characteristics, c) The built-in diagnostics of the UEI products, combined with self-test capabilities implemented by FSI reduces installation time, increases MTBF and is expected to increase simulator "in-system availability".

**Data Logger for Trucks:** A major truck manufacturer needed a data logger to monitor a wide variety of systems within vehicles in the field. The application requires a compact, rugged logger that not only monitors the analog and digital inputs, but also logs information from CAN-bus and RS-232 devices, and a GPS. The logger needed to be easily configured with different I/O configurations, as many vehicles have unique I/O requirements. The UEI logger was the perfect solution, providing the environmental (tested: -40 °C to +85 °C), and physical ruggedness (50 g shock, 5 g vibration) required, and the I/O flexibility.

**Landing Gear Test:** A NASA funded research facility needed to test the strength and stability of a landing "gear" designed for a Mars landing vehicle. A landing gear prototype was to be "drop" tested to simulate the stress of an actual landing. The system needed to simultaneously sample 96 strain gages and acquire data from accelerometers, rate gyros and quadrature encoders. It needed to be: 1) light enough not to compromise the prototype's weight or balance, 2) rugged enough to survive 30 g landing forces and 3) wired to a host computer with wires light and flexible enough not to impact the drop dynamics.

**Bridge/Structural Test:** Bridges and tunnels are a key part of our infrastructure. Recent disasters have shown that in some cases this infrastructure has degraded to such a point as to be hazardous. It has become critical to study and determine the health of these structures, both to prevent disaster and to lengthen the service life of these structures. The Fiber-optic-based (100Base-FX) DNA-FPPC5 Cube is an ideal solution, providing the following benefits.

- Real-time measurement spanning over 500 meters
- Reduced wiring costs 90%
- Optical fiber connection offers noise free Ethernet connections
- Optical fiber interface isolates host computer from lightning strikes
- Compact size allows Cube installation close to sensors, thus reducing noise

**Flight Test:** A new entrant in the field of V LJ (Very Light Jets) and a market leader in manufacture of business jets had very similar requirements. Both needed a compact, rugged, 24 VDC powered logger that logs data from analog and digital inputs as well as logging from the ARINC-429 avionics bus, RS-232 devices and a GPS receiver. The logger also needed to be easily configured with different I/O configurations as each different model of aircraft has unique I/O requirements.

The UEI logger is the perfect solution. Not only does it provide the environmental (tested: -40 °C to +85 °C and to 70,000 feet...special versions to 120,000 feet), and physical ruggedness (50 g shock, 5 g vibration) required, but also provides the abil-

ity to select the I/O configuration from an extremely wide variety of analog, digital, counter/timer, Serial, ARINC-429, MIL-STD-1553, CAN and GPS interfaces. This ensures the logger can be configured to exactly match the requirement of a particular jet. The UEI logger's intuitive, easy-to-learn configuration software was critical as each application requires a custom data logging configuration.

Once the data logging application is completed, data may be downloaded in two ways. Data from trucks that return to main garage is obtained by simply removing the SD card from the logger. Trucks that remain in the field were outfitted with CDMA-based high speed Cell Network interfaces. At the end of the session, the data can be downloaded by any host computer with access to the internet.

The DNA-PPC8 PowerDNA cube with its 6 I/O slots fit the bill perfectly. Using the 25-channel DNA-AI-225, all 96 analog input channels could be monitored with four I/O boards, leaving one slot for the DNA-CT-601 counter board for quadrature encoder inputs and one free slot. The entire system fit in a single 4 × 4 × 5.8 cube weighing under four pounds. The PowerDNA Cube's 50 g shock and 5 g vibration specifications also were up to the task. Finally, the Cube's wide 9-36 VDC power requirement meant the system could draw power from batteries already on the simulator, leaving only a simple Ethernet cable required to connect the DAQ system to the host PC.

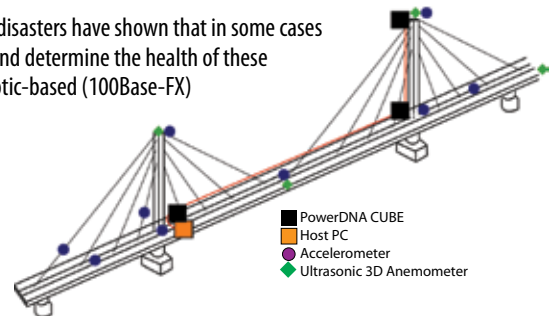

ity to select the I/O configuration from an extremely wide variety of analog, digital, counter/timer, Serial, ARINC-429, MIL-STD-1553, CAN and GPS interfaces. This ensures the logger can be configured to exactly match the requirement of a particular jet. The UEI logger's intuitive, easy-to-learn configuration software was critical as each application requires a custom data logging configuration.

Once the flight test is completed, the logged data may be downloaded in two ways, either by downloading it to a host PC over the Cube's Ethernet port, or by simply removing the SD card and reading it with any standard SD card reader.

**Rocket Launch /Space Vehicle Monitoring and Control:** From ground control to the International Space Station, UEI Cubes are being used to control and monitor a large number of space related applications. Whether the application is military, NASA or with our growing list of commercial space customers the Cube is becoming a staple in the space “industry”.

The distributed nature of the Cubes makes them an ideal solution for ground control as they can be placed in convenient locations, close to the sensors and actuators to be monitored and controlled. The rugged, compact and light form factor, combined with the reliable Linux operating system makes the UEIPAC Cube an ideal local controller for various functions on the rocket itself.

Also, the rugged nature of the Cube, including its ability to function in near vacuum environments (tested to 120,000 feet) make it an ideal solution for space vehicle monitoring as well as hosting high altitude experiments (rocket or balloon-based).

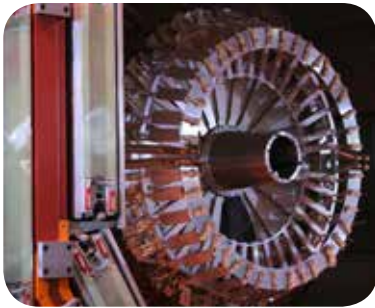

**EPICS-Based Particle Accelerator Instrumentation:** A particle accelerator takes stationary charged particles, such as electrons, and electro-magnetically drives them to velocities near the speed of light. In such applications, timing and synchronization of the system and its various experiments are absolutely critical to achieving trustworthy results. Many of these accelerators use a standardized software environment called EPICS (Experimental Physics and Industrial Control System).

UEI's EPICS software allows you to run your Cube or RACKtangle as a CAS (Channel Access Server), allowing you to configure any I/O input or output as a PV (Process Variable). This support is provided for both PowerDNA and UEIPAC based systems. EPICS support is provided with our standard software distribution and is included in the price of the hardware.

**Storage Tank Monitoring:** The distributed nature of UEI's I/O Cube is particularly well-suited for monitoring temperatures, pressures and thermal expansion in large storage tank facilities. A variety of applications, including spent nuclear fuel rod containment tanks, petroleum/gas refinery tanks, wastewater treatment chambers, and fluid separation basins can require industrial-strength monitoring systems.

The PowerDNA Cube effectively collects measurements taken by thermocouples, pressure transducers and various strain gauges/load cells. Stand-alone Data Recorder/Logger functionality allows data to be stored locally, ensuring no data is lost even if the network goes down temporarily. The new teaming/bonding support on our GigE Cubes even allows simple connections to redundant networks if required. And UEI's 10-Year Availability Guarantee ensures that environmentally sensitive tank monitoring systems are also easy to maintain over many, many years.



**Military Embedded Controller:** Piezoelectric Crystals have two interesting properties that make them unique and PowePC based real-time embedded control in military and defense systems is gaining in popularity, in part because processor cores, microcontrollers and digital signal processors are becoming optimized for reliability, performance and security. Embedded control is used in military applications involving air and ground transportation, fire and weapon safety, command communications, and life-critical systems that require isolation from hacking and signal corruption.

Our new DNA-PPC6-1G-MIL is an ideal solution for a wide array of these applications. As UEI's first product to provide all connections through 38999 connectors, it offers the ruggedness, flexibility and high channel density as our standard Cubes, but with the connectors our military customers expect.

The stand-alone UEIPAC is currently used in a variety of military applications, including remote vehicle control (USV and ULV), shipboard communications, RADAR antenna control, communications translators, engine control and health monitoring.

Our PowerDNA products operating as slave I/O chassis have also been used in a wide assortment of military applications. Our factory written support for VxWorks, QNX and Linux ensure we have the ability to run in the high reliability operating system many of our military customers require.

## Typical Applications:



**Space Station Astronaut Treadmill:** NASA selected a UEIPAC Cube for controlling the COLBERT treadmill in the new space station exercise facility. The astronauts need the treadmill both for exercise and for maintaining bone density in a gravity-free environment. Some of the functions monitored by the UEIPAC are characteristics of the astronaut's gait and foot impact forces while using the treadmill. This is determined by sensing data from accelerometers and load cells in the treadmill and associated restraining equipment. The fact that the UEIPAC hardware is a very compact, rugged, radiation-resistant design that makes efficient use of conductive cooling makes the unit ideally suited for space applications.

**Underwater Vehicle Controller:** A major university marine research center has successfully completed sea trials of a new deep water ROV that uses on-board UEI PowerDNA Cube and I/O hardware/software to provide dynamic control of 5 forward/reverse thrusters (2 horizontal,

2 vertical, and 1 lateral), auxiliary system control, temperature/electrical system supervision, and an interface to the data telemetry equipment. The ROV and associated surface vessels are capable of operating the ROV depths up to 1000 meters.

**Air Force Jet Engine Test Cell:** The Air Force has produced a "next generation" standard design of a test cell for high performance testing of a wide range of gas turbine engines. The new system is designed to enable development of independent, standardized tests for specific engine types. Since each thrust frame is separable from the cell, it can be configured and calibrated as an off-line task, independent of the cell in which it will be installed. It is ready for quick setup whenever a test is scheduled — without modifying the test cell itself.

The UEI DAQ equipment moves with the thrust frame so it can be configured, tested, and calibrated with the engine either in or out of the test cell. It can be disconnected from the cell by simply removing the single Ethernet cable and power connection.

The quick setup design is a significant aid in achieving rapid and efficient test turnaround.



**Land and Sea Vehicle / Power Plant Simulators :** When someone says "Simulator", most people immediately think about flight simulators. However, in an effort to save money, as well as to provide better, quicker and safer training, many organizations such as military, emergency service, and even bus companies are moving to simulator-based training for their drivers. Military trainers in particular are basing much of their driver training on very complex and realistic simulators. The simulator can provide a realistic experience of driving a tank, personnel carrier, or MRAP in a convoy at night while under attack. These are very real conditions that are very difficult to train for in actual vehicles.

For the same reasons as in the flight simulator industry, UEI's RACKtangle has become the standard for a wide variety of companies building ground vehicle simulators. The combination of small footprint and real-time update speed make UEI's RACKtangle an ideal ground vehicle simulator solution. Interestingly, UEI's wide selection of I/O capabilities is often more critical in ground simulators than flight. In addition to the standard analog and digital I/O, most military ground simulators also require a combination of serial, CAN, ARINC-429 and/or MIL-1553. UEI's support for all of these functions have helped make it a leader in this market.



**Simulator Rehosting:** UEI has become a market leader providing I/O for use in new simulators. The same reasons so many simulator manufacturers use UEI for their new Sims also make our I/O linkage an ideal solution for rehosting that older simulator that is still viable, but needs new computers and I/O systems. These reasons include:

- a. 10 year guaranteed product availability (many existing sims can't be maintained as critical I/O boards are no longer available).
- b. The availability of all the I/O (including avionics) you will need from one company under one API.
- c. Outstanding diagnostics and self-test to help debug and maintain the simulator.
- d. Ethernet connectivity provides easy distribution around the Sim.
- e. Compact size allows the I/O to be easily installed in existing locations
- f. High speed (up to 4000 Hz) allows a smooth professional "feel" even when controlling CLM
- g. Attractive pricing



**High Channel Structural/Stress Testing:** Whether you're testing the safety of an existing bridge, confirming that a new airframe conforms to the stress/strain model it was designed to, or testing an aging air frame to ensure it's still up to the job, the distributed Ethernet based configuration of the UEI system is ideal. The small size of the Cube allows it to be "buried"

almost anywhere and can be placed in close proximity to the sensor. Standard, copper Ethernet allows the I/O chassis to be up to 100 meters from the host PC. In bridge, or other large scale civil engineering testing, the 100Base-FX fiber interface allows the chassis to be up to 20 km from the host. If local (in chassis) storage is desired, the UEIPAC or UEILogger are perfect solutions.



**Wind Power Generator Monitor and Control:** UEI Cubes, and in particular, the UEIPAC, are ideal solutions for monitoring and controlling wind power generators. Powerful enough to provide control for everything from blade angle to output voltage and log everything from wind speed to power output. Also, the UEIPAC's easy access to Ethernet means it can easily run as a slave to a primary host PC when desired, but can take over and run stand-alone if anything happens to the primary communications link. The Cube's rugged environmental specifications eliminates the need for any heating or cooling in the control rack.

**Piezoelectric Sensor AND Actuator Interface:** Piezoelectric Crystals have two interesting properties that makes them unique and powerful both as a sensor, and as a controller/actuator. On the sensor side, when a piezoelectric crystal is deformed, it generates an output EMF. This characteristic is the basis for the vast majority of vibration sensors as well as many popular audio input sensors. The industry standard for this type of sensor is actually a two-wire interface that, depending on the manufacturer may be called ICP, IEPE or a variety of other names. The common thread is that the two-wire interface provides power via a constant current source (typically 1-4 mA) and then returns the output voltage "on top" of the current source. UEI's popular DNx-AI-211 is an ideal ICP/IEPE interface.

The second key property of piezoelectric crystals is they deform (slightly) when a voltage is placed across them. This makes them an ideal means to

make VERY small movements, and in particular, the piezoelectric crystal is commonly used as a way to modulate and/or control mirrors in optical applications. One disadvantage of using piezo crystals to control mirrors is that the displacement per volt is very small and large analog output voltages are required. UEI's PD-AO-AMP-115 buffer is designed to drive up to  $\pm 115$  VDC.

In perhaps the most interesting piezoelectric applications we've seen, we have customers developing very sensitive optical systems that use ICP/IEPE sensors to measure localized vibration errors (from something like a truck driving by), and then using piezoelectric crystals on a number of mirrors to "cancel" out these vibrations (similar to the active noise canceling in your headphones).

## Typical Applications:

**Replacing Obsolete VME Racks:** People have been predicting the demise of the VME bus ever since the PC was released. Well, it's still not dead, but many customers are beginning to look for alternatives. Though most VME vendors are still happy to sell and update their expensive processor products, many are walking away from their less profitable I/O products. OEMs in particular are switching to new technology in order to ensure a continued source of the "parts" used in their systems. If you're an OEM and you're concerned your VME supplier is about to start talking about end-of-lives and last-time-buys, you need to look at the RACKtangle. The RACKtangle (and Cube!) platforms are a perfect alternative to aging VME technology. All DNR and DNA series products are covered by UEI's 10-Year Availability Guarantee!



*The 3U RACKtangle Ethernet I/O chassis is the perfect replacement for an aging VME-based I/O system*

**Dynamometer Control:** A major manufacturer of dynamometers has standardized on the PowerDNA cube as the I/O system used to monitor and control their large dynos. The dynamometers are sold to customers worldwide and used in a wide variety of automotive, aircraft and railroad applications, testing both engine and brake performance. Previous systems had been based on shipping a dynamometer to the customer site in two pieces, the mechanical "machine" and the control racks. Company installation technicians then placed the dyno and the control racks in place and went through the tedious and time consuming task of

connecting the hundreds of control and monitoring wires between the control rack and the dynamometer.

The PowerDNA's high density I/O, combined with its environmental ruggedness, allows the entire I/O system to be mounted directly on the dynamometer. In the new configuration, when the units are installed at a customer facility, the dyno is installed and the host computer is placed in the control room. The field technicians then need only connect power and Ethernet to the dynamometer. The application was developed in C, and runs on standard Windows operating systems.

**High Channel Count Temperature Monitor:** A major appliance manufacturer automated temperature measurement in a CSA oven test stand. Though conceptually a simple application, the system requires monitoring over 1700 thermocouples. The previous solution involved four technicians monitoring a bank of digital panel meters and making manual entries into a test log. This inefficient, error-prone method was replaced by 18 PowerDNA DNA-PPC8 Cubes "filled with" DNA-AI-207 analog input boards. The Cubes are distributed around the test chamber, minimizing the length of thermocouple wire required. The built-in sin-

gle port Ethernet switch provided in the PowerDNA Cube allows the Ethernet to be daisy chained from one cube to the next. The entire system is implemented using a single Ethernet port on the host computer.

Software for this system was written in C++ using the UEIDAQ Framework. The Framework provides a powerful, yet simple set of drivers that may be called from all popular programming languages and application packages (e.g., LabVIEW, MATLAB) and supports Windows/Vista. UEI also provides a high level API to support Linux and most popular Real-Time operating systems including QNX, RTX, and VxWorks.

**Automotive NVH:** UEI's popular UEILogger Cube in conjunction with our DNA-AI-211 ICP/IEPE interface and our DNA-AI-208 or AI-224 strain gage interfaces have been used by a wide variety of customers in the study of vehicle NVH (Noise, Vibration and Harshness) characteristics. The Cube is an ideal measurement platform for in-vehicle automobile NVH testing. The Cube is small, rugged and runs off any power supply between 9 and 36 VDC. This combination makes it easy to "bury" the cube in the car's trunk, engine compartment or under a seat. In addition to logging the NVH data, the UEILogger can also acquire CAN data, allowing simply correlation between the vehicle dynamics (e.g., speed, RPM) and NVH. All this is possible without writing any code as the UEILogger is programmed by a simple, intuitive Windows GUI.



**In-Vehicle Health Monitoring:** Whether your supporting or designing a military or commercial aircraft, a truck, bus, tractor, train, ship or submarine, it's always better to identify a pending system failure before it fails. It's safer, simpler and less expensive to correct a problem on the ground, at the maintenance barn, or in port, than it is to deal with a failure while the vehicle is "out". We have a variety of customers using our UEILogger or UEIPAC Cubes to monitor the health of various aircraft, ground vehicles, ships or boats.

Applications range from very simple, obvious measurements to those based upon complex highly proprietary analysis. On the simple end of the spectrum, we have customers with systems that simply monitoring a truck or bus CAN network, or aircraft ARINC-429 or MIL-STD-1553 and look for trends in operating temperature, pressure or fuel flow.

In more complex applications, we have customers running very complex vibration

analysis to identify degradation in bearings, transmissions and/or turbines. This data can then be correlated with other information acquired allowing the implementation of a very powerful predictive maintenance program.

In simpler applications, the health monitor simply logs data to a local SD card which is then downloaded periodically and analyzed as a post-acquisition process. In more complex or critical applications the UEIPAC is configured to provide real-time analysis of the various data inputs and identify problems or possible pending failures while the vehicle is in the field. This data can then be displayed locally, to inform the pilot/driver/captain of the issue allowing him/her to plan accordingly. Finally, we have customers using our UEIPAC with the CAR-550 communications interface to provide WIFI or Cell Phone interfaces that send real-time data, and warnings of problems to a central maintenance facility so the support team is prepared for any required maintenance or repairs.

**Remote Serial Communications:** We have a number of customers who use UEI's Cubes and RACKtangles as remote communications links. Applications for remote serial communications include:

- Power plants where the host needs to communicate with devices on the other side of the plant.
- Shipboard where a host PC needs to communicate with a series of devices in other cabins and even other decks within the ship.
- Simulators where the host PC needs to control a variety of serial devices in the cockpit.
- Wind farms where the system needs to consolidate RS-485 data from a series of turbines and send the data to the supervisory computer.

The UEI systems are an ideal solution for wide variety of reasons.

1. They're rugged and can be installed where most commercially available serial solutions will not survive.
2. We can provide up to 96 serial ports in a single chassis and locate it up to 100 meters from the host.
3. Using our DNA-FPPC8 series fiber optic cubes, you can locate your remote serial ports up to 20 km from the host.
4. Our powerful UEI-RSS allows you to program each com port like any standard COM port in your Windows or Linux PC. There is NO PROGRAMMING required to connect to a remote serial port!

**Unmanned Land Vehicle (ULV) Control:** A large military operation in the development of an Unmanned Land Vehicle needed a rugged, low power, high density controller for the vehicle, as well as a comprehensive and flexible system to handle all of the unit's I/O. The unit also needed to be very flexible, as depending on the end application of the ULV, many different types of sensors and controls would be installed. Finally, in order to preserve experience with other vehicles and to ensure fast and robust system operation, the unit was required to be Linux-based.

The UEIPAC Programmable Automation Controller was the perfect solution. It provides the environmental (tested: -40 °C to +85 °C), and physical ruggedness (50 g shock, 5 g vibration) required and allows the installation of up to 6 I/O boards in a single 4" × 4" × 5.8" Cube. It runs a standard Linux operating system and has the ability to be easily configured with a wide variety of analog, digital, counter/timer, quadrature encoder, Serial and GPS interfaces. The software is written on a standard Linux PC (or may be written in a Windows environment under Cygwin) using UEI's powerful and yet simple API.

**Portable and Field Test Units:** UEI's Cube and RACKtangle chassis has been the basis for a variety of compact, powerful field test units. The combination of small size, high shock and vibrate immunity, wide temperature ranges and low power make them ideal sub-systems in larger, turn-key test systems. Of course that we now have over 60 different I/O boards is also critical as we know that you can't test only 98% of the system. With our huge variety of I/O, we're sure to have everything your system requires, not only to measure your inputs, but to provide all of your required excitation signals.

The UEIPAC is the perfect platform for a fully stand-alone test system. All the software runs locally on the Cube or RACKtangle so there is not host PC required. This makes the system more efficient, more reliable and eliminates the need for an expensive ruggedized laptop host. In some systems, it's important to keep the host PC as the controller and using our PowerDNA/DNR chassis allows tight, real-time control of the test system even from a remote host. Finally, some customers use the UEIPAC as a local controller that runs under the guidance of a local host. The actual test is run on the UEIPAC, but the host PC selects which test is to be run. The UEIPAC's web interface provides an interface where the supervisory computer need only provide a web browser in order to control the tests.

### Other applications include:

- Power plant efficiency testing
- High channel count medical instrumentation
- Modernization of Modbus-based I/O systems
- Machine health monitoring
- Wind turbine automation
- Jet engine test
- Metal rolling and forming monitoring and control
- Building security monitoring and access control
- HVAC control
- Environmental chamber monitoring and control
- Hardware in-the-loop testing
- Embedded machine control
- Semiconductor manufacturing

## Six DAQ/Control Functions:

### Ethernet I/O: Data Logger: PAC:

PowerDNx Ethernet-based I/O systems for data acquisition and real-time control.

The UEILogger is an easy-to-use data logger ideal for a wide variety of applications.

The UEIPAC (Programmable Automation Controller) is an ideal embedded control solution.

### Simulink I/O: Modbus TCP: OPC-UA:

The UEISIM lets you deploy and test Simulink models on real hardware.

The UEIModbus allows your Modbus applications to run with a modern I/O solution.

The UEIOPC-UA offers a solution for any OPC-UA based host PC.

## Versatile Form Factors:

### 100Base-T/100Base-FX Cubes



### Gigabit Ethernet-based Cubes



### UEINet



### PowerDNR FLATRACK™



### DNA-MIL Cube



### DNR-MIL RACKtangle™



### PowerDNR RACKtangle™



### PowerDNR HalfRACK™



## Extensive I/O:

DNA series for Cubes | DNR series for RACKtangles  
DNF series for FLATRACK

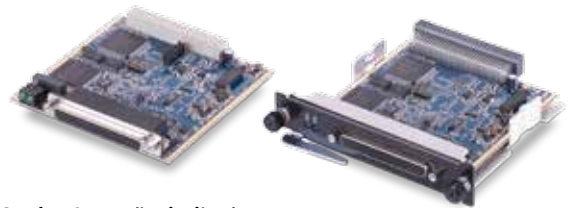

- Analog Input (including)
  - Thermocouple
  - Strain Gage
  - Voltage/Current
  - ICP/IEPE
- Analog Output
  - Standard  $\pm 10$  VDC
  - High Voltage (to  $\pm 115$  VDC)
  - High Drive (to 250 mA)
- Digital I/O
- ARINC 429
- ARINC 453/708
- MIL-STD-1553
- AFDX®
- Counter/Timers
- IRIG B sources/slaves
- LVDT/RVDT Input
- Simulated RVDT/LVDT outputs
- RS-232/422/485 Communication
- SDLC/HDLC Communications
- CAN Bus
- PWM input and output
- Quadrature Encoder inputs

- Synchro/Resolver
- Simulated Synchro/Resolver output
- Relay output
- WIFI/GSM interfaces
- Plus much more...

### Great Software too!

Complete factory written support for Windows/Vista/7/8, Linux and all popular RTOS's including QNX, VxWorks, RTX, INtime and more plus high level support for popular languages and application packages including LabVIEW, MATLAB, Simulink and DASyLab.

Your Local Sales Representative or Distributor: