

Service Manual

SPD3303C Programmable DC Power Supply

SM0503C-E01A

2017 SIGLENT TECHNOLOGIES CO., LTD

Guaranty and Declaration

Copyright

SIGLENT TECHNOLOGIES CO., LTD All Rights Reserved.

Trademark Information

SIGLENT is the registered trademark of **SIGLENT TECHNOLOGIES CO., LTD**

Declaration

- **SIGLENT** products are protected by patent law in and outside of P.R.C.
- **SIGLENT** reserves the right to modify or change parts of or all the specifications or pricing policies at company's sole decision.
- Information in this publication replaces all previously corresponding material.
- Any way of copying, extracting or translating the contents of this manual is not allowed without the permission of **SIGLENT**.
- **SIGLENT** will not be responsible for losses caused by either incidental or consequential in connection with the furnishing, use or performance of this manual as well as any information contained.

Product Certification

SIGLENT guarantees this product conforms to the national and industrial standards in china as well as the ISO9001: 2008 standard and the ISO14001: 2004 standard. Other international standard conformance certification is in progress.

General Safety Summary

Review the following safety precautions to avoid personal injuries and prevent damages to this product or any products connected to it. To avoid potential hazards, use this product only as specified.

Only qualified personnel should perform service procedures.

To Avoid Fire or Personal Injuries

Use Proper Power Cord. Use only the power cord specified for this product and approved by local state.

Avoid Electric Shock. To avoid injuries or losses of life, do not connect or disconnect probes or test leads while they are connected to a voltage source.

Ground the Product. This product is grounded through the protective terra conductor of the power line. To avoid electric shock, the grounding conductor must be connected to the earth. Make sure the instrument is grounded correctly before connecting its input or output terminals.

Connect the Probe Properly. Do not connect the probe ground lead to a high voltage since it has the isobaric electric potential as ground.

Observe All Terminal Ratings. To avoid fire or shock hazard, observe all ratings and markers on the instrument and check your manual for more information about ratings before connecting.

Use Proper Fuse. Use only the specified fuse.

Do Not Operate Without Covers. Do not operate this instrument with covers or panels removed.

Avoid Circuit or Wire Exposed. Do not touch exposed junctions and components when the unit is powered.

Do Not Operate With Suspected Failures. If you suspect damage occurs to this instrument, have it inspected by qualified service personnel before further operation. Any maintenance, adjustment or replacement especially to the circuits or accessories should be performed by SIGLENT authorized personnel.

Keep Product Surfaces Clean and Dry.

Do Not Operate in Wet/Damp Conditions. To avoid electric shock, do not operate the instrument in wet or damp condition.

Do Not Operate in an Explosive Atmosphere. To avoid injuries or fire hazards, do not operate in an explosive atmosphere.

Safety Terms and Symbols

Terms on the Product. These terms may appear on the product:

DANGER: Indicates an injury or hazard that may immediately happen.

WARNING: Indicates an injury or hazard may be accessible potentially.

CAUTION: Indicates damage to the instrument or other property may occur.

Symbols on the Product. These symbols may appear on the product:



**Hazardous
Voltage**



**Refer to
Instructions**



**Protective
Earth
Terminal**

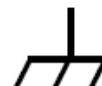

**Chassis
Ground**



**Test
Ground**

Content

Guaranty and Declaration	1
General Safety Summary	2
Specification	5
Calibration	7
Calibration Interval	7
Adjustment is Recommended.....	7
Automating Calibration Procedures	7
Recommended Test Equipment	7
Test Considerations.....	8
Performance Verification Test.....	8
Constant Voltage (CV) Test.....	9
Constant Current (CC) Test.....	10
General Adjustment Procedure	11
Software Environment	11
Warming up.....	11
Output Current Calibration.....	12
Output Voltage Calibration.....	13
Assembly Procedures.....	14
Security Consideration.....	14
Required Tools	14
Disassembly Procedures.....	15
Troubleshooting	24
ESD Precautions	24
Required Equipments	24
Power Board Drawing.....	25
Main Board Drawing.....	26
Check the Power Board.....	27
Voltage Checking	27
Check the Main Board	29
Voltage Checking	29
Quick Guide for General Failures	30
Maintenance.....	31
Maintain Summary	31
Repackaging for Shipment.....	31
Contact SIGLENT	32

Specification

Test conditions: warm-up for at least 30 minutes, with temperature between +18°C ~ +28°C and .

Output Ratings	CH1/CH2 independent	0~32V , 0~3.2A
	CH1/CH2 series	0~64V , 0~3.2A
	CH1/CH2 parallel	0~32V , 0~6.4A
	CH3	2.5V/3.3V/5.0V , 3.2A
Constant Voltage Mode	Line regulation	≤0.01%+3mV
	Load regulation	≤0.01%+3mV
	Ripple and noise	≤1mVrms (5Hz ~ 1MHz)
	Recover time	≤50μs(50% load change ,minimum load 0.5A)
	Temperature coefficient	≤300ppm/°C
Constant Current Mode	Line regulation	≤0.2%+3mA
	Load regulation	≤0.2%+3mA
	Ripple and noise	≤3mA _{rms}
CH3	Line Regulation	≤0.01%+3mV
	Load Regulation	≤0.01%+3mV
	Ripple and noise	≤1mVrms (5Hz ~ 1MHz)
Tracking Operation	Track error	≤0.5%+10mV of Master(No Load)
Parallel Mode	Line Regulation	≤0.01%+3mV
	Load Regulation	≤0.01%+3mV
Series Mode	Line Regulation	≤ 0.01%+5mV
	Load Regulation	≤ 300mV
Resolution	Voltage	10mV
	Current	10mA
Display	Ammeter	3.2A full scale, 3 digits LED display
	Voltmeter	32V full scale, 4 digits LED display
Accuracy	Program accuracy	Voltage: ± (0.5% of reading + 2digits) Current: ± (0.5% of reading + 2digits)
	Readback accuracy	Voltage: ± (0.5% of reading + 2digits) Current: ± (0.5% of reading + 2digits)
Insulation	Case to terminal	20MΩor above (DC 500V)
	Case to AC line	30MΩor above (DC 500V)
Operating environment	Indoor	
	Elevation	≤2000 m
	Environment temperature	0 ~ 40°C
	Relative humidity	≤80%
	Installation level	II

	Pollution level	2
Storage environment	Environment temperature	-10 ~ 70°C
	Relative humidity	≤ 70%
Power supply	AC 100V/120V/220V/230V±10%, 50/60HZ	
Size	275mm x 225mm x 136mm	
Weight	7.5kg	

Calibration

This calibration procedure contains performance verification procedures and adjustment procedures. After receiving a generator, it is recommended to first confirm that the performance is related to the specifications. If so, then perform the appropriate adjustments.

Calibration Interval

The instrument should be calibrated on a regular interval determined by the measurement accuracy requirements of your application. A 1-year interval is adequate for most applications. Accuracy specifications will remain valid only if adjustment is made at regular calibration intervals. Accuracy specifications are not valid beyond the 1-year calibration interval. **SIGLENT** does not recommend extending calibration intervals beyond 2 years for any application.

Adjustment is Recommended

Specifications are valid only within the period from the last adjustment. Whatever calibration interval you select, **SIGLENT** recommends that re-adjustment should always be performed within the calibration interval. This is necessary to ensure the accuracy of the performance data measured during the calibration interval.

Automating Calibration Procedures

The complete verification and adjust procedures can be automated with the use of appropriate automated test instrumentation. The complete instrument configurations specified for each test may be programmed via the remote interface. Verification data can then be read-back from the instrument into a test program and compared to the appropriate test limit values.

The instrument can also be adjusted from the remote interface. Remote adjustment is similar to the local front-panel procedure. A PC can be used to perform the adjustment by first selecting the required function and range. The adjustment command is sent to the instrument and then the adjustment is initiated over the remote interface.

Recommended Test Equipment

The test equipment instrumentation recommended for the performance verification and adjustment procedures is listed below. If the exact instrument is not available, substitute with the instrument of equivalent accuracy.

Instrument	Requirements	Recommended Model
Digital Multimeter (DMM)	DC voltage/current: accuracy: 100 ppm resolution: 100 $\mu\text{V}/\mu\text{A}$	Siglent SDM3055
DC Electronic Load	specification: 80V/20A/200W	ITECH IT8702

Test Considerations

For optimum performance, all procedures should comply with the following recommendations:

- Assure that the calibration ambient temperature is stable and between 18°C and 28°C. Ideally, the calibration should be performed at 23°C \pm 1°C.
- Assure ambient relative humidity is less than 70%.
- Allow a 30 minute warm-up period before verification or adjustment.
- Keep the measurement cables as short as possible, consistent with the impedance requirements.

Performance Verification Test

The performance verification tests are recommended as acceptance tests upon receipt of the instrument. The acceptance test results should be compared against the specifications given in chapter “**Specification**”. After acceptance, repeat the performance verification tests at every calibration interval.

If the instrument fails performance verification, adjustment or repair is required.

Constant Voltage (CV) Test

1. Set the DMM to measure DC voltage. Connect the DMM to the CH1(CH2) output of the SPD3303C as shown below.



2. Turn on CH1(CH2) and change the current setting value to 0.1A.
3. Set the instrument to each output value described in the table below, then verify the voltage readback value and measure the output voltage with the DMM..

Output voltage setting	Output/Readback voltage limits
0 mV	-20 mV ~ 20 mV
100 mV	79.5 mV ~ 120.5 mV
1 V	0.975 V ~ 1.025 V
10 V	9.93 V ~ 10.07 V
25 V	24.855 V ~ 25.145 V
30V	29.83 V ~ 30.17V

4. Compare the measured voltage to the spec range shown in the table above.

Constant Current (CC) Test

1. Set the DMM to measure DC current. Set the DC Electronic Load to constant current mode and set the current value to 3.2A. Connect the DMM to the CH1(CH2) output of the SPD3303C as shown below.

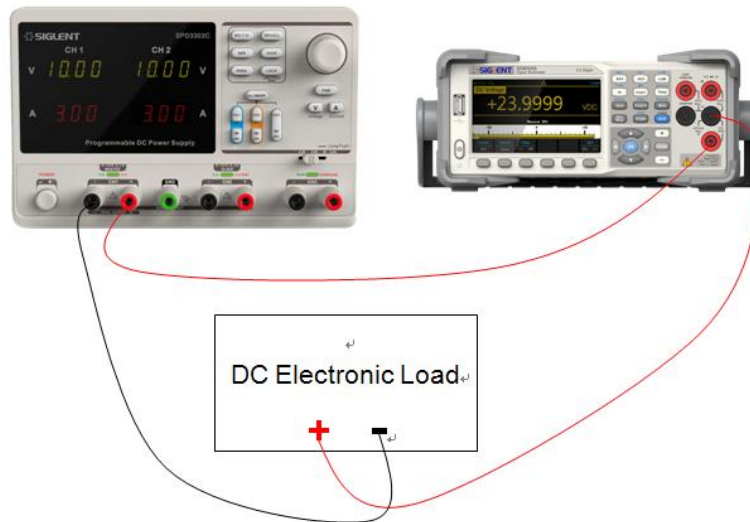

2. Turn on CH1(CH2) and change the voltage setting value to 30V.
3. Set the instrument to each output value described in the table below, then verify the current readback value and measure the output current with the DMM..

Output current setting	Output/Readback current limits
0 mA	-20 mA ~ 20 mA
100 mA	79.5 mA ~ 120.5 mA
1 A	0.975 A ~ 1.025 A
2.5A	2.4675 A ~ 2.5325 A
3 A	2.965A ~ 3.035 A

4. Compare the measured current to the spec range shown in the table above.

General Adjustment Procedure

The following explains how to adjust the SPD3303C power supply for optimum operating performance.

- **Output Voltage Calibration** which calibrates the output voltage accuracy.
- **Output Current Calibration** which calibrates the output current accuracy.

Software Environment

1. Python

Make sure you have installed Python 2.7 in your computer. The following modules of Python are required as well: PyVisa, PyQt4 and PyWin32.

2. Microsoft Office

As test reports are saved as '.xls', it is necessary that you are working with MS Office 2003 or higher version.

3. NI VISA

The Python module, PyVisa, is based on VISA I/O library which can be derived from NI VISA.

Warming up

Before performing the adjustment procedures, let the generator and other test equipment warm up for at least 30 minutes in an ambient temperature between 18 °C and 28 °C. Adjustments performed prior to warm-up or outside this temperature range may result in poor performance.

Output Voltage Calibration

1. Connect the DMM, PC and SPD3303C generator as shown below:

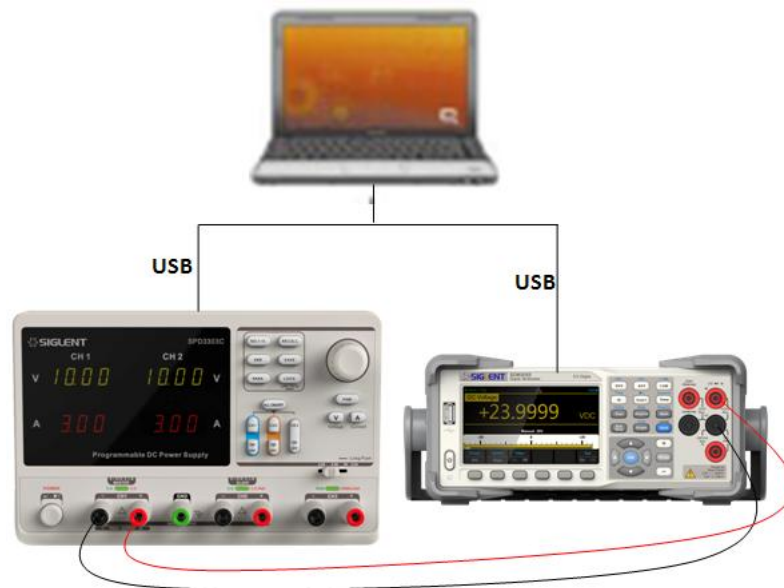

2. Double click and run the script **VoltageCalib.py** prepared previously. Then Change the channel connection according to the prompt message.

Output Current Calibration

1. Connect the DMM, PC and SPD3303C generator as shown below:

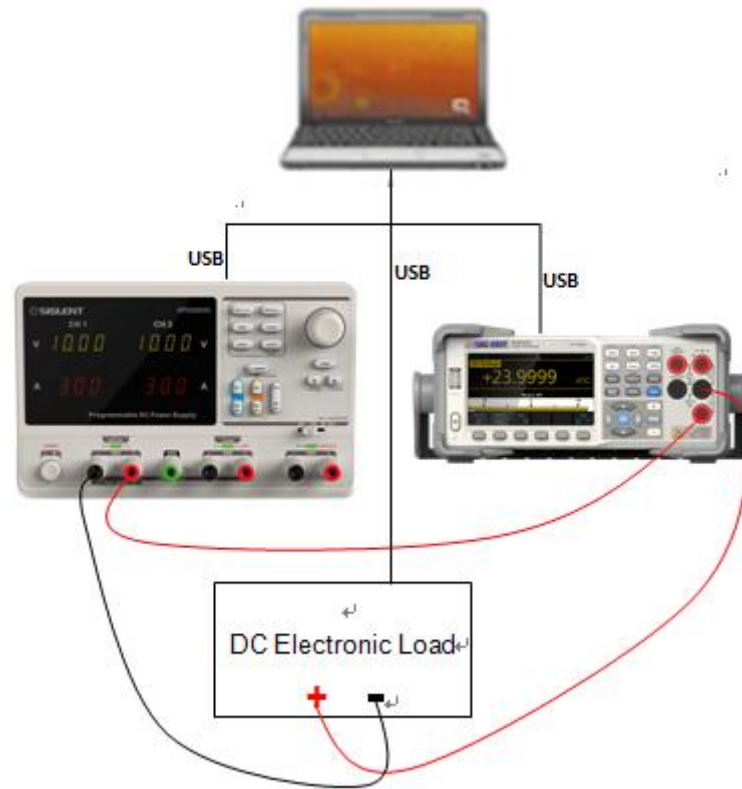

2. Double click and run the script **CurrentCalib.py** prepared previously. Then Change the channel connection according to the prompt message.

Assembly Procedures

This chapter describes how to remove the major modules from the SPD3303C series generator. To install the removed modules or replace new modules, please follow corresponding operating steps in reverse order.

Security Consideration

Only qualified personnel should perform the disassembly procedures. Whenever possible, disconnect the power before removing or replacing. Otherwise, personal injuries or damages to the components may occur.

Avoid Electric Shock Hazardous voltages exist on the power supply module. To avoid electrical shock, disconnect the power cord from the generator, and then wait at least three minutes for the capacitors in the generator to discharge before beginning the disassembly.

Preventing ESD Almost all electrical components can be damaged by electrostatic discharge (ESD) during handling. Component damages can occur at electrostatic discharge voltages as low as 50 volts. The following guidelines will help preventing ESD damage when servicing the instrument or any electronic device.

- ◆ Disassemble instruments only in a static-free work area.
- ◆ Use a conductive work area to reduce static charges.
- ◆ Use a conductive wrist strap to reduce static charge accumulation.
- ◆ Minimize handling.
- ◆ Keep replacement parts in original static-free packaging.
- ◆ Remove all plastic, foam, vinyl, paper and other static-generating materials from the immediate work area.
- ◆ Use only anti-static solder suckers.

Required Tools

Use these tools to remove or replace the modules in the generator:

- Anti-static gloves
- The multifunctional screwdriver or electric screwdriver
- Needle-nose pliers

Disassembly Procedures

Step 1: Remove handle components

Remove the 2 PCS KM4 * 16 screw, handle fixed tablet (2 PCS) and handle.

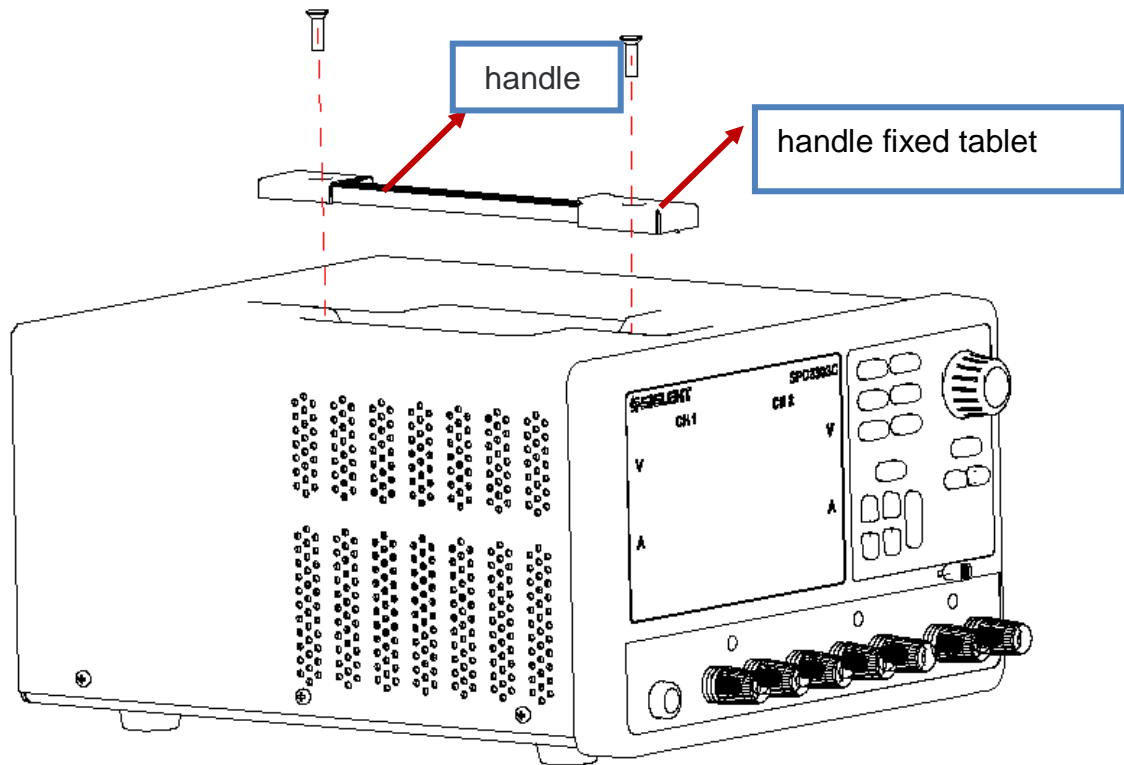

Step 2: Remove the metal plate

Remove 6 PCS screw on two sides, then remove the metal cover plate.

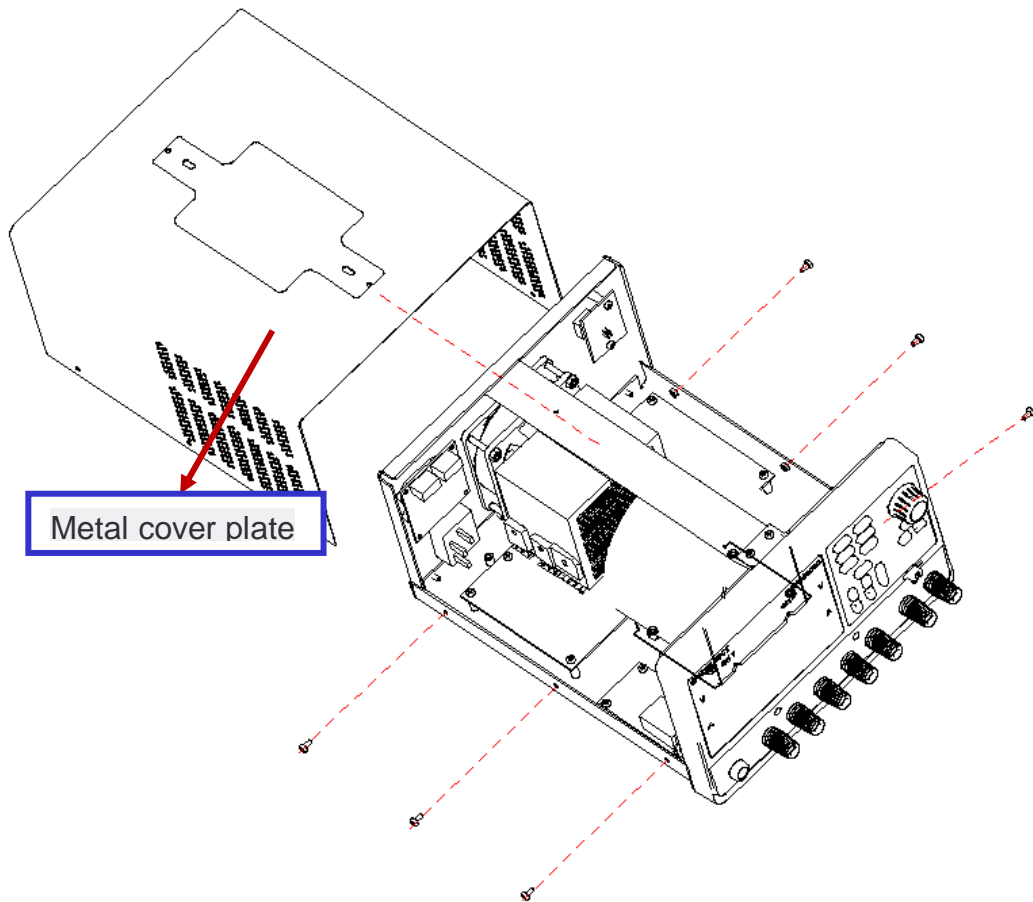

Step 3: Remove the handle strut bone

Removed 4 PCS screws as shown in the figure below, and remove the strut bone according to the direction indicated by the arrow.

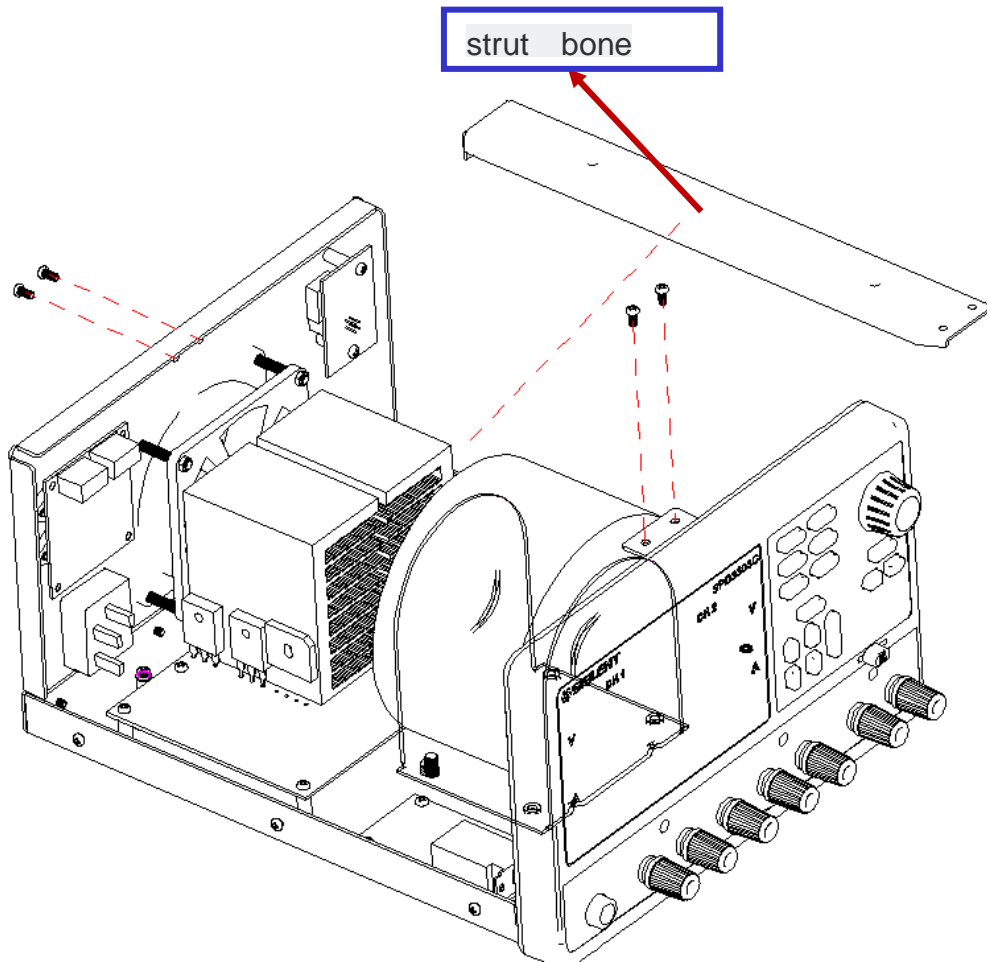

Step 4: Separate the front panel and the hardware components

Remove 4 PCS screws and the cables between the front panel and hardware baseboard, remove the front panel and the power button.

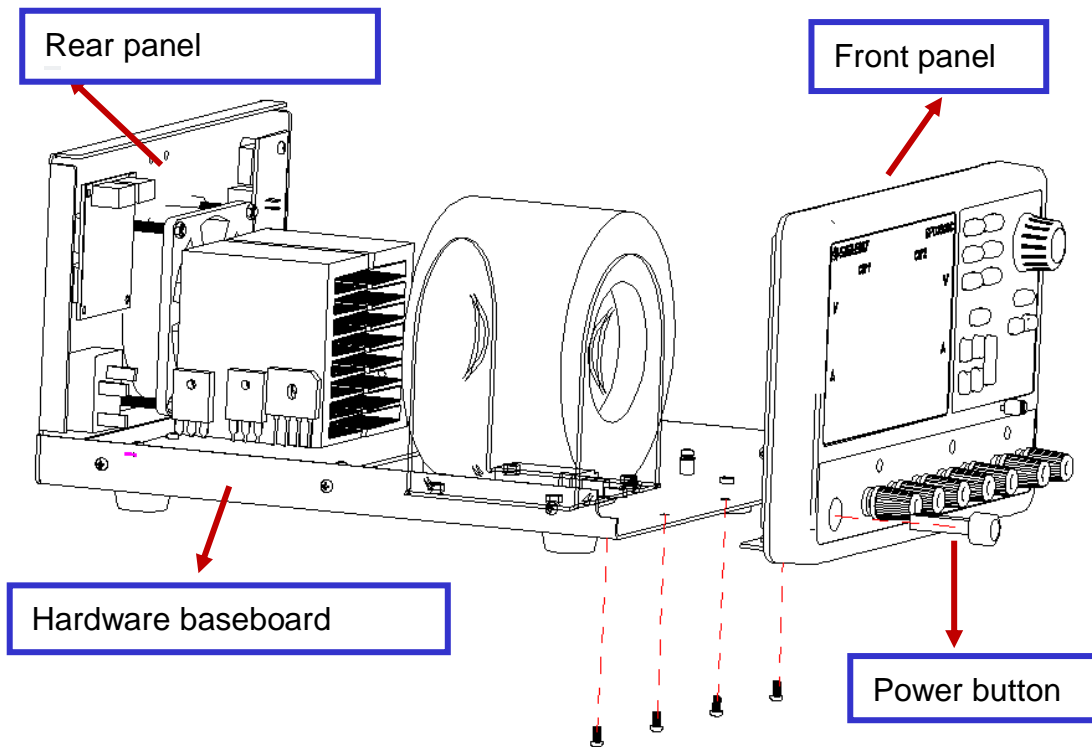

Step 5: Remove the front panel components

Remove the 4 PCS screws, 7 PCS combination screw, screen ribbon cable on the main control board, then the main control board, wave button cap and 7 PCS terminal can be removed; Remove 4 PCS screw between the metal front panel and plastic shell, then the metal front panel can be removed; Remove 6 PCS screw on key board, then the key board can be removed

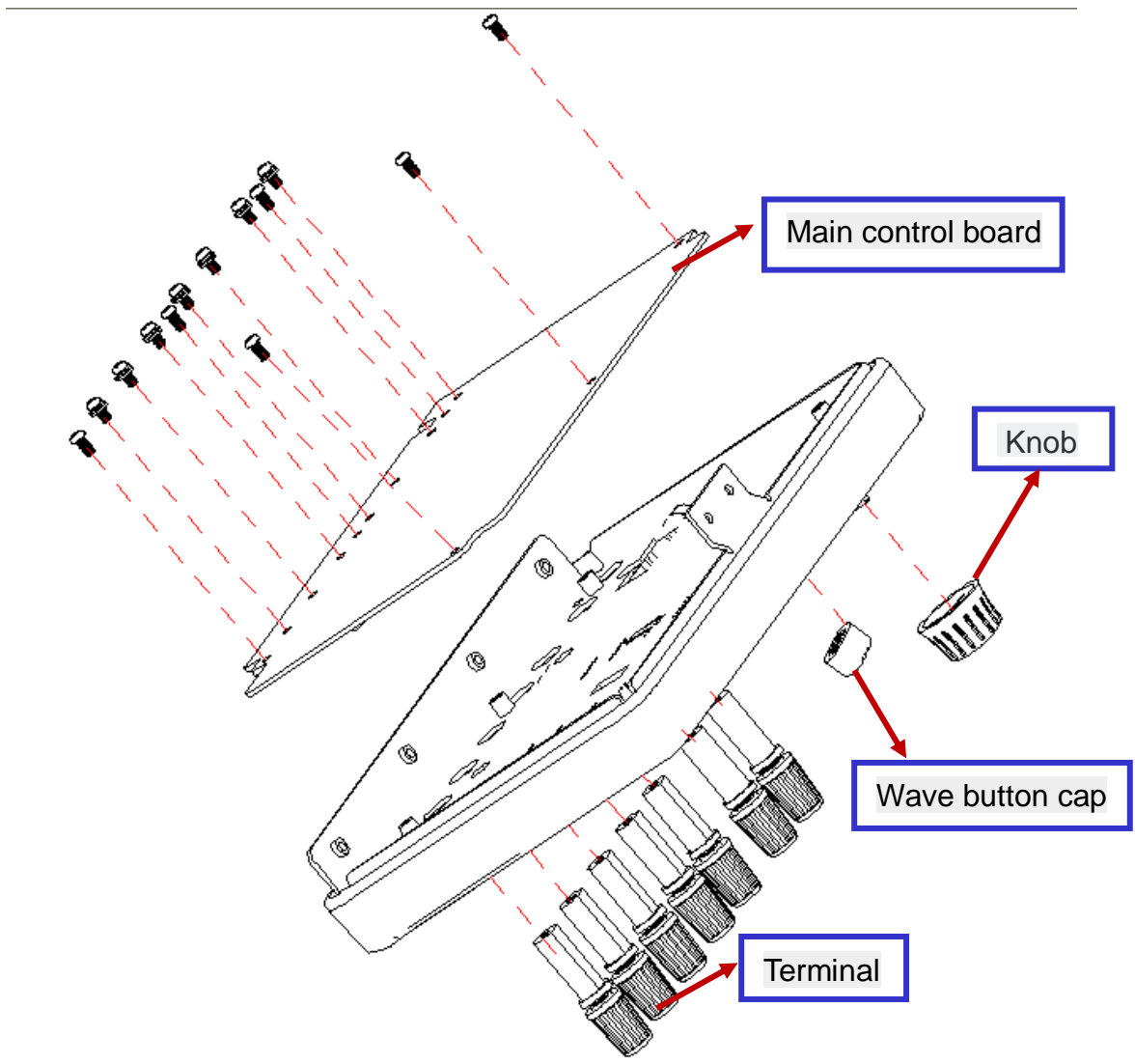

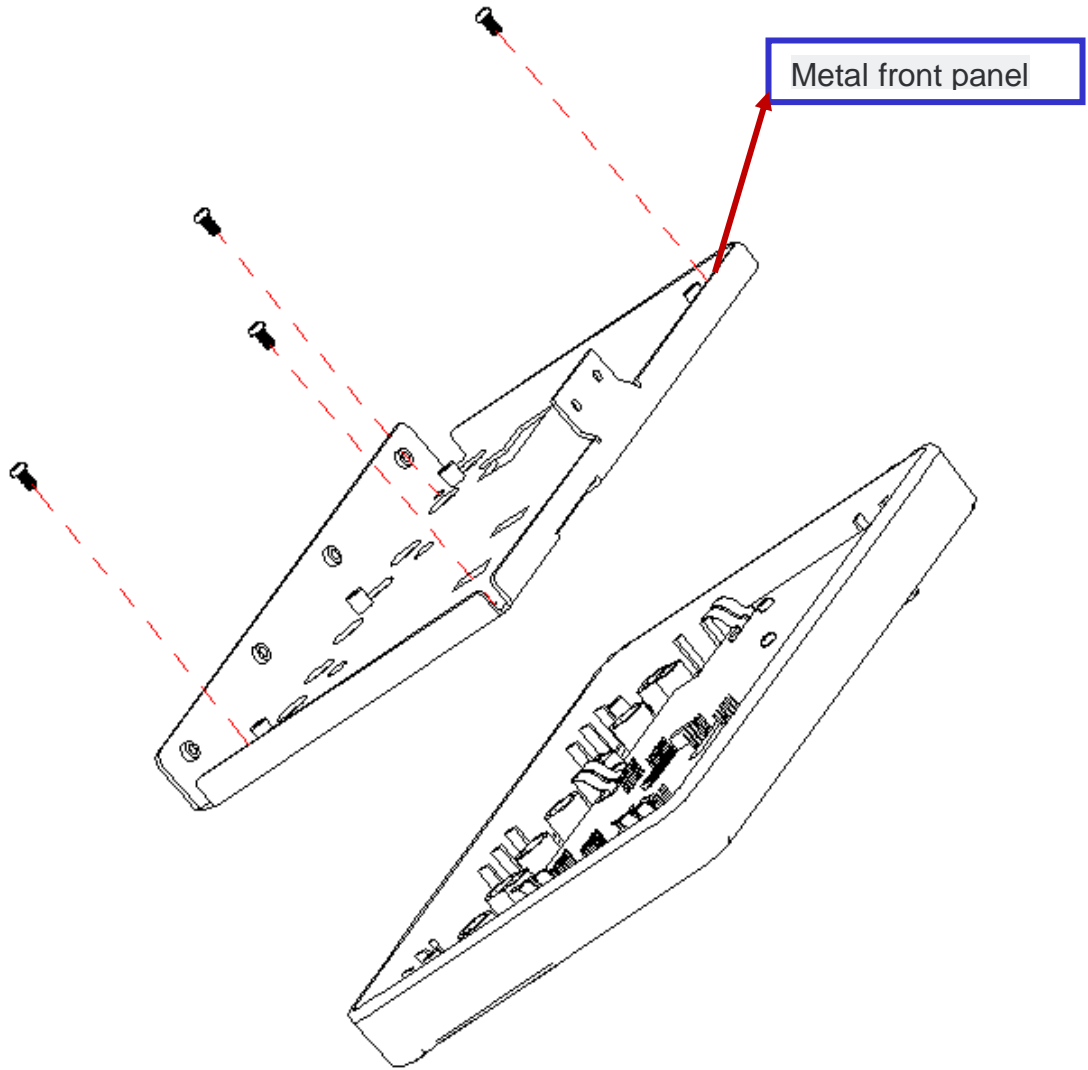

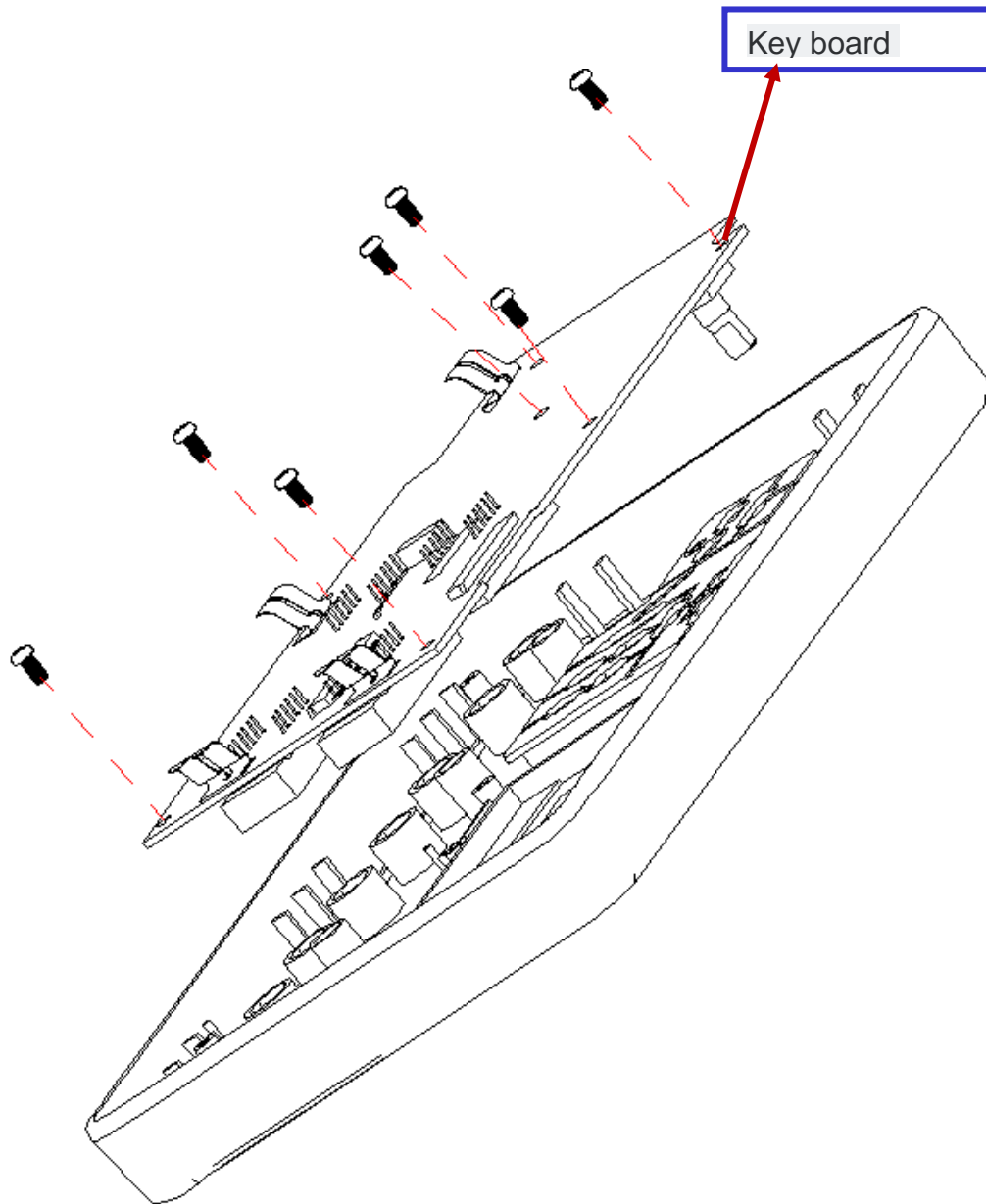

Step 6: Remove hardware components

Remove 4 PCS screws and the cable between hardware rear pannel and hardware baseboard, then the hardware components can be removed

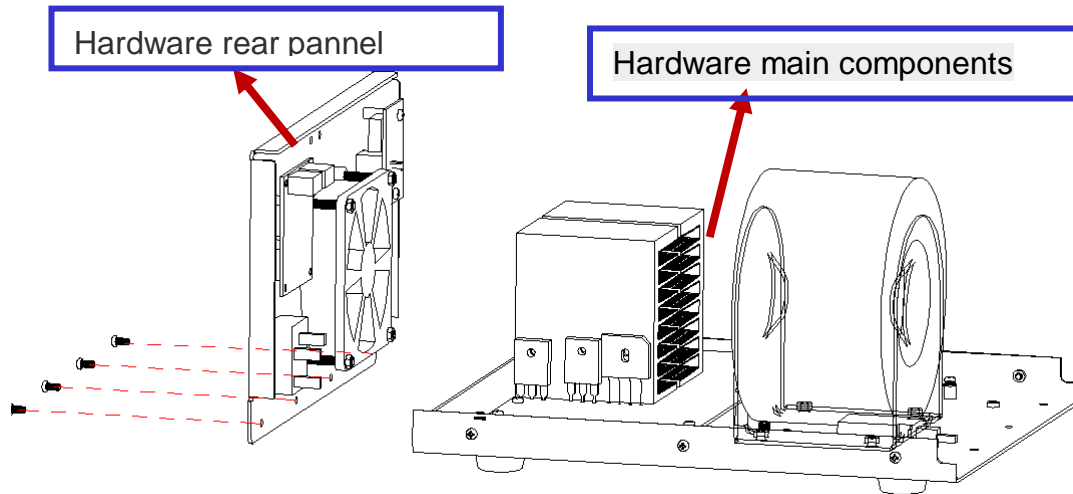

Step 7: Remove hardware rear panel components

Remove 6 PCS screws, then the power AC switch board and USB board can be removed; Remove the 4 PCS screws, then the fan can be removed.

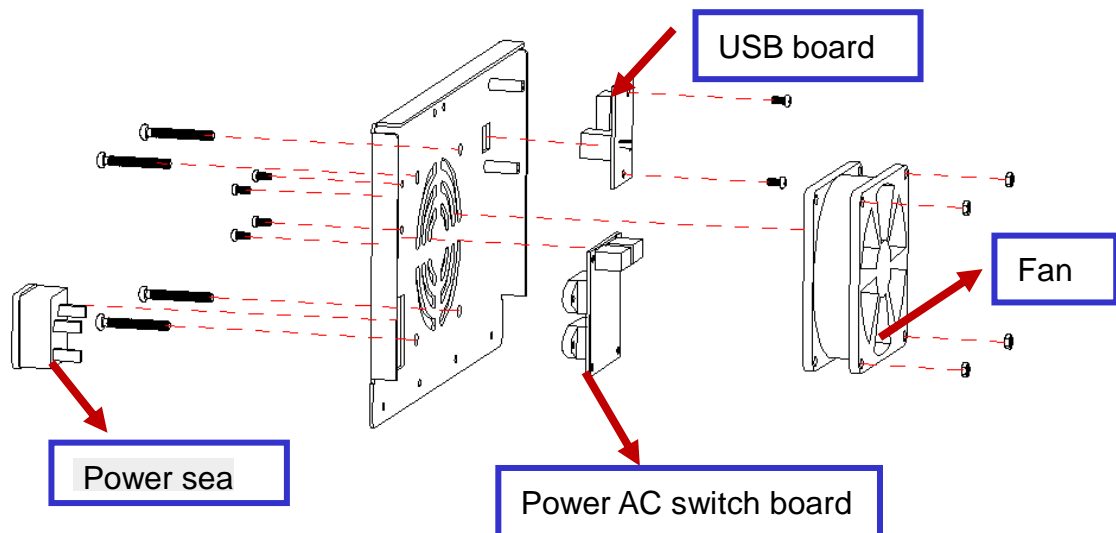

Step 8: Remove hardware main component

Remove 10 PCS screws and the cables, then the small power board and power switch board can be removed; Remove the 8 PCS screws, then the transformer and floor mats can be removed.

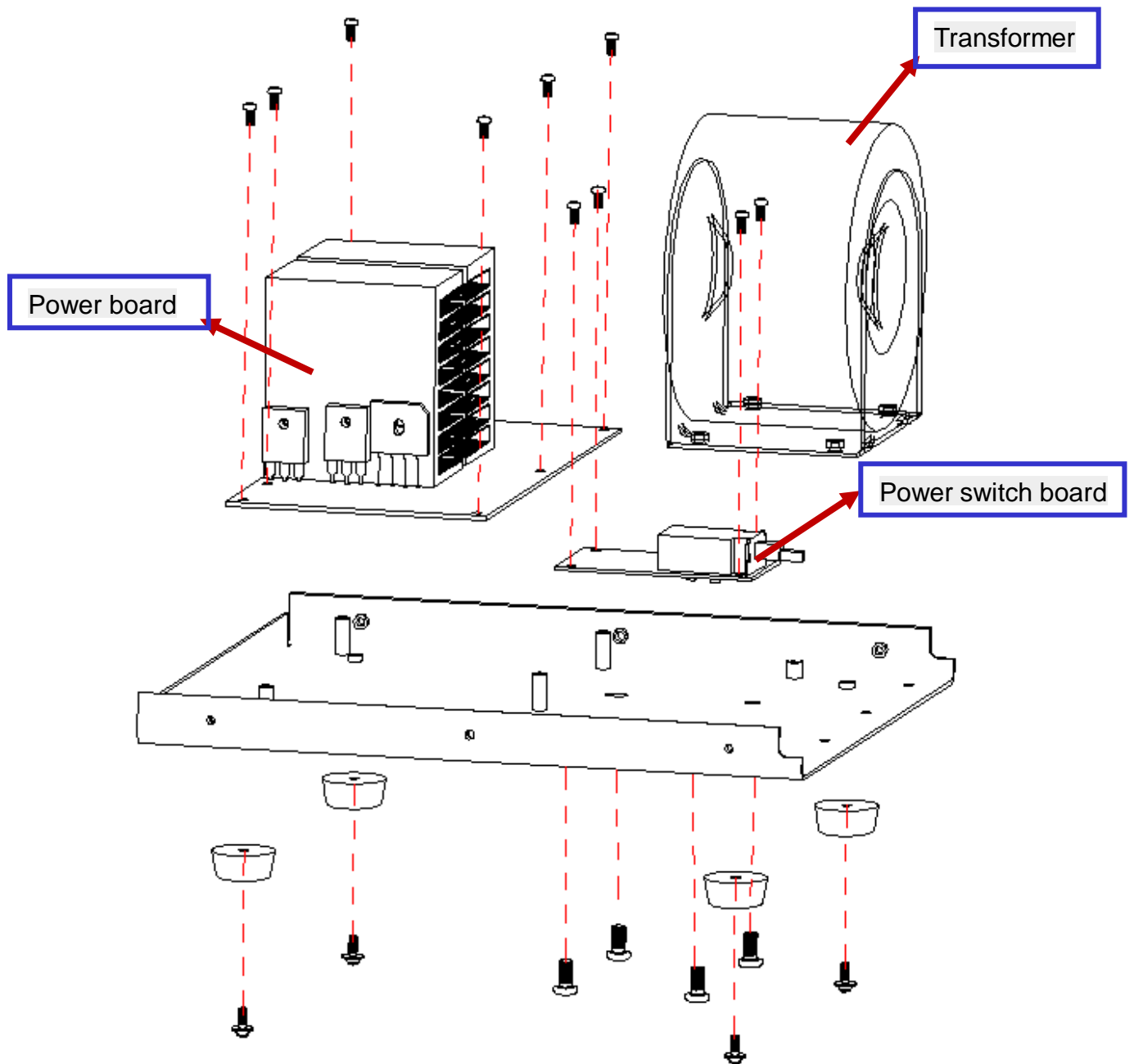

Note:

To assemble the generator, please follow these same steps in reverse order.

Troubleshooting

The internal structure of the SPD3303C Power Supply consists of power board, main board and switching board, and they are linked through cables or connectors. This chapter explains the main checking procedures for these three boards by measuring the rated test points on them, thus to help you decide the reason for the failure you encounter while operating SPD3303C.

ESD Precautions

While performing any internal test of the SPD3303C, please refer to the following precautions to avoid damages to its internal modules or components result from ESD.

- Touch circuit boards by the edges as possible as you can.
- Reduce handling of static-sensitive modules when necessary.
- Wear a grounded antistatic wrist strap to insulate the static voltage from your body while touching these modules.
- Operate static-sensitive modules only at static-free areas. Avoid handling modules in areas that allow anything capable of generating or holding a static charge.

Required Equipments

The equipments listed in the table are required to troubleshoot the multimeter.

Table 5-1 required equipments

Equipment	Critical Specifications	Example
Digital Multimeter	Accuracy $\pm 0.05\%$ 1 mV resolution	Siglent SDM3055

Power Board Drawing

Power Board mainly works on rectifiers. Please refer to the following drawing to quickly locate the test points on the analog board for easy resolution of the failures you encounter.

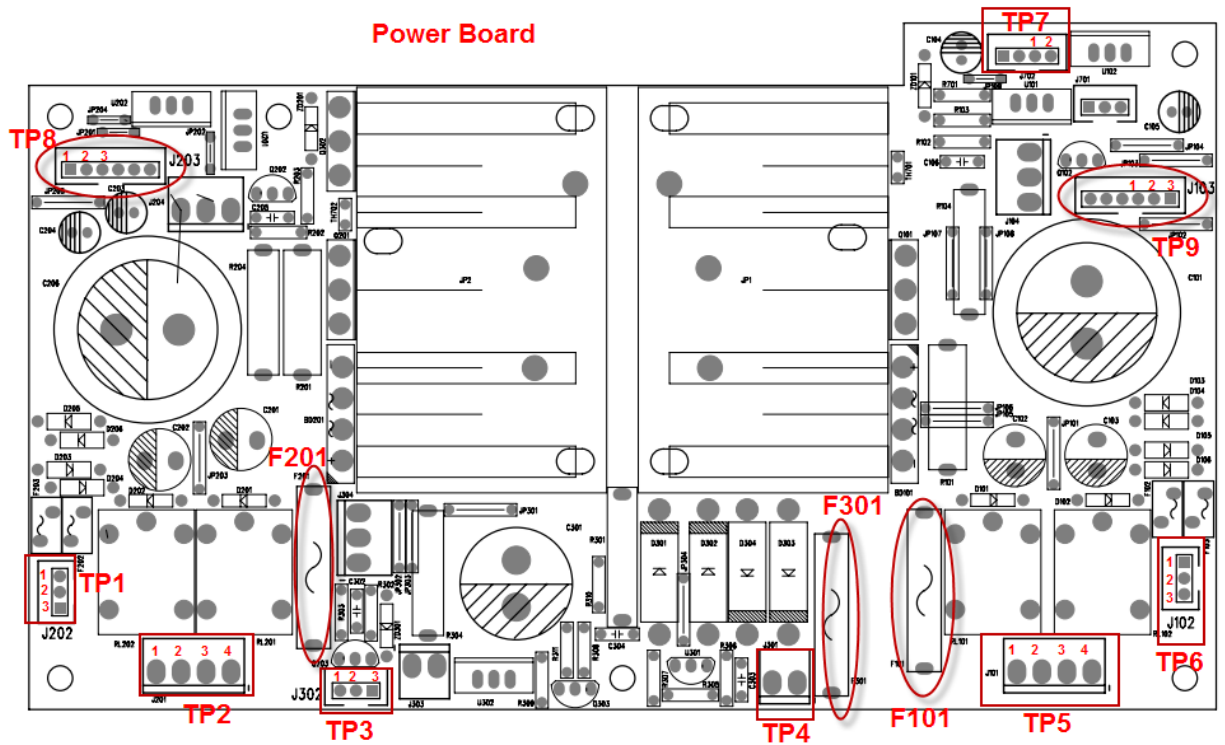

Main Board Drawing

Main board is used to control and manage the whole internal system of the Power Supply. It completes the GUI function, controlling and configuration function for power board as well as man-machine interaction. Please refer to the following drawing to quickly locate the test points on the main board for easy resolution of the failures you encounter.

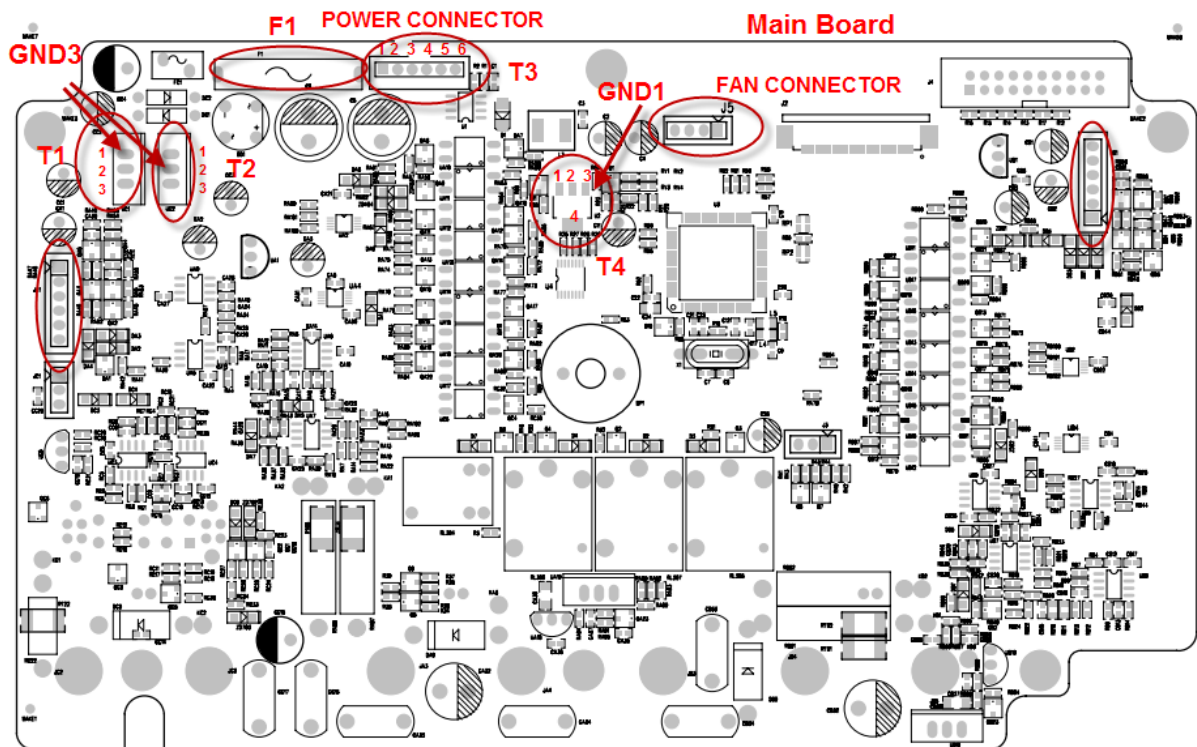

Check the Power Board

Here are procedures for testing the power board:

1. Several kinds of connectors including Fan Connector, Power Connector on the power board. Check if all these connectors are connected properly.
2. Make sure that the connectors on the power board are properly connected, then connect the SPD3303C to AC power and turn it on. Check if the voltage values at all test points are within the spec range using a digital multimeter. The voltage parameters to be tested are listed in table below:

Voltage Checking

Test the voltage points on the power board in the table below. If each tested voltage value is within the corresponding spec range referring to the table above, then the power board works normally. Otherwise, it proves to be faulted, please return it to the factory to have it repaired or contact SIGLENT.

Table 5-3 Test DC voltages of the power board

Test point	Name	Test pin	Voltage (V)	Error (V)
TP1	J202	1 to 2	19.2 VAC	±2
		3 to 2	19.2 VAC	±2
TP2	J201	1 to 4	34.9 VAC	±4
		2 to 4	21.3 VAC	±2.5
		3 to 4	7.2 VAC	±1
TP3	J302	3 to 2	+15 VDC	±0.5
TP4	J301	1 to 2	11.2 VAC	±1.5
TP5	J101	1 to 4	34.9 VAC	±4
		2 to 4	21.3 VAC	±2.5
		3 to 4	7.2 VAC	±1
TP6	J102	1 to 2	19.2 VAC	±2
		3 to 2	19.2 VAC	±2
TP7	J702	2 to 1	+8 VDC	±1
TP8	JP205	1 to 2	-15 VDC	±0.5
		3 to 2	+15 VDC	±0.5
TP8	JP103	1 to 2	+15 VDC	±0.5

		3 to 2	-15 VDC	±0.5
FUSE	F101	Good?		
	F201	Good?		
	F301	Good?		

I

Check the Main Board

Here are procedures for testing the main board:

1. Several kinds of connectors including Fan Connector and Power Connector are located on the main board. Check if all these connectors are connected properly.
2. Make sure that the connectors on the main board are properly connected, then connect the SPD3303C to AC power and turn it on. Check if the voltage values at all test points are within the spec range using a digital multimeter. The voltage parameters to be tested are listed in table below:

Voltage Checking

Test the voltage points on the main board in the table below. If each tested voltage value is within the corresponding spec range referring to the table above, then the main board works normally. Otherwise, it proves to be faulted, please return it to the factory to have it repaired or contact SIGLENT.

Table 5-4 Test DC voltages of the main board

Test point	Name	Pin	Voltage (V)	Error (V)
T1	UC1	3 to 1	-15 VDC	±0.5
T2	UC2	3 to 2	+15 VDC	±0.5
T3	J1	1 to 2	7.5 VAC	±1
		3 to 4	19 VAC	±2
T4	U2	1 to 3	+5 VDC	±0.5
		2 to 3	+3.3 VDC	±0.2
FUSE	F1	Good?		

Quick Guide for General Failures

The general hardware failures are described in the following. Reading the following information can help you quickly handle some easy hardware failures with more convenience.

1. No start-up after pressing the Power button:

- (1) Check if the power cord is correctly connected.
- (2) Check if the power button is usable.
- (3) Check whether the fuse has been burnt out. If the fuse needs to be changed, please contact SIGLENT as soon as possible and return the instrument to the factory to have it repaired by qualified personnel.
- (4) Check if the power connector is properly connected to the main board and power board.
- (5) If the instrument still does not work normally, please contact SIGLENT.

2. The instrument starts up with a dark screen:

- (1) Check if the power connector is properly connected to the main board.
- (2) If the instrument still does not work normally, please contact SIGLENT.

3. No response after pressing any button or abnormal display of the screen:

- (1) Check if the two end of the connector between the keypad circuit board and the main board is properly connected.
- (2) If the instrument still does not work normally, please contact SIGLENT.

Maintenance

Maintain Summary

SIGLENT warrants that the products it manufactures and sells are free from defects in materials and workmanship for a period of three years from the date of shipment from an authorized **SIGLENT** distributor. If a product proves defective within the respective period, **SIGLENT** will provide repair or replacement as described in the complete warranty statement.

To arrange for service or obtain a copy of the complete warranty statement, please contact your nearest **SIGLENT** sales and service office.

Except that as provided in this summary or the applicable warranty Statement, **SIGLENT** makes no warranty of any kind, express or implied, including without limitation the implied warranties of merchantability and fitness for a particular purpose. In no case shall **SIGLENT** be liable for indirect, special or consequential damages.

Repackaging for Shipment

If the unit needs to be shipped to **SIGLENT** for service or repair, be sure:

1. Attach a tag to the unit identifying the owner and indicating the required service or repair.
2. Place the unit in its original container with appropriate packaging material for shipping.
3. Secure the container with strong tape or metal bands.

If the original shipping container is not available, place your unit in a container which will ensure at least 4 inches of compressible packaging material around all sides for the instrument. Use static-free packaging materials to avoid additional damage to your unit.

Teléfonos / Phone number

Mex: +52 (33)-3854-5975
+52 (33)-3823-4349
USA: +1 (619) 619-7350

Página Web / Website

tienda.logicbus.com.mx
logicbus.com

Correo electrónico / E-mail

ventas@logicbus.com
sales@logicbus.com



Dirección / Address



Av. Fray Antonio Alcalde 1822
Miraflores, 44270
Guadalajara, Jal



8280 Clairemont Mesa Blvd
Suite 122
San Diego, CA 92111

