

CV-W124/P2102

24" TFT-LCD Modular Panel PC with 8th Gen. Intel® Core™ U Series Processor



- 24" Full HD TFT-LCD with Resistive 5-wire Touch / Projected Capacitive Touch / Glass Only
- Onboard 8th Generation Intel® Core™ U Series Processor
- 2x DDR4 SO-DIMM Socket, Supports Up to 2400MHz, 64GB
- Supports Triple Independent Display
- Integrated USB 3.2 Gen 2 supports up to 10Gbps
- M.2 E Key Socket for Wireless Module or Intel CRF Module
- Supports Ignition Sensing Function (IGN) (with optional CFM module)
- Supports 2x PoE+ Function (with optional CFM module)
- Designed with Rugged Aluminum Die-casting Front Bezel
- True Flat IP65 Compliant Front Panel Protection
- Supports Panel / VESA / Rack Mounting



Overview

The CV-W124/P2102 is a 24" TFT-LCD panel PC with Intel® 8th generation Core™ U Series Processor and is suitable for the high-performance requirement in factory and machine automation applications. The processor brings outstanding computing performance boost up to 84% at a TDP of 15 watts, compared to 6th generation Intel® Core™ U series. To enable faster responsiveness and deal with multi tasks with ease, the panel PC is equipped with two DDR4 2400 SODIMM sockets for up to 64 GB memory.

With its slim design, the CV-W124/P2102 offers extensive I/O to fulfill different connectivities and can easily fit into almost any space limited environment. For wireless connectivity, the CV-W124/P2102 has 1x M.2 2230 E key and 2x full-size Mini-PCIe expansions which can be installed various add-on cards to enable Wi-Fi, 3G, and LTE communication. Besides, the CV-W124/P2102 supports Control Function Module (CFM) Technology to install optional CFM modules for increasing power over ethernet and power ignition sensing functions according to user's specific applications. Featuring rigorous industrial protections, wide range operating temperature, IP65 dust/waterproof front panel, and wide range DC power input (9 to 48VDC), the CV-W124/P2102 is appropriate for harsh environments and critical industrial applications.

Furthermore, the CV-W124/P2102 supports Cincoze patented Convertible Display System (CDS) technology, allowing users to replace display module or computer module on-site easily and thereby reducing maintenance costs and downtime.

Highlights



4X Cores

High Performance Per Watt

Powered by 8th generation Intel® Core™ U series processor (up to 4 cores, 4.10 GHz) at a TDP of only 15W, the CV-W124/P2102 can fulfill a variety of applications that require high-performance computing and low power budget simultaneously.

**Thickness
67 mm**



Slim Design with Multiple Functions

The CV-W124/P2102 is designed at only 67 mm height and provides a wall-mount kit for easy installation in any space limited environment. Furthermore, a variety of I/O, 2x 2.5" SATA 3.0 drive bays, and M.2/mPCIe expansions are also available to fulfill multiple applications.



Patented CDS Technology

Thanks to Cincoze patented Convertible Display System (CDS) technology, the CV-W124/P2102 not only makes maintenance easier but also provides upgradability whenever requested.

Specifications

Display

- LCD Size: 24" (16:9)
- Max. Resolution: 1920 x 1080
- Brightness (cd/m2): 300
- Contrast Ratio: 5000 : 1
- LCD Color: 16.7M
- Pixel Pitch (mm): 0.27675 (H) x 0.27675 (V)
- Viewing Angle (H-V): 178 / 178
- Backlight MTBF: 50,000 hrs (LED Backlight)

Touch

- Resistive 5-wire Touch for CV-W124R/P2102 Only
- Projected Capacitive Touch for CV-W124C/P2102 Only

Processor System

- Onboard 8th Intel® Core™ U Processors (Whiskey Lake)
 - Intel® Core™ i5-8365UE Quad Core Processor (6M Cache, up to 4.10 GHz)
 - Intel® Core™ i3-8145UE Dual Core Processor (4M Cache, up to 3.90 GHz)
 - TDP: 15 W

Memory

- 2x DDR4 2400 MHz 260-Pin SO-DIMM Socket
- Supports up to 64 GB (un-buffered and non-ECC)

Graphics

- Integrated Intel® UHD Graphics 620
- Supports Triple Independent Display (via VGA and DisplayPort Outputs)

Audio Codec

- Realtek ALC888-GR

External I/O Interface

- 1x VGA (1920 x 1200 @60Hz)
- 1x DisplayPort (4096 x 2304 @ 60Hz)
- 2x GbE LAN (Supports WoL, Teaming, Jumbo Frame & PXE), RJ45
 - GbE1: Intel® I219-LM
 - GbE2: Intel® I210-IT
- 3x USB 3.2 Gen2 (Type A)
- 2x USB 2.0 (Type A)
- 4x RS-232/422/485 with Auto Flow Control (Supports 5V/12V), DB9
- 1x Speaker-out & 1x Mic-in, Phone Jack 3.5mm
- 1x ATX Power On/Off Button
- 1x Reset Button
- 1x AT/ATX Mode Switch
- 1x Clear CMOS Switch
- 1x Remote Power On/Off Connector, 2-pin Terminal Block
- 16x Isolated DIO (8x DI/8x DO), 20-Pin Terminal Block
- 1x Ignition DIP Switch (12V/24V, need to work with CFM module)

Storage

- 2x 2.5" HDD/SSD Drive Bay (SATA 3.0), Supports RAID 0/1

Expansion

- 2x Full-size Mini-PCIe Socket
- 1x M.2 2230 E Key for Socket Wireless Module, Supports Intel CRF Module
- 2x Control Function Module (CFM) Interface
- 1x Front Accessible SIM Socket
- 4x Antenna Hole

Other Functions

- Watchdog Timer: Software Programmable Supports 256 Levels System Reset
- Internal Speaker AMP 2W + 2W
- OSD Function: LCD On/Off, Brightness Up, Brightness Down
- SuperCap Integrated for CMOS Battery Maintenance-free Operation
- Supports Instant Reboot Technology (0.2 sec)

Power Requirement

- Supports AT/ATX Power Type
- Power Input Voltage 9~48VDC
- 1x 3-pin Terminal Block
- Power Adapter (Optional): AC/DC 24V/5A 120W

Physical

- Dimension (WxDxH, mm): 605 x 373 x 76 mm
- Weight: CV-W124R/P2102: 9.2 kg
CV-W124C/P2102: 8.9 kg
CV-W124G/P2102: 8.9 kg
- Construction: Rugged Aluminum Die-casting Front Bezel and Heavy Duty Metal Chassis
- Mounting: Panel / VESA / *Rack Mounting (*with optional mounting kit)
- Fanless Design
- Jumper-less Design

Environment

- Operating Temperature:
 - CV-W124R/P2102: -20°C to 70°C
 - CV-W124C/P2102: -30°C to 70°C
 - CV-W124G/P2102: -30°C to 70°C
 - (with Extended Temperature Peripherals; Ambient with Air Flow)
- Storage Temperature:
 - CV-W124R/P2102: -20°C to 70°C
 - CV-W124C/P2102: -30°C to 70°C
 - CV-W124G/P2102: -30°C to 70°C
- Relative Humidity: 80% RH @ 50°C (Non-condensing)
- Shock: Operating, 15 Grms, Half-sine 11 ms Duration (w/ SSD, according to IEC60068-2-27)
- Vibration: Operating, 1.5 Grms, 5-500 Hz, 3 Axes (w/ SSD, according to IEC60068-2-64)
- IP Level: IP65 Compliant Front Panel
- EMC: CE, FCC Class A

Protection

- Reverse Power Input Protection
- Over Voltage Protection: 58V
- Over Current Protection: 15A
- ESD Protection: +/-15kV (air), +/-8kV (contact)
- Surge Protection: 3.84 kV (impedance 12 ohm 1.2/50µs waveform)

Operating System

- Windows® 10
- Linux: Supports by project

External Layout

Front I/O

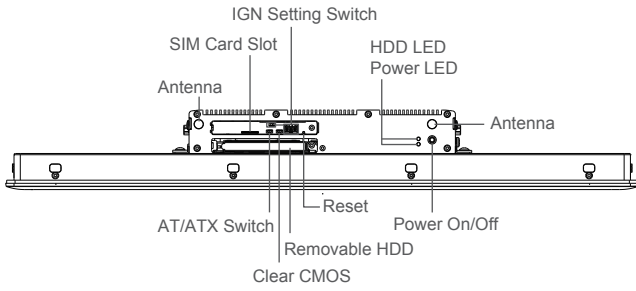

Rear I/O

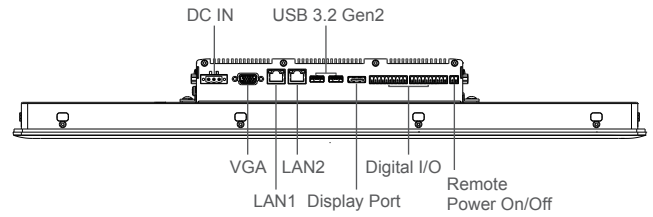

Left I/O

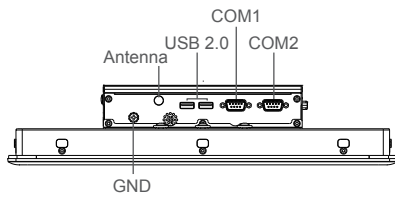

Right I/O

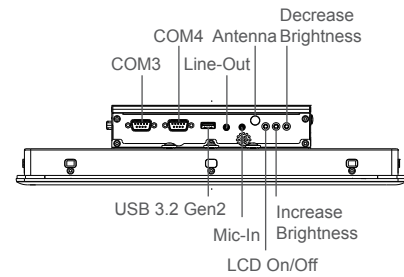

Dimensions

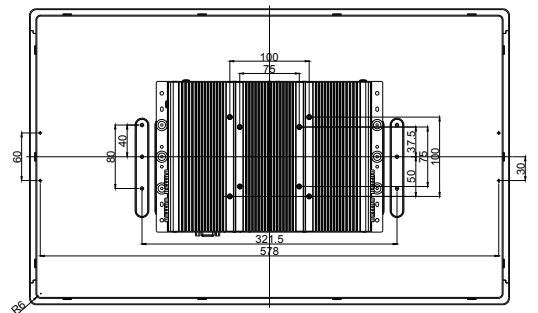
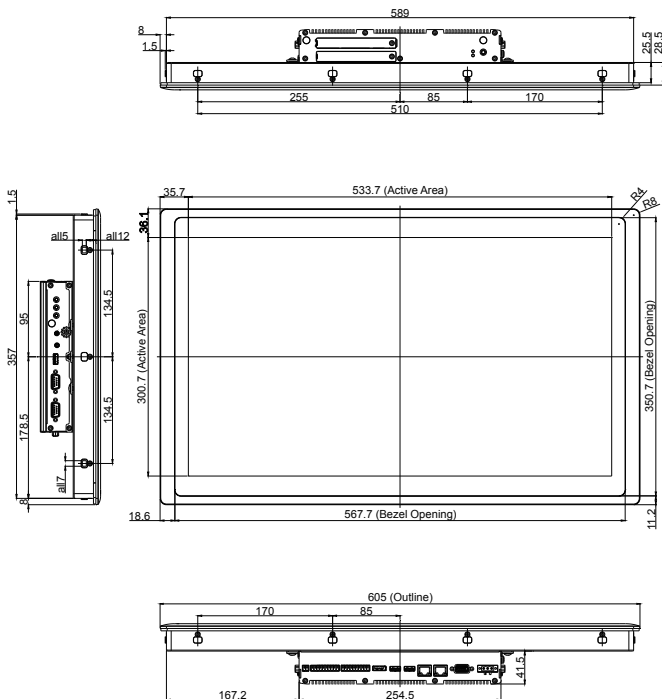

12 (Max. Wall Thickness)

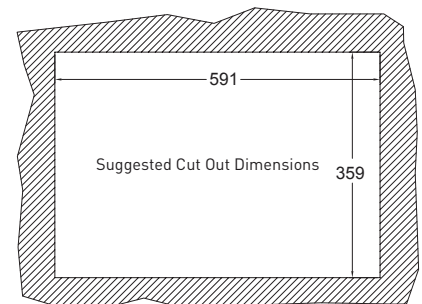

Unit: mm

Ordering Information

Available Models

Model No.	Description
CV-W124R-R10/P2102-i5-R10	24" Full HD TFT-LCD Modular Panel PC with 8th Gen. Intel Core i5-8365UE Quad Core Processor and Resistive Touch
CV-W124R-R10/P2102-i3-R10	24" Full HD TFT-LCD Modular Panel PC with 8th Gen. Intel Core i3-8145UE Dual Core Processor and Resistive Touch
CV-W124C-R10/P2102-i5-R10	24" Full HD TFT-LCD Modular Panel PC with 8th Gen. Intel Core i5-8365UE Quad Core Processor and P-Cap. Touch
CV-W124C-R10/P2102-i3-R10	24" Full HD TFT-LCD Modular Panel PC with 8th Gen. Intel Core i3-8145UE Dual Core Processor and P-Cap. Touch
CV-W124G-R10/P2102-i5-R10	24" Full HD TFT-LCD Modular Panel PC with 8th Gen. Intel Core i5-8365UE Quad Core Processor and Glass Only
CV-W124G-R10/P2102-i3-R10	24" Full HD TFT-LCD Modular Panel PC with 8th Gen. Intel Core i3-8145UE Dual Core Processor and Glass Only

Package Checklist

- CV-W124/P2102 Panel PC x 1
- Thermal Pad (for CPU Thermal Block) x 1
- Power Terminal Block Connector x 1
- Remote Power On/Off Terminal Block Connector x 1
- DIO Terminal Block Connector x 2
- Utility Driver DVD x 1
- Screws Pack x 5
- Panel Mounting Kit x 1

Optional Modules & Accessories

Model No.	Description
CFM-IGN101	CFM Module with Power Ignition Sensing Control Function, 12V/24V Voltage Detection Selectable
CFM-PoE04	CFM Module with PoE Control Function, Individual Port 25.5W
GST120A24-CIN	Adapter AC/DC 24V 5A 120W, GST120A24-CIN, wide temp (-30°C ~ +70°C), level VI
SL2-SL3	US 2 heads power cord, US B type to IEC C13, SVT 18AWG/3C Black 1.8M SL-2+SL-3
SL6-SL3	EU 2 heads power cord, EU G type to IEC C13, H05VV-F 0.75mm2/3G Black 1.8M SL-6+SL-3
QP026-SL3	UK 2 heads power cord, UK I type to IEC C13, H05VV-F 0.75mm2/3G Black 1.8M QP026+SL-3
URM01	Universal 19" Rack Mount Kit for Industrial Panel PC & Industrial Monitor