

DE-1000L

Intel® Atom™ E3845 Quad Core Power Efficient Fanless Computer with 6x LAN



Key Features

- Onboard Intel® Atom™ E3845 Processor Quad Core, 1.91GHz
- 2x DDR3L SO-DIMM Max. up to 8GB
- Dual Independent Display from 1x DVI-I and 1x DisplayPort
- 6x Intel® GbE Port, Support Wake-on-LAN and PXE
- 1x USB 3.0, 4x USB 2.0
- 6x RS232/422/485 Port with 5V/12V Power
- 4x Isolated DI, 4x Isolated DO
- 2x 2.5" SATA SSD/HDD Bay, 1x mSATA (Shared by Mini-PCIe Socket), 1x CFast Card and 1x SIM Card Socket
- 9~48VDC Power Input, Support AT/ATX Mode
- 2x Mini-PCIe Slot for Wi-Fi, GSM, or I/O Expansion
- Power Ignition
- Compliant with EN50155 for Rail Transportation Applications

Overview

DE-1000 Series Fanless Embedded PC supports Intel® Bay Trail platform, integrated with Intel® Atom™ E3845 Quad Core 1.91 GHz processor. Delivering the excellent quad-core processing power at only 10 watts power consumption, DE-1000 series is definitely an ideal solution for ultimate computing performance, energy efficiency, and superior reliability.

Designed with rich I/O, high flexibility and easy expansion capabilities, DE-1000 series is ideal for diverse industrial applications. It offers multiple I/O extension modules, including up to 2x PCI or 2x PCIe x1 slot for flexible integration of a variety of add-on cards; 2x mini-PCIe slot for GSM and WLAN wireless communication; it also supports three storage expansions: 2.5" SATA HDD, CFast and SIM card.

Supporting up to 6x LAN or 4x POE versions, and power ignition function, DE-1000 series can meet various applications, such as: surveillance, in-vehicle, and industrial automation applications, etc.

DE-1000 series supports wide temperature range from -25°C to 70°C, wide range (9~48V) DC power input, power protection, cable free and one-piece housing design, as well as compliant with EN50155 certification for rail transportation applications; it is designed to ensure stable operation in robust and harsh environments.

Specifications

Processor

- Onboard Intel® Atom™ Processor E3845 Quad Core, 1.91 GHz with AMI 64Mbit SPI BIOS.

Memory

- 2x 204-Pin DDR3L 1066 / 1333MHz SO-DIMM (un-buffered and non-ECC), Max. up to 8GB

Graphics

- Intel® HD Graphics Max. 792 MHz
- Support Dual Display
 - 1x DVI and 1x DisplayPort
 - 1x DVI-D and 1x VGA (with optional split cable)
 - 1x DisplayPort and 1x VGA (with DVI-I to VGA adapter)

Storage

- 2x 2.5" SATA HDD Bay
- 1x Internal mSATA Slot (Shared by Mini-PCIe Socket)
- 1x External CFast Socket
- 1x External SIM Card Socket

External I/O Interface

- 1x DVI-I
- 1x DisplayPort
- 2x GbE LAN Port (Intel® i210-IT, Support Wake-on-LAN and PXE)
- 4x GbE LAN Port (Intel® 82583V, Support Wake-on-LAN)
- 1x Mic-in and 1x Line-out (Codec: Realtek ALC888S)
- 1x USB 3.0 Port & 4x USB 2.0 Port
- 1x 4 Isolated DI & 4 Isolated DO Port
- 6x COM (DB9, RS232/422/485 with Auto Flow Control)
- 1x PS/2 Port
- 2x Antenna Hole
- 1x Power Switch
- 1x AT/ATX Switch
- 1x Remote Power Connector and Reset Connector

Expansion

- 2x Full-size Mini PCIe Socket for Wi-Fi / GSM / Expansion Module

Watchdog Timer

- Software Programmable Supports 256 Levels System Reset

Power Requirement

- Support AT/ATX Power Mode
- Power Input Voltage 9~48VDC
- One 3-pin Terminal Block Connector
- Optional Power Adapter AC/DC 12V/5A 60W

Physical

- Dimension: 203mm (W) x 200mm (D) x 65mm (H)
- Weight: 2.84 kg
- Construction: Aluminum Chassis with Fan-less Design
- Mounting: Wall Mounting
(Optional Side/VESA/DIN-Rail Mounting)
- Cable-less Design

Environment

- Operating Temperature: -25°C to 70°C (ambient with air flow; with Industrial Grade Peripherals)
- Storage Temperature: -30°C to 85°C
- Relative Humidity: 10%~95% (non-condensing)
- Shock: 50 Grms
(With SSD According to IEC 60068-2-27, Half Sine, 11ms Duration)
- Vibration: Random: 5 Grms
(With SSD According to IEC 60068-2-64, 5~500Hz, 1 hr/axis)

Digital Input & Output

- 4x Digital Input (Source Type)
 - Input Voltage (Dry Contact):
Logic 0: Close to GND
Logic 1: Open
 - Input Voltage:
Logic 0: 3V max.
Logic 1: 5V min. [DI to COM-]
- 4x Digital Output
 - Supply Voltage: 9~30VDC
 - Sink Current: 580 mA Max. Per Channel

Regulations

- CE
- EN 50155
- FCC Class A
- EN 50121-3-2

Operating System

- Windows® 10
- Windows® 8
- Windows® Embedded 8 Standard
- Windows® 7
- Windows® Embedded Standard 7
- Linux: Supports by Project

»» External I/O Mechanical Layout

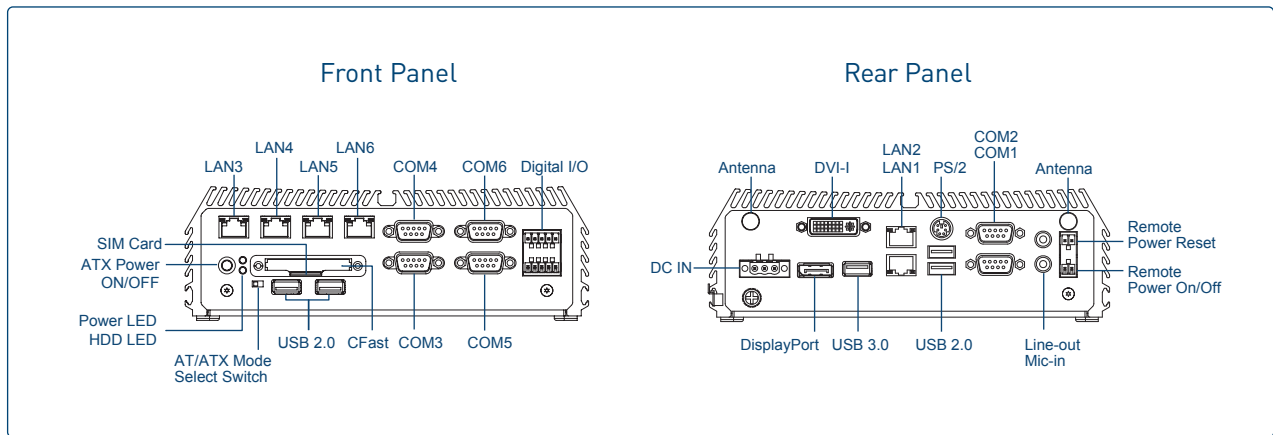

»» Dimensions

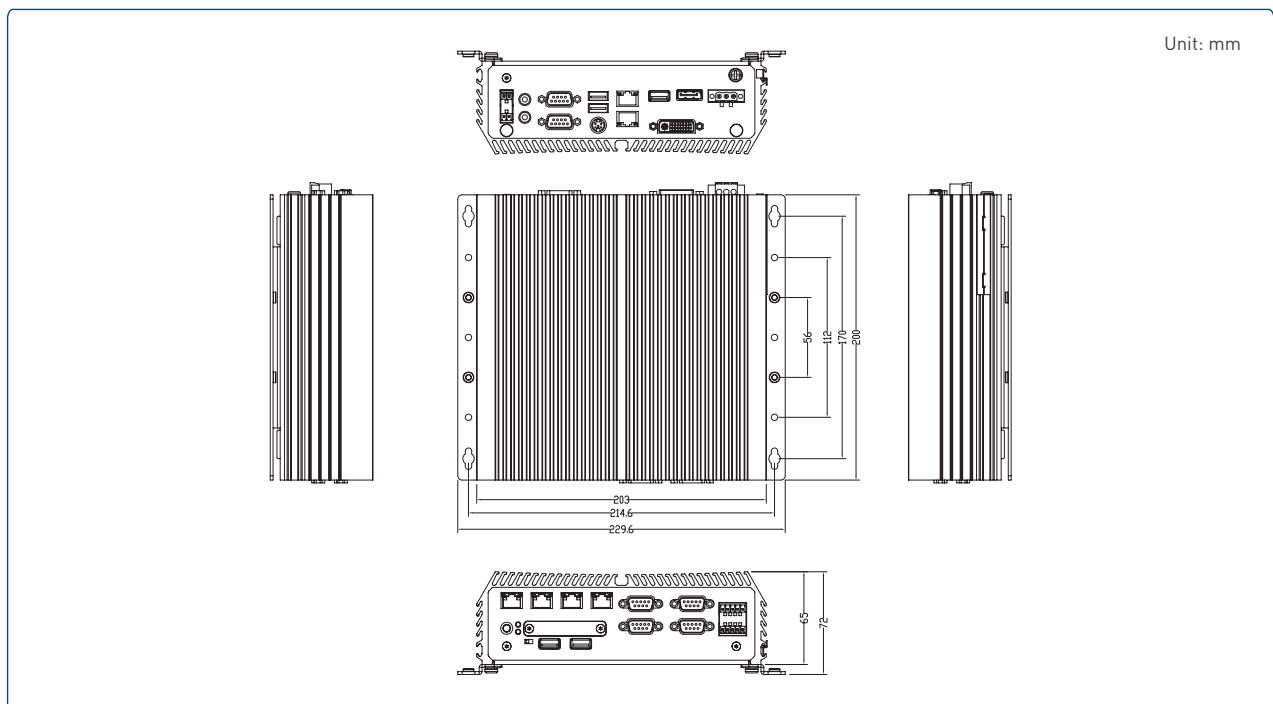

»»» Ordering Information

Available Models

Model No.	Product Description
DE-1000L	Intel® Atom™ E3845 Quad Core Power Efficient Fanless Computer with 6x LAN

Package Checklist

- DE-1000L Embedded System x 1
- Utility DVD Driver x 1
- DIO Terminal Block Connector x 2
- Power Terminal Block Connector x 1
- Remote Power Terminal Block Connector x 2
- DVI-I to VGA Adapter x 1
- Screw Pack x 1
- Wall Mount Kit x 1

Optional Accessories

Model No.	Description
GST60A12-CIN1	Adapter AC/DC 12V 5A 60W with 3pin Terminal Block Plug 5.0mm Pitch, Level VI
SL2-SL3	US 2 heads power cord, US B type to IEC C13, SVT 18AWG/3C Black 1.8M SL-2+SL-3
SL6-SL3	EU 2 heads power cord, EU G type to IEC C13, H05VV-F 0.75mm2/3G Black 1.8M SL-6+SL-3
QP026-SL3	UK 2 heads power cord, UK I type to IEC C13, H05VV-F 0.75mm2/3G Black 1.8M QP026+SL-3
VESA-DE	DE series VESA Mount Kit
SIDE-DE	DE series SIDE Mount Kit
DINRAIL	Diamond series DIN-RAIL Mount Kit