

## VP SERIES 430 MM

DENSO VP-Series robots are perfect for installations where operational space is limited. Their outstanding features include:

- z Excellent repeatability of  $\pm 0.02$  mm
- z Payloads up to 3 kg
- z 430-mm reach
- z Ultracompact design, with space-saving footprint of only 160 x 160 mm, facilitates integration in tight spaces
- z Floor- or ceiling-mount with no special hardware needed
- z Exceptionally light weight from only 13 to 24 kg
- z Space-saving bottom-side cable connection (VP-G2)
- z Low energy consumption, with motors combined using a maximum of only 300 W
- z ANSI and CE compliance allows global deployment
- z UL models available for the US and Canada (VP-G2)



VP-5243G



VP-6242G



CEILING-MOUNT OPTION



		VP-5243G	VP-6242G	VP-6242G2	VP-6242G2-UL
Number of axes		5		6	
Overall arm length (mm)		430		420	
Second-arm width (mm)		112		122	
Reach (to center of 5th axis, mm)		430		432	
Minimum motion area (mm)		162		148	
Maximum payload (kg)		2.5 (3.0 with flange pointing down)	2.0 (2.5 with flange pointing down)	2.0	
Weight, approx. (kg)		13	15	24	
Footprint (mm)		160 x 160		200 x 200	
Cycle time (sec.)		0.99 (with 1-kg weight)			
Maximum composite speed (mm/sec.)		3,900			
Maximum joint speed (°/sec.)		J1: 250 J2: 187 J3: 250 J4, J5, J6: 300			
Repeatability <sup>2</sup> (mm)		$\pm 0.02$		$\pm 0.02$	
Max. allowable moment of inertia (kgm <sup>2</sup> )	J4	-		0.03	
	J5	0.04			
	J6	0.01		0.007	
Range of motion (°)	J1		$\pm 160$		
	J2		$\pm 120$		
	J3	+136, -128		+160, +19	
	J4	-		$\pm 160$	
	J5		$\pm 120$		
	J6		$\pm 360$		
Position detection		Absolute encoder			
Drive motors and brakes		AC servomotors and brakes for all axes			
Air piping (in-arm integrated)		4 systems ( $\phi 4 \times 4$ )			
Wiring (in-arm integrated)		9 lines (max. 1 A per line)		16 lines (max. 1 A per line)	
Air source	Operating pressure	$1.0 \times 10^5$ Pa to $3.9 \times 10^5$ Pa			
	Maximum allowable pressure	$4.9 \times 10^5$ Pa			
Protection class		IP30			
Ceiling-mount				-	-

1. At constant ambient temperature in every direction.

# VP SERIES 430 MM

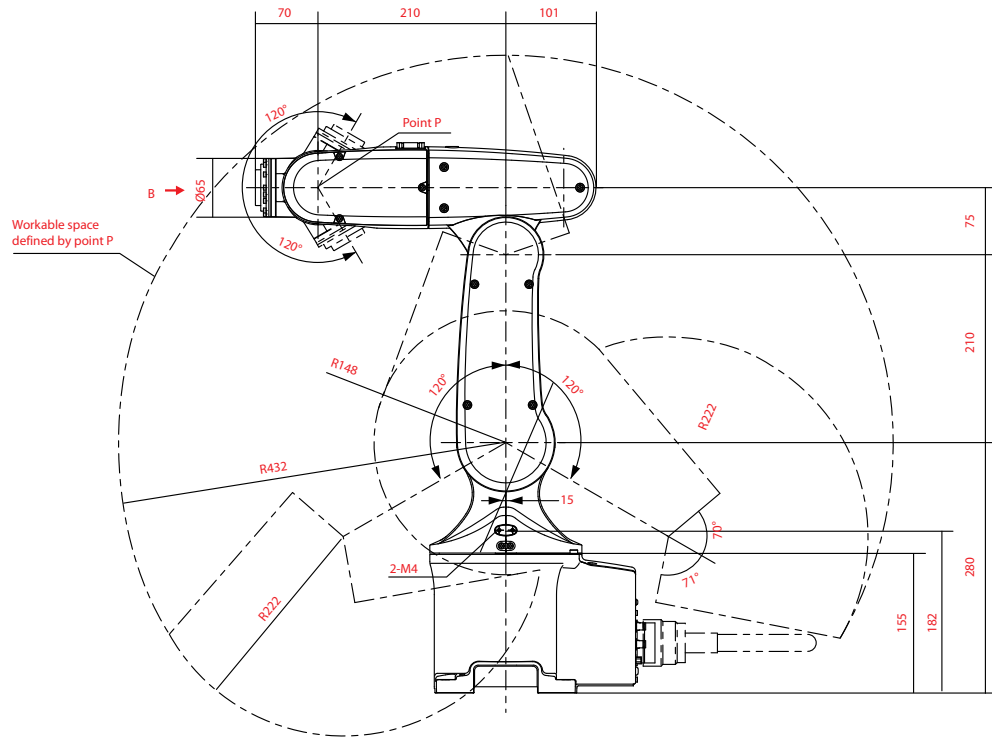

Unit: mm

Detail of end-effector mounting face (view A)

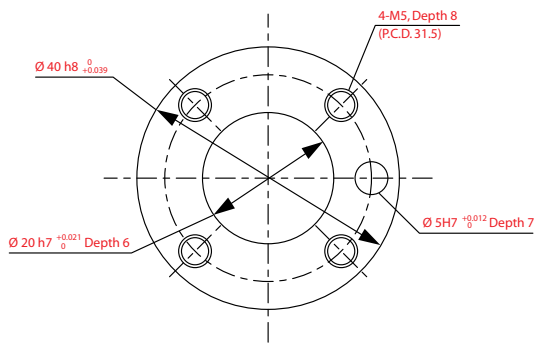

Detail of base mounting face (top view)

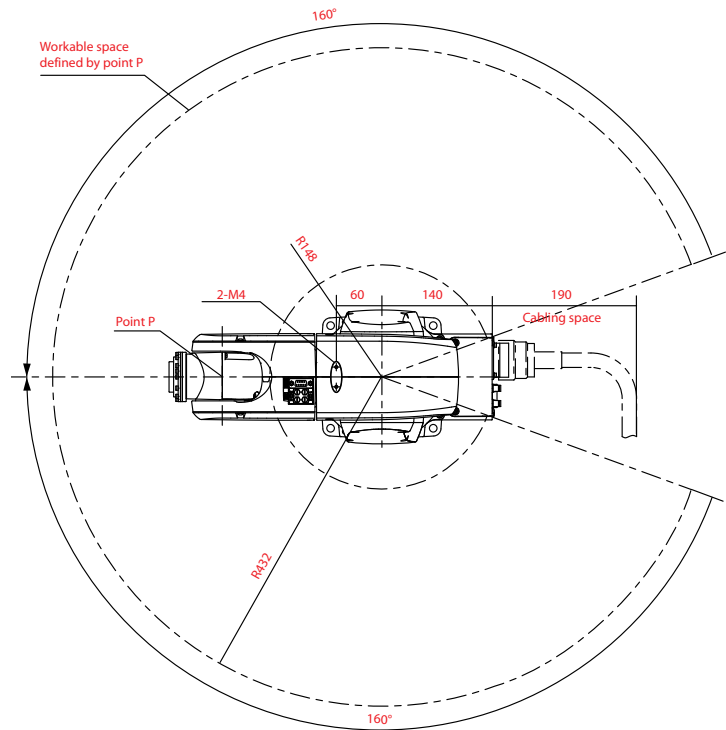
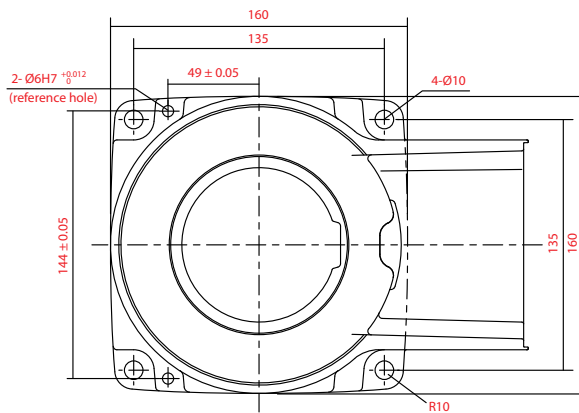

**DENSO**  
robotics