

FBs-6AD

6 Channel A/D Input Module



Introduction

FBs-6AD is one of the analog input modules of FATEK FBs series PLC. It provides 6 channels A/D input with 12 or 14 bit effective resolution.. Base on the different jumper settings it can measure the varieties of current or voltage signal. The reading value is represented by a 14 bit value no matter the effective resolution is set to 12 or 14 bit. In order to filter out the field noise imposed on the signal, it also provides the average of sample input function.

Dimensions

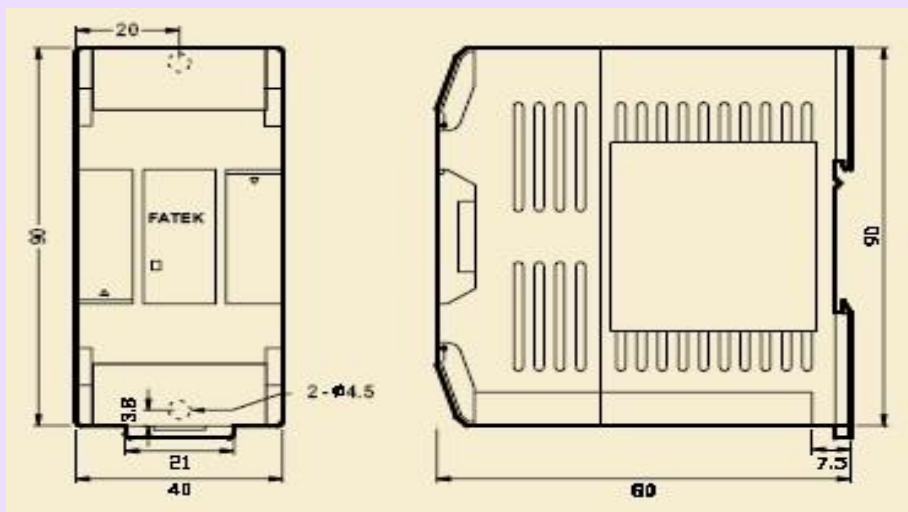

Specifications

Total Channels - 6 CH

Resolution- 14 or 12 bit

Signal Resolution - 0.3mV(Voltage), 0.61uA(Current)

I/O Points Occupied - 6 RI(Input Register)

Conversion Time- Updated each scan

Accuracy- $\pm 1\%$

Max. Absolute Input Rating-

$\pm 15V$ (Voltage), 30mA(Current)

Software Filter- Moving average

Average Samples- 1~16 configurable

Input Impedance- 63.2K Ω (Voltage), 250 Ω (Current)

Measurement Range-

-10~+10V, -5~+5V, 0~10V, 0~5V

-20~+20mA, -10~+10mA, 0~20mA, 0~10mA

Isolation- Transformer(Power) and photo-coupler(Signal)

Indicator(s) - 5V PWR LED

Supply Power- 24V-15%/+20%, 2VA

Internal Power Consumption- 5V, 100mA

Operating Temperature- 0 ~ 60 °C

Storage Temperature- -20 ~ 80 °C

Dimensions- 40(W)x90(H)x80(D) mm

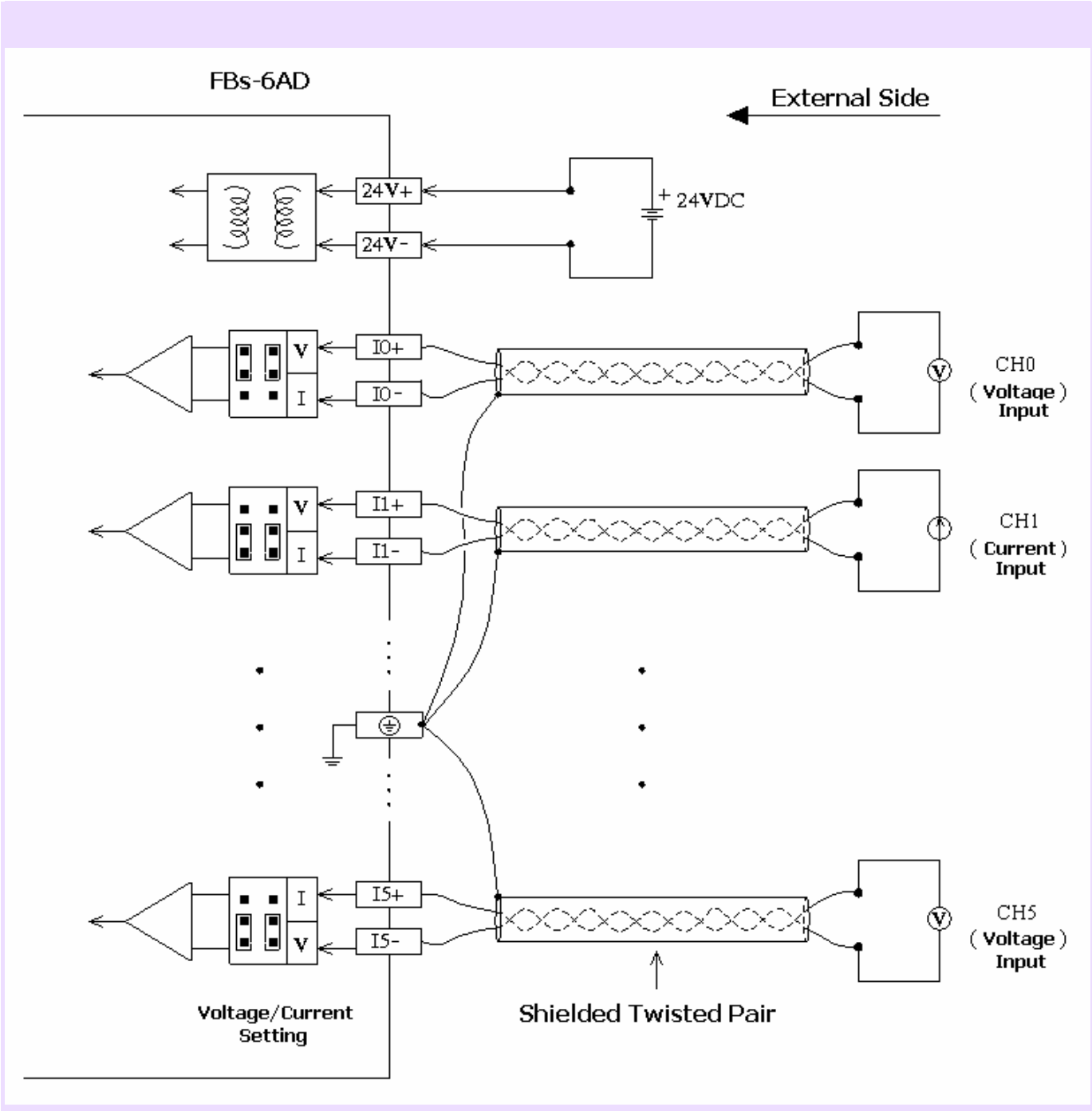

Wiring Diagram



Jumper Setting

Input Code Format Selection

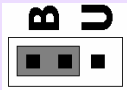
There are two input data formats can be selected which are bipolar and unipolar. The range of input value is 0~16383 for unipolar format while bipolar is -8192~+8191. The two extreme values of each range corresponding to the minimal and maximal input signal. For example, if chose the -10V~+10V type signal, for 10V input signal the input value is 16383 for unipolar format while the bipolar format is 8191. Normally the input code format setting is consistent with input signal type (bipolar coded for bipolar input signal, unipolar coded for unipolar input signal). Only when use the FUN32 for offset conversion should set the bipolar code for unipolar input signal (Please refer the FUN32 description). The code format of all input channels are set by the same JP1 jumper. The location and the setting of jumper of JP1 are shown at below

Code Format	Value Range	JP1 Setting
Bipolar	-8192 ~ +8191	
Unipolar	0 ~ 16383	

JP1

Input Signal Type setting

The current or voltage type setting of each channel can be set individually while the range and polarity setting share the same jumpers. All locations of jumper for input signal type setting are shown at below

	JP4(CH0)
	JP5(CH1)
	JP3(Common)
	JP2(Common)
JP7(CH3)	JP8(CH4)
JP6(CH2)	JP9(CH5)

Range (JP2) and polarity (JP3) setting

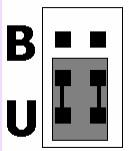
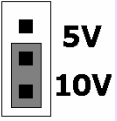
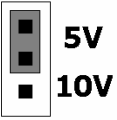
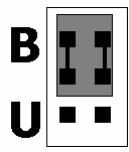
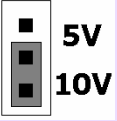
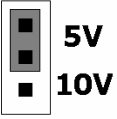
Signal Type	JP3 setting	JP2 setting
0~10V or 0~20mA		
0~5V or 0~10mA		
-10V~10V or -20mA~+20mA		
-5V~+5V or -10mA~+10mA		

CH0~CH5 share the JP2 and JP3 jumper, therefore all channels must be of the same type that is one of the four types listed at above table. Only the current/voltage setting can be chosen arbitrary.

Current/Voltage Mode Setting

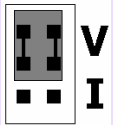
Signal Type	JP4(CH0)/JP5(CH1)/JP6(CH2)/JP7(CH3)/JP8(CH4)/JP9(CH5)setting
Current	 V I
Voltage	 V I

The default factory settings of 6AD analogue input module are

Input code format – Bipolar(-8192~+8191)

Input signal type and range – Bipolar(-10V ~ +10V)

For those applications that require the setting differ than the above default setting should make some modifications of jumper position according to above tables.

While application, besides the setting of jumper should be conducted, the AI module configuration of Winproladder also need to be performed.