

FATEK[®] AUTOMATION CORPORATION

26FL., NO. 29, SEC. 2, ZHONGZHENG E. RD.,
TAMSUI DIST., NEW TAIPEI CITY 25170, TAIWAN, R.O.C

TEL +886-2-2808-2192

FAX +886-2-2809-2618

E-mail sales@fatek.com

tech@fatek.com

Website www.fatek.com

AC SERVO
SD3 SERIES



A 50W motor and a 100W motor became more compact.^(*1)

M5G series

The Compact-Motor

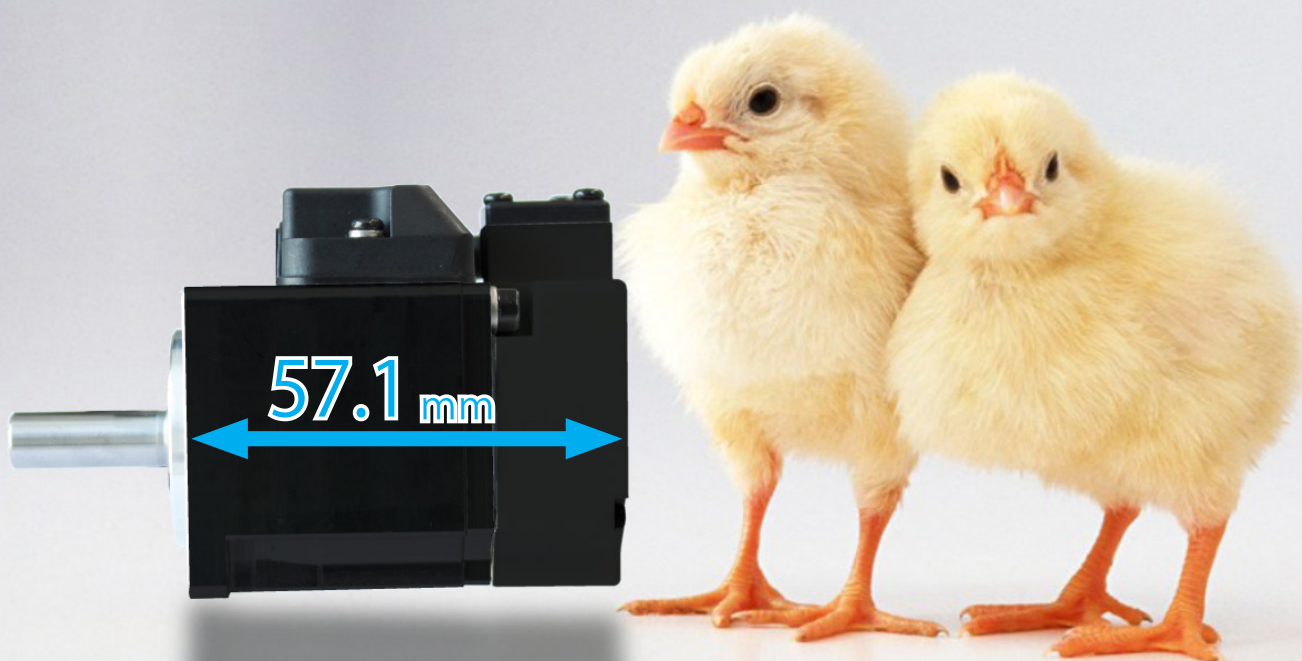

(The motor in this picture is "M5G005 □□ N □□ ***".)

Has a Great Value.

*1) About 15 % has been shortened compared with the body full length of previous M5B005 series and M5B010 series.

CONTENTS

PAGE

INTRO. Features » 4

01 Motor Models » 6

02 Motor Specifications » 8

03 Encoder Specifications » 23

04 Amplifier Models » 24

05 Amplifier Specifications » 25

06 Amplifier Dimensions » 27

07 Wiring » 29

08 Connectors » 35

09 Cables » 40

10 I/O Connections » 44

11 Safety Precautions » 49



HANDLING ROBOT

PRINTER

LASER BEAM MACHINE

MILLING MACHINE

PRESSING MACHINE

ELECTRIC DISCHARGE
MACHINES

PALLETIZER

DEVICES

TEXTILE MACHINERY

A wide range of customers have found SD3 invaluable for many industrial equipment and machinery needs. SD3 is now being applied in semiconductor manufacturing machines, processing machines, printing machines, textile machines, a large variety of automation machinery, as well as for LED panel-handling robots.



Inheriting State-of-the-Art Technology for Robot Control — Robust Control

The SD3 Servo Amplifier is equipped with servo control which takes advantage of our expertise in LCD and semiconductor robotics. Decoupling command responsiveness and disturbance compensation using observer-based model matching and feedforward, our Servo Amplifier offers control for two degrees of freedom.

Even under load fluctuations, you can expect smooth motion without needing to change tuning parameters. This control method is ideal for applications with high rigidity such as ball drives, where you will experience excellent command responsiveness.

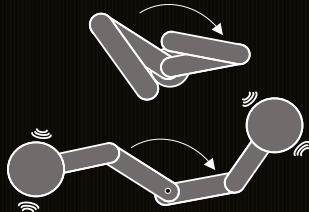

【Robust Control】

Robust Control is a control method which maintains expected robustness and stability even when the actual specifications of robots are slightly different from the initially intended control model.



ROBOT CONTROL



Ultimate Toughness and Low Current Consumption — Magnetic Absolute Encoder

No other type of encoder matches the ultimate toughness of the magnetic rotary encoder - which is its greatest advantage. Magnetic rotary encoders are resistant to oil and dust, and exhibit robust power in harsh production environments. SD3 original 1 pole magnetic absolute encoder has a straightforward, hard-to-break structure, and its resolution is comparable to optical encoders. Our new encoder is your one-stop solution for the ever-challenging threesome of goals: "toughness in harsh environments", "resolution", and "cost".

Also, our encoder features battery-free single-turn absolute position detection.

Furthermore, its current consumption upon battery backup is among the lowest in the industry.



Backup Current Consumption
The industry's lowest level of $10\mu A$



Per in-house testing, our current consumption is less than a half of that used by a standard absolute encoder.

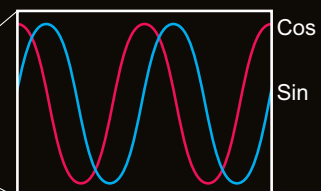
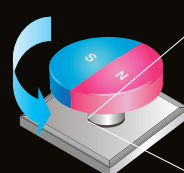

MAGNETIC ENCODER



Learning in the Field and Constantly Evolving — Amplifier Performance

Our new stronger damping filter helps your machine better suppress machine tip wobbles. With the newly developed “ γ -notch” filter, you may flexibly set responsiveness in frequency ranges higher than the notch frequency. Our new Servo offers shorter settling time for positioning, while maintaining the same damping features as before.

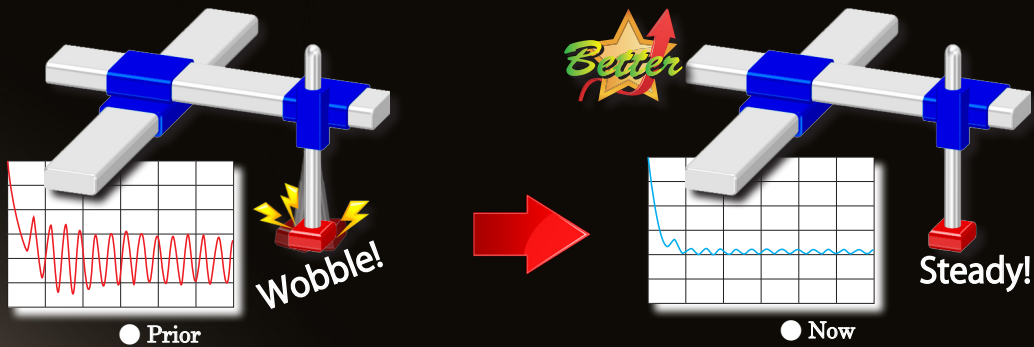

PROGRESSION



Specialized Tool Based on Ergonomics — Servo Studio

Servo studio is a powerful Software that eases setup, tuning, state monitoring, and effective use of SD3 Servo Amplifier. Now with its enhanced features, Servo studio is even more user-friendly and powerful.

With the greatly enhanced functionality, you can now setup our new damping filter from the intuitive interface, use an additional function “vibration noise frequency measurement (FFT)”, and get a log of the amplifier alarm.

In addition, smooth startup of your machine is facilitated through an amplifier point table (that can be set up to 16 points), and the test run features.

SOFTWARE

01 MOTOR MODELS

Low Inertia



200W **400W**

P.12

P.14

750W

P.16

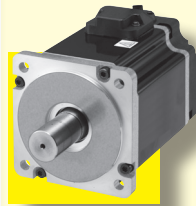
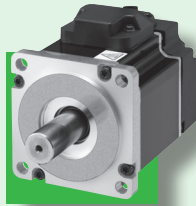

Middle Inertia



50W **100W**

P. 8, 9

P.10, 11



1kW **1.5kW** **2kW**

P.18

P.20

P.22

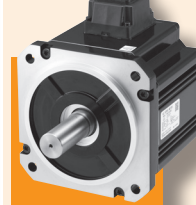

High Inertia



200W **400W**

P.13

P.15

750W

P.17

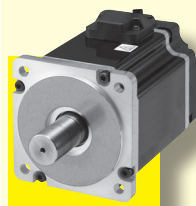
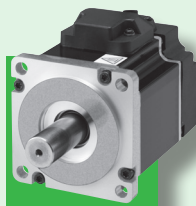

1kW **1.5kW**

P.19

P.21

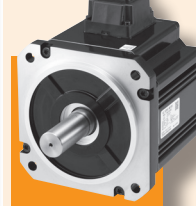

Inertia



Low Inertia



Middle Inertia



High Inertia

Flange Size



40 mm x 40 mm



60 mm x 60 mm



80 mm x 80 mm



130 mm x 130 mm

Rotational Speed



Rated Motor Speed / Max. [r/min]
2,000 / 3,000 [r/min]



3,000 / 6,000 [r/min]

IP Code



IP65



IP67

01 MOTOR MODELS

Features

Suitable for applications with high speed rotations
Can be used for most applications

Use Applications

Embroidery Machine
Textile Machine
Packaging Machine etc.

Features

Suitable for applications with low mechanical rigidity such as drive belt machinery

Use Applications

Removal Robot
Conveyer Machine
Processing Machine

Features

Suitable for applications with low mechanical rigidity such as drive belt machinery

Use Applications

Removal Robot
Conveyer Machine
Processing Machine

Model Number

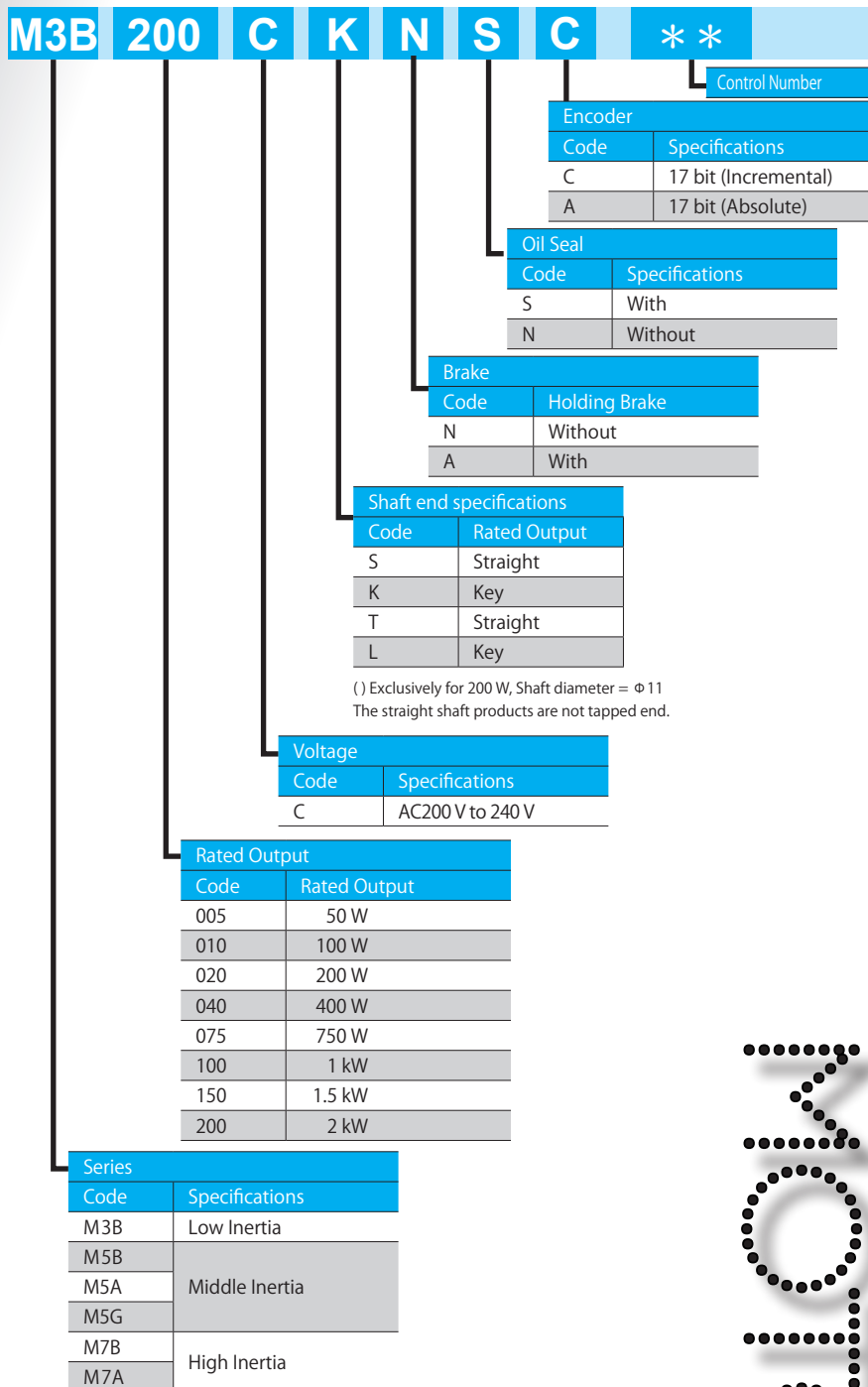

Installing Precautions

- Never remove the encoder or dismantle the motor body.
- The motor shaft has anti-rust oil applied at the shipment. Please wipe off the oil before installing the motor.
- Make sure to perform centering (alignment) carefully and properly.
- Operating the motor without sufficient alignments might cause vibrations or a shorter service life of the motor.

Connecting with a Mechanical System

- When connecting the motor to a load, use a coupling to absorb misalignments so that the motor shaft load remains within the rated load to the motor shaft.
- Improper use may cause a shorter service life of the motor bearing and damage the shaft.
- We recommend the use of flexible couplings.

Installation Orientations and Oil Seals

- The motor can be installed either vertically or horizontally. Please observe the following precautions.
 - Horizontal installation: Face the cable pull unit down in order to protect the motor against oil, water and dust.
 - Vertical installation : For a motor combined with a decelerator being on top of the motor shaft, use an oil sealed motor to prevent the decelerator oil from seeping into the motor.

Specifications

Motor Model : M5B005C □□□□* *

50W

40 SQUARE

F5

60-30

IP 65

Basic Specifications

Item	Unit	Specifications	
Rotor inertia	-	Middle	
Fitting flange size	mm	40 sq.	
Approximate mass	Without brake	kg	0.4
	With brake		0.6
Compatible amplifier model	-	SD3005CY**	
Voltage	V	AC200 V to 240 V	
Rated output	W	50	
Rated torque	N·m	0.16	
Instantaneous maximum torque	N·m	0.56	
Rated current	A	0.68	
Instantaneous maximum current	A	2.4	
Rated speed	r/min	3,000	
Maximum speed	r/min	6,000	
Torque constant	N·m/A	0.25	
Voltage constant-KE	mV/(r/min)	8.8	
Rated power	Without brake	kW/s	6.5
	With brake		5.4
Mechanical time constant	Without brake	ms	1.92
	With brake		2.31
Electrical time constant	ms	0.74	
Rotor moment of inertia	Without brake	$\times 10^{-4} \text{kg} \cdot \text{m}^2$	0.039
	With brake		0.047

Brake Specifications

Item	Unit	Specifications
Usage	-	Holding
Rated voltage	V	DC 24 V \pm 10 %
Rated current	A	0.25
Static friction torque	N·m	≥ 0.16
Pull-in time	ms	≤ 35
Release time	ms	≤ 20
Release voltage	V	$\geq \text{DC } 1 \text{ V}$

Allowable load

Item	Unit	Specifications
Radial	N	68
Thrust	N	58

Torque Characteristics

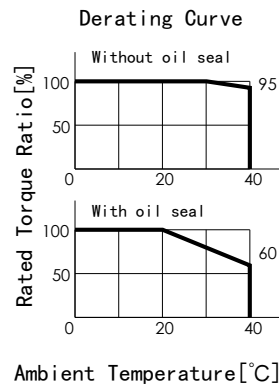
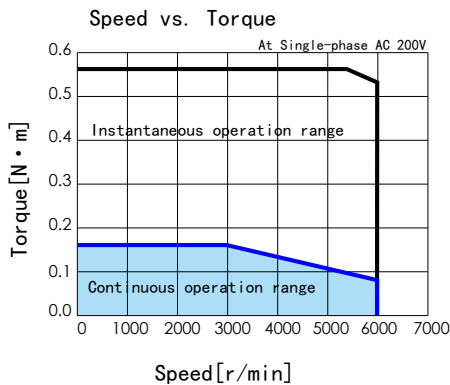

External Dimensions

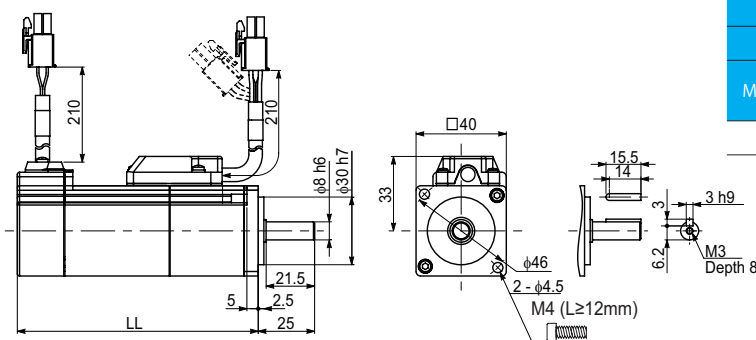

(mm)

Brake	Without		With	
	Without	With	Without	With
Oil Seal				
Motor Model	M5B005C*NN	M5B005C*NS	M5B005C*BN	M5B005C*BS
LL	66.4	72.0	106.8	112.4

The straight shaft products are not tapped end.

Specifications

Motor Model : M5G005C □□□□ * *



Basic Specifications

Item	Unit	Specifications	
Rotor inertia	-	Middle	
Fitting flange size	mm	40 sq.	
Approximate mass	Without brake	kg	0.4
	With brake	kg	0.6
Compatible amplifier model	-	SD3005CY**	
Voltage	V	AC200 V to 240 V	
Rated output	W	50	
Rated torque	N·m	0.16	
Instantaneous maximum torque	N·m	0.56	
Rated current	A	0.68	
Instantaneous maximum current	A	2.4	
Rated speed	r/min	3,000	
Maximum speed	r/min	6,000	
Torque constant	N·m/A	0.25	
Voltage constant-KE	mV/(r/min)	8.8	
Rated power	Without brake	kW/s	6.6
	With brake		5.4
Mechanical time constant	Without brake	ms	2.02
	With brake		2.45
Electrical time constant	ms	0.65	
Rotor moment of inertia	Without brake	$\times 10^{-4} \text{kg} \cdot \text{m}^2$	0.039
	With brake		0.047

Brake Specifications

Item	Unit	Specifications
Usage	-	Holding
Rated voltage	V	DC 24 V \pm 10 %
Rated current	A	0.25
Static friction torque	N·m	≥ 0.16
Pull-in time	ms	≤ 35
Release time	ms	≤ 20
Release voltage	V	$\geq \text{DC } 1 \text{ V}$

Allowable load

Item	Unit	Specifications
Radial	N	68
Thrust	N	58

Torque Characteristics

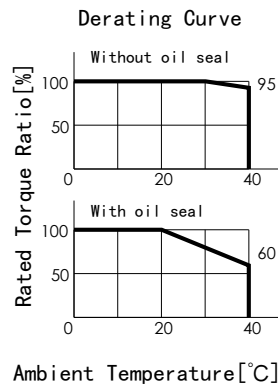
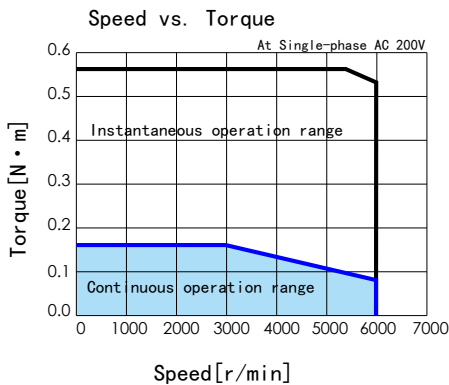

External Dimensions

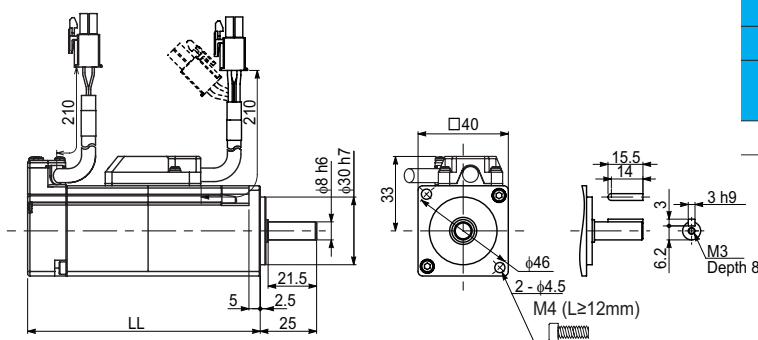

(mm)

Brake	Without		With		
	Oil Seal	Without	With	Without	With
Motor Model	M5G005C*NN	M5G005C*NS	M5G005C*BN	M5G005C*BS	
LL	57.1	64.7	89.5	97.1	

The straight shaft products are not tapped end.

MOTOR SPECIFICATIONS

02 M5B010 100W Middle Inertia

Specifications

Motor Model : M5B010C □□□□* *

100W

40
FLANGE

15
mm

60
30-0

IP
65

Basic Specifications

Item	Unit	Specifications	
Rotor inertia	-	Middle	
Fitting flange size	mm	40 sq.	
Approximate mass	Without brake	kg	0.5
	With brake		0.8
Compatible amplifier model	-	SD3010CZ**	
Voltage	V	AC200 V to 240 V	
Rated output	W	100	
Rated torque	N·m	0.32	
Instantaneous maximum torque	N·m	1.12	
Rated current	A	0.97	
Instantaneous maximum current	A	3.3	
Rated speed	r/min	3,000	
Maximum speed	r/min	6,000	
Torque constant	N·m/A	0.35	
Voltage constant-KE	mV/(r/min)	12.3	
Rated power	Without brake	kW/s	16.5
	With brake		14.6
Mechanical time constant	Without brake	ms	1.17
	With brake		1.32
Electrical time constant	ms	0.89	

Brake Specifications

Item	Unit	Specifications
Usage	-	Holding
Rated voltage	V	DC 24 V ± 10 %
Rated current	A	0.25
Static friction torque	N·m	≥ 0.32
Pull-in time	ms	≤ 35
Release time	ms	≤ 20
Release voltage	V	≥ DC 1 V

Allowable load

Item	Unit	Specifications
Radial	N	68
Thrust	N	58

Torque Characteristics

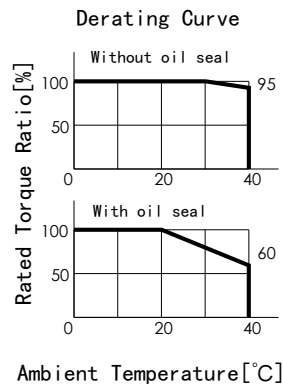
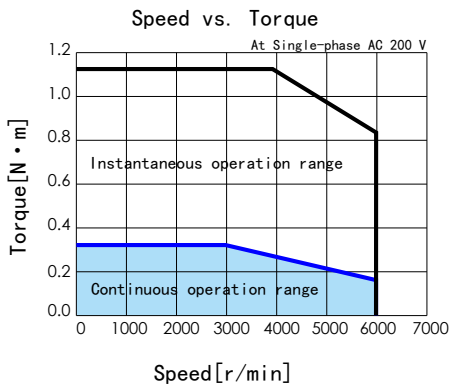

External Dimensions

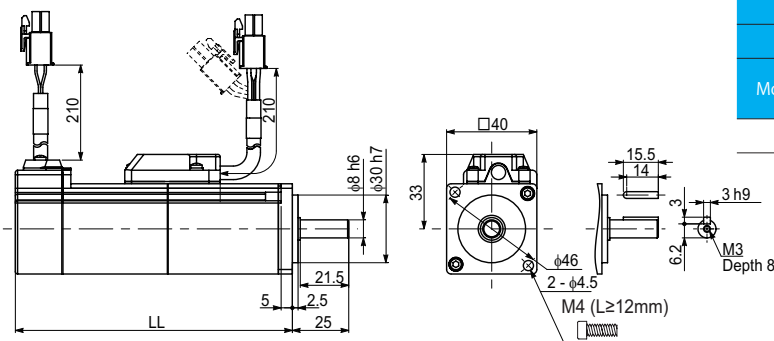

(mm)

Brake	Without		With		
	Oil Seal	Without	With	Without	With
Motor Model	M5B010C*NN	M5B010C*NS	M5B010C*BN	M5B010C*BS	
LL	82.4	88.0	122.8	128.4	

The straight shaft products are not tapped end.

MOTOR SPECIFICATIONS

02 M5G010 100W Middle Inertia

Specifications

Motor Model : M5G010C □□□□ * *

100W

40 SQUARE

F5

60-30

IP65

Basic Specifications

Item	Unit	Specifications
Rotor inertia	-	Middle
Fitting flange size	mm	40 sq.
Approximate mass	Without brake	kg
	With brake	0.5
Compatible amplifier model	-	SD3010CZ**
Voltage	V	AC200 V to 240 V
Rated output	W	100
Rated torque	N·m	0.32
Instantaneous maximum torque	N·m	1.12
Rated current	A	0.93
Instantaneous maximum current	A	3.3
Rated speed	r/min	3,000
Maximum speed	r/min	6,000
Torque constant	N·m/A	0.35
Voltage constant-KE	mV/(r/min)	12.3
Rated power	Without brake	kW/s
	With brake	
Mechanical time constant	Without brake	ms
	With brake	
Electrical time constant	ms	0.78
Rotor moment of inertia	Without brake	$\times 10^{-4} \text{kg} \cdot \text{m}^2$
	With brake	

Brake Specifications

Item	Unit	Specifications
Usage	-	Holding
Rated voltage	V	DC 24 V \pm 10 %
Rated current	A	0.25
Static friction torque	N·m	\geq 0.32
Pull-in time	ms	\leq 35
Release time	ms	\leq 20
Release voltage	V	\geq DC 1 V

Allowable load

Item	Unit	Specifications
Radial	N	68
Thrust	N	58

Torque Characteristics

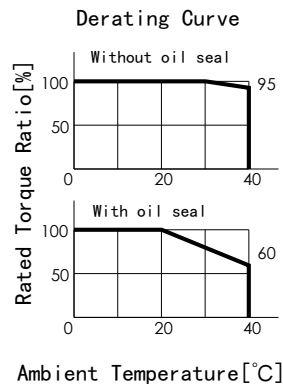
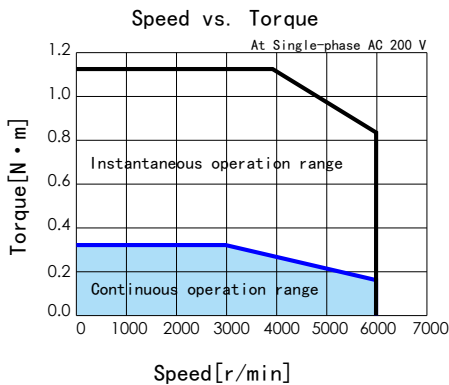

External Dimensions

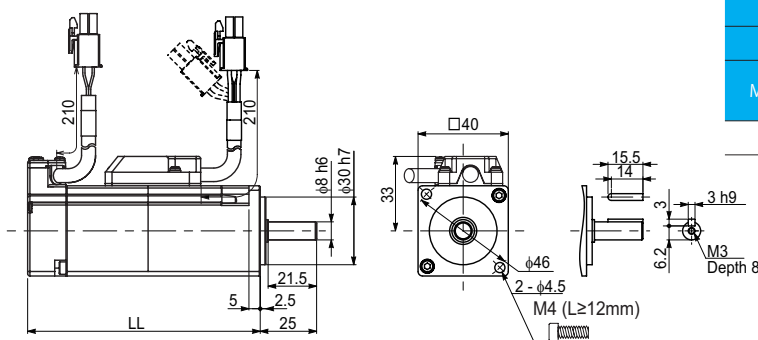

(mm)

Brake	Without		With	
	Without	With	Without	With
Oil Seal				
Motor Model	M5G010C*NN	M5G010C*NS	M5G010C*BN	M5G010C*BS
LL	70.7	78.3	103.1	110.7

The straight shaft products are not tapped end.

Specifications

Motor Model : M3B020C □□□□* *



Basic Specifications

Item	Unit	Specifications	
Rotor inertia	-	Low	
Fitting flange size	mm	60 sq.	
Approximate mass	Without brake	kg	0.8
	With brake		1.3
Compatible amplifier model	-	SD3020C1**	
Voltage	V	AC200 V to 240 V	
Rated output	W	200	
Rated torque	N·m	0.64	
Instantaneous maximum torque	N·m	1.91	
Rated current	A	1.7	
Instantaneous maximum current	A	5.2	
Rated speed	r/min	3,000	
Maximum speed	r/min	6,000	
Torque constant	N·m/A	0.41	
Voltage constant-KE	mV/(r/min)	14.3	
Rated power	Without brake	kW/s	28.2
	With brake		23.5
Mechanical time constant	Without brake	ms	0.72
	With brake		0.87
Electrical time constant	ms	2.53	
Rotor moment of inertia	Without brake	$\times 10^{-4} \text{kg} \cdot \text{m}^2$	0.14
	With brake		0.17

Brake Specifications

Item	Unit	Specifications
Usage	-	Holding
Rated voltage	V	DC 24V \pm 10 %
Rated current	A	0.3
Static friction torque	N·m	\geq 1.27
Pull-in time	ms	\leq 50
Release time	ms	\leq 15
Release voltage	V	\geq DC 1 V

Allowable load

Item	Unit	Specifications
Radial	N	245
Thrust	N	98

Torque Characteristics

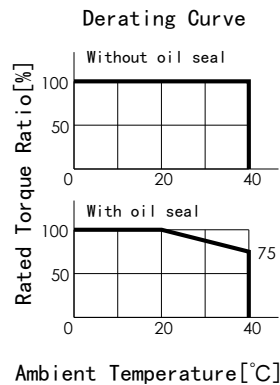
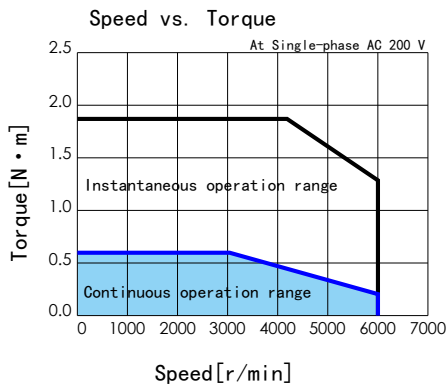

External Dimensions

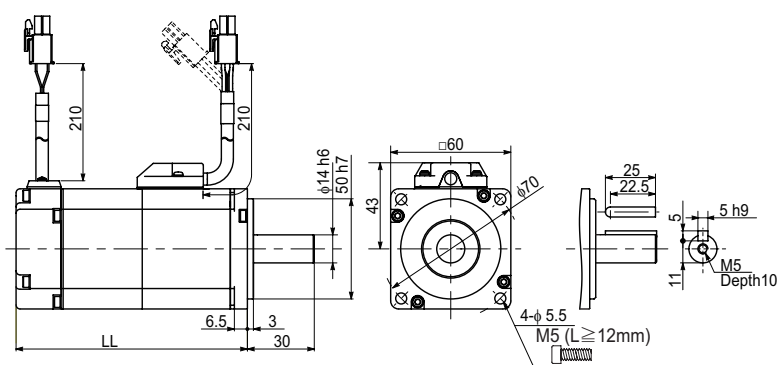

	(mm)	
Brake	Without	With
Motor Model	M3B020C*N	M3B020C*B
LL	76.5	113.0

The straight shaft products are not tapped end.

MOTOR SPECIFICATIONS

02 M7B020 200W High Inertia

Specifications

Motor Model : M7B020C □□□□* *



Basic Specifications

Item	Unit	Specifications	
Rotor inertia	-	High	
Fitting flange size	mm	60 sq.	
Approximate mass	Without brake	kg	1.0
	With brake		1.5
Compatible amplifier model	-	SD3020C1**	
Voltage	V	AC200 V to 240 V	
Rated output	W	200	
Rated torque	N·m	0.64	
Instantaneous maximum torque	N·m	1.91	
Rated current	A	1.7	
Instantaneous maximum current	A	5.2	
Rated speed	r/min	3,000	
Maximum speed	r/min	6,000	
Torque constant	N·m/A	0.41	
Voltage constant-KE	mV/(r/min)	14.3	
Rated power	Without brake	kW/s	9.1
	With brake		8.6
Mechanical time constant	Without brake	ms	2.23
	With brake		2.38
Electrical time constant	ms	2.53	
Rotor moment of inertia	Without brake	$\times 10^{-4} \text{kg} \cdot \text{m}^2$	0.44
	With brake		0.47

Brake Specifications

Item	Unit	Specifications
Usage	-	Holding
Rated voltage	V	DC 24 V \pm 10 %
Rated current	A	0.3
Static friction torque	N·m	≥ 1.27
Pull-in time	ms	≤ 50
Release time	ms	≤ 15
Release voltage	V	$\geq \text{DC } 1 \text{ V}$

Allowable load

Item	Unit	Specifications
Radial	N	245
Thrust	N	98

Torque Characteristics

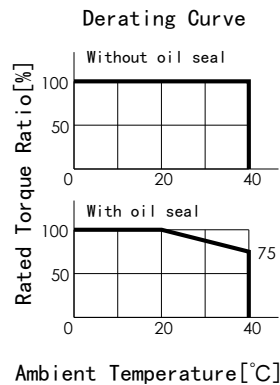
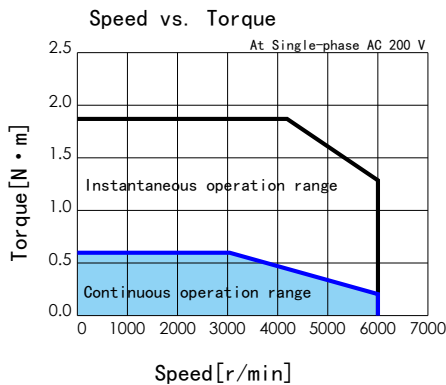

External Dimensions

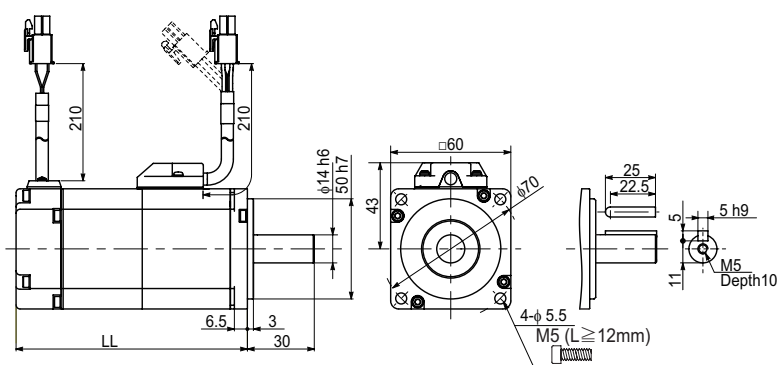

	(mm)	
Brake	Without	With
Motor Model	M7B020C*N	M7B020C*B
LL	93.5	130.0

The straight shaft products are not tapped end.

MOTOR SPECIFICATIONS

02 M3B040 400W Low Inertia

Specifications

Motor Model : M3B040C □□□□* *



Basic Specifications

Item	Unit	Specifications
Rotor inertia	-	Low
Fitting flange size	mm	60 sq.
Approximate mass	Without brake	kg
	With brake	1.3
Compatible amplifier model	-	SD3040C2**
Voltage	V	AC200 V to 240 V
Rated output	W	400
Rated torque	N·m	1.27
Instantaneous maximum torque	N·m	3.82
Rated current	A	2.7
Instantaneous maximum current	A	8.5
Rated speed	r/min	3,000
Maximum speed	r/min	6,000
Torque constant	N·m/A	0.49
Voltage constant-KE	mV/(r/min)	17.1
Rated power	Without brake	kW/s
	With brake	69.4
Mechanical time constant	Without brake	ms
	With brake	0.47
Electrical time constant	ms	0.53
Rotor moment of inertia	Without brake	$\times 10^{-4} \text{kg} \cdot \text{m}^2$
	With brake	2.92
		0.23
		0.26

Brake Specifications

Item	Unit	Specifications
Usage	-	Holding
Rated voltage	V	DC 24 V \pm 10 %
Rated current	A	0.3
Static friction torque	N·m	≥ 1.27
Pull-in time	ms	≤ 50
Release time	ms	≤ 15
Release voltage	V	$\geq \text{DC } 1 \text{ V}$

Allowable load

Item	Unit	Specifications
Radial	N	245
Thrust	N	98

Torque Characteristics

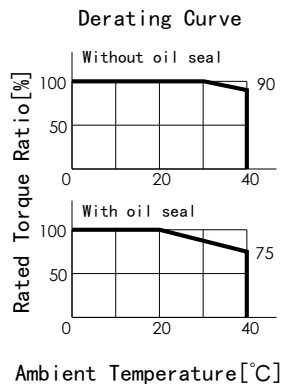
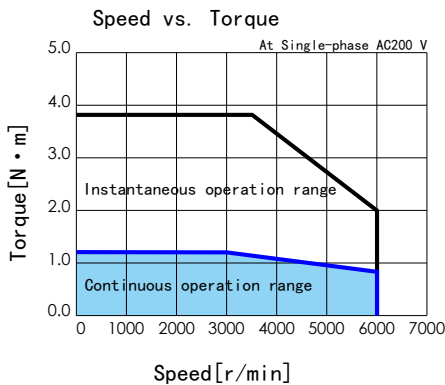

External Dimensions

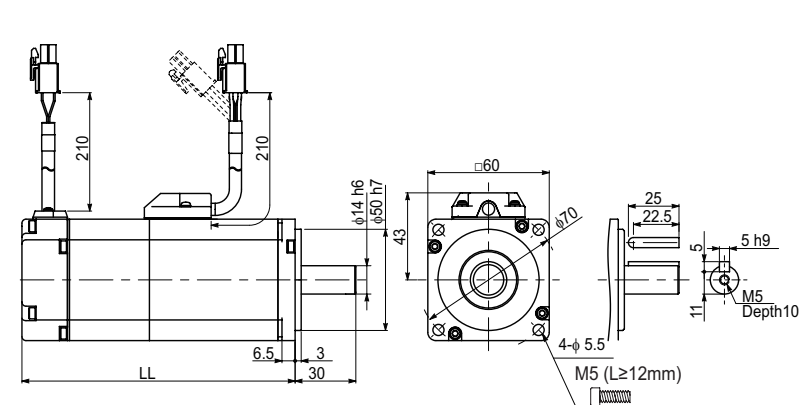

	(mm)	
Brake	Without	With
Motor Model	M3B040C*N	M3B040C*B
LL	93.5	130.0

The straight shaft products are not tapped end.

MOTOR SPECIFICATIONS

02 M7B040 400W High Inertia

Specifications

Motor Model : M7B040C □□□□* *

400W

60

17

60/30

IP65

Basic Specifications

Item	Unit	Specifications	
Rotor inertia	-	High	
Fitting flange size	mm	60 sq.	
Approximate mass	Without brake	kg	1.5
	With brake	kg	2.0
Compatible amplifier model	-	SD3040C2**	
Voltage	V	AC200 V to 240 V	
Rated output	W	400	
Rated torque	N·m	1.27	
Instantaneous maximum torque	N·m	3.82	
Rated current	A	2.7	
Instantaneous maximum current	A	8.5	
Rated speed	r/min	3,000	
Maximum speed	r/min	6,000	
Torque constant	N·m/A	0.49	
Voltage constant-KE	mV/(r/min)	17.1	
Rated power	Without brake	kW/s	23.0
	With brake		22.1
Mechanical time constant	Without brake	ms	1.42
	With brake		1.47
Electrical time constant	ms	2.92	
Rotor moment of inertia	Without brake	$\times 10^{-4} \text{kg} \cdot \text{m}^2$	0.71
	With brake		0.73

Brake Specifications

Item	Unit	Specifications
Usage	-	Holding
Rated voltage	V	DC 24 V \pm 10 %
Rated current	A	0.3
Static friction torque	N·m	≥ 1.27
Pull-in time	ms	≤ 50
Release time	ms	≤ 15
Release voltage	V	$\geq \text{DC } 1 \text{ V}$

Allowable load

Item	Unit	Specifications
Radial	N	245
Thrust	N	98

Torque Characteristics

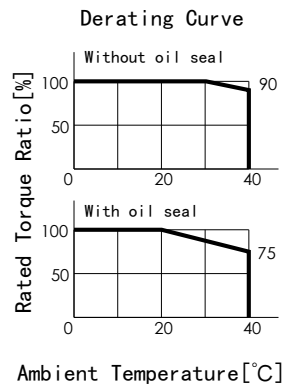
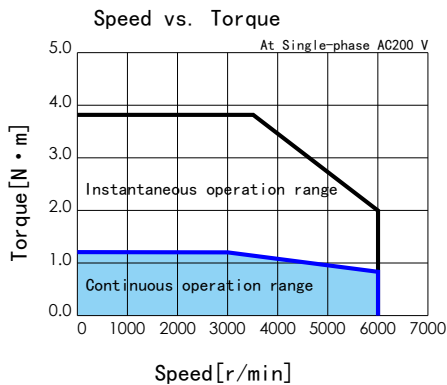

External Dimensions

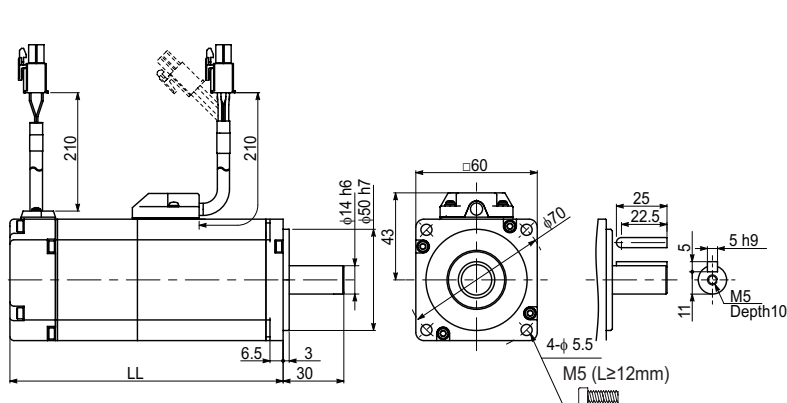

	(mm)	
Brake	Without	With
Motor Model	M7B040C*N	M7B040C*B
LL	110.5	147.0

The straight shaft products are not tapped end.

MOTOR SPECIFICATIONS

02 M3B075 750W Low Inertia

Specifications

Motor Model : M3B075C □□□□* *

750W

80mm

H3

60/30

IP65

Basic Specifications

Item	Unit	Specifications	
Rotor inertia	-	Low	
Fitting flange size	mm	80 sq.	
Approximate mass	Without brake	kg	2.2
	With brake		3.0
Compatible amplifier model	-	SD3080C3**	
Voltage	V	AC200 V to 240 V	
Rated output	W	750	
Rated torque	N·m	2.39	
Instantaneous maximum torque	N·m	7.1	
Rated current	A	4.2	
Instantaneous maximum current	A	12.2	
Rated speed	r/min	3,000	
Maximum speed	r/min	6,000	
Torque constant	N·m/A	0.63	
Voltage constant-KE	mV/(r/min)	21.9	
Rated power	Without brake	kW/s	76.6
	With brake		60.7
Mechanical time constant	Without brake	ms	0.40
	With brake		0.50
Electrical time constant	ms	4.60	
Rotor moment of inertia	Without brake	$\times 10^{-4} \text{kg} \cdot \text{m}^2$	0.74
	With brake		0.94

Brake Specifications

Item	Unit	Specifications
Usage	-	Holding
Rated voltage	V	DC 24 V \pm 10 %
Rated current	A	0.4
Static friction torque	N·m	≥ 2.39
Pull-in time	ms	≤ 70
Release time	ms	≤ 20
Release voltage	V	$\geq \text{DC } 1 \text{ V}$

Allowable load

Item	Unit	Specifications
Radial	N	392
Thrust	N	147

Torque Characteristics

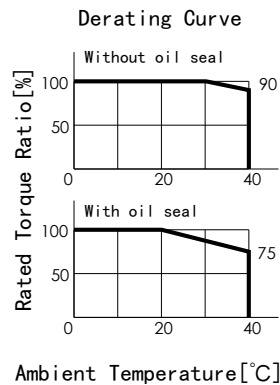
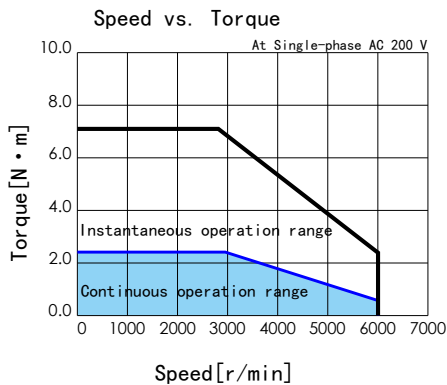

External Dimensions

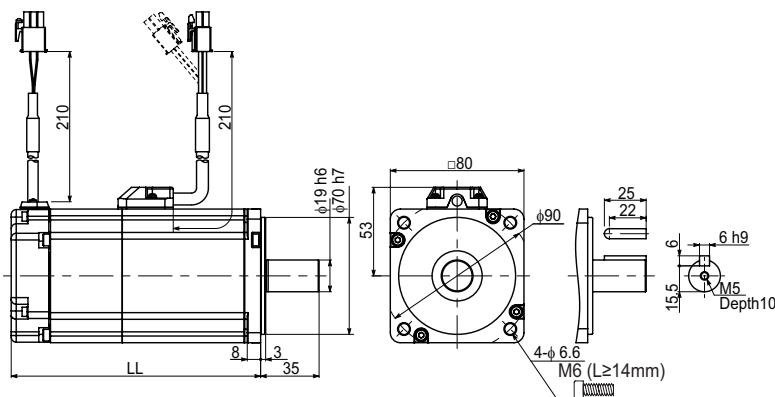

	(mm)	
	Without	With
Motor Model	M3B075C*N	M3B075C*B
LL	107.3	144.3

The straight shaft products are not tapped end.

Specifications

Motor Model : M7B075C □□□□* *



Basic Specifications

Item	Unit	Specifications	
Rotor inertia	-	High	
Fitting flange size	mm	80 sq.	
Approximate mass	Without brake	kg	2.5
	With brake	kg	3.3
Compatible amplifier model	-	SD3080C3**	
Voltage	V	AC200 V to 240 V	
Rated output	W	750	
Rated torque	N·m	2.39	
Instantaneous maximum torque	N·m	7.1	
Rated current	A	4.2	
Instantaneous maximum current	A	12.2	
Rated speed	r/min	3,000	
Maximum speed	r/min	6,000	
Torque constant	N·m/A	0.63	
Voltage constant-KE	mV/(r/min)	21.9	
Rated power	Without brake	kW/s	35.4
	With brake		31.6
Mechanical time constant	Without brake	ms	0.86
	With brake		0.96
Electrical time constant	ms	4.60	
Rotor moment of inertia	Without brake	$\times 10^{-4} \text{kg} \cdot \text{m}^2$	1.61
	With brake		1.81

Brake Specifications

Item	Unit	Specifications
Usage	-	Holding
Rated voltage	V	DC 24 V \pm 10 %
Rated current	A	0.4
Static friction torque	N·m	≥ 2.39
Pull-in time	ms	≤ 70
Release time	ms	≤ 20
Release voltage	V	$\geq \text{DC } 1 \text{ V}$

Allowable load

Item	Unit	Specifications
Radial	N	392
Thrust	N	147

Torque Characteristics

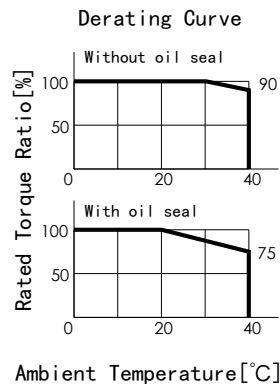
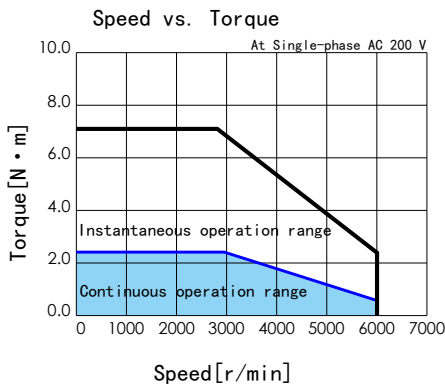

External Dimensions

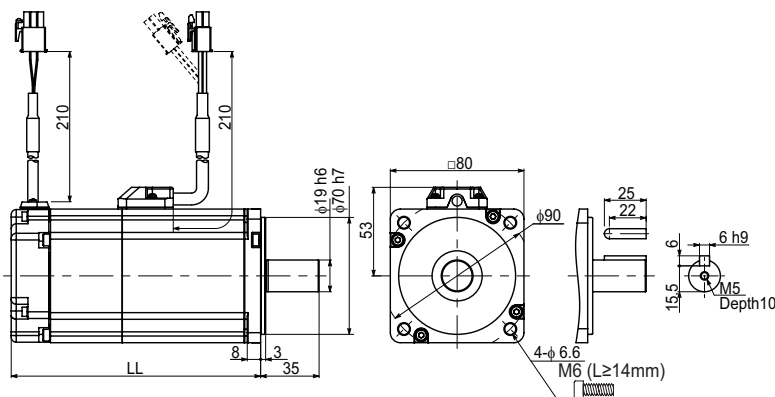

	(mm)	
Brake	Without	With
Motor Model	M7B075C*N	M7B075C*B
LL	122.3	159.3

The straight shaft products are not tapped end.

Specifications

Motor Model : M5A100C □□□□* *

1kW



Basic Specifications

Item	Unit	Specifications	
Rotor inertia	-	Middle	
Fitting flange size	mm	130 sq.	
Approximate mass	Without brake	kg	5.6
	With brake		7.0
Compatible amplifier model	-	SD3100C4**	
Voltage	V	AC200 V to 240 V	
Rated output	W	1,000	
Rated torque	N·m	4.77	
Instantaneous maximum torque	N·m	14.3	
Rated current	A	5.6	
Instantaneous maximum current	A	16.8	
Rated speed	r/min	2,000	
Maximum speed	r/min	3,000	
Torque constant	N·m/A	0.88	
Voltage constant-KE	mV/(r/min)	30.9	
Rated power	Without brake	kW/s	50.0
	With brake		36.5
Mechanical time constant	Without brake	ms	0.76
	With brake		1.05
Electrical time constant	ms	10.1	
Rotor moment of inertia	Without brake	$\times 10^{-4} \text{kg} \cdot \text{m}^2$	4.56
	With brake		6.24

Brake Specifications

Item	Unit	Specifications
Usage	-	Holding
Rated voltage	V	DC 24 V \pm 10 %
Rated current	A	1.0
Static friction torque	N·m	\geq 9.55
Pull-in time	ms	\leq 120
Release time	ms	\leq 30
Release voltage	V	\geq DC 1 V

Allowable load

Item	Unit	Specifications
Radial	N	490
Thrust	N	196

Torque Characteristics

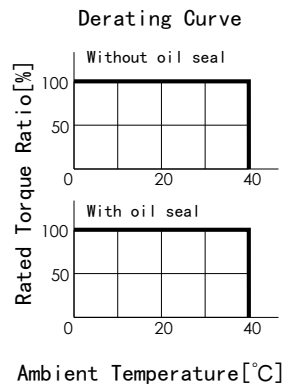
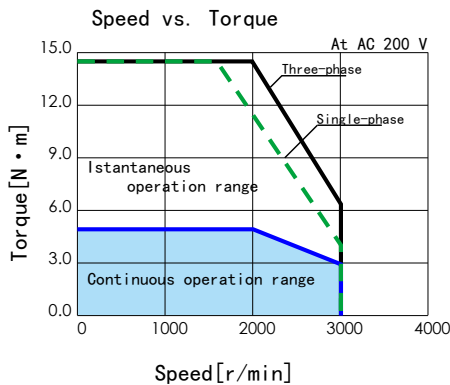

External Dimensions

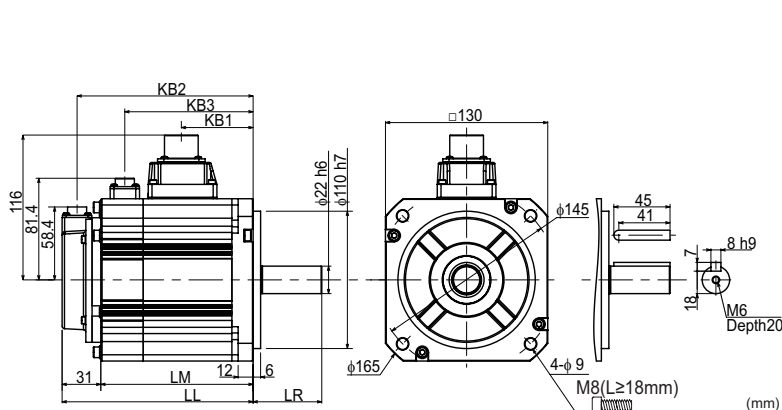

	(mm)	
Brake	Without	With
Motor Model	M5A100C*N	M5A100C*B
LL	128.0	153.0
LM	97.0	122.0
LR	55.0	
KB1	57.5	
KB2	116.0	141.0
KB3	-	102.8

The straight shaft products are not tapped end.

Specifications

Motor Model : M7A100C □□□□* *

1kW

130 SQUARE

IP7

50°C 20°C

IP67

Basic Specifications

Item	Unit	Specifications	
Rotor inertia	-	High	
Fitting flange size	mm	130 sq.	
Approximate mass	Without brake	kg	7.6
	With brake	kg	9.0
Compatible amplifier model	-	SD3100C4**	
Voltage	V	AC200 V to 240 V	
Rated output	W	1,000	
Rated torque	N·m	4.77	
Instantaneous maximum torque	N·m	14.3	
Rated current	A	5.6	
Instantaneous maximum current	A	16.8	
Rated speed	r/min	2,000	
Maximum speed	r/min	3,000	
Torque constant	N·m/A	0.88	
Voltage constant-KE	mV/(r/min)	30.9	
Rated power	Without brake	kW/s	9.2
	With brake		8.6
Mechanical time constant	Without brake	ms	4.17
	With brake		4.43
Electrical time constant	ms	10.1	
Rotor moment of inertia	Without brake	$\times 10^{-4} \text{kg} \cdot \text{m}^2$	24.9
	With brake		26.4

Brake Specifications

Item	Unit	Specifications
Usage	-	Holding
Rated voltage	V	DC 24 V \pm 10 %
Rated current	A	1.0
Static friction torque	N·m	\geq 9.55
Pull-in time	ms	\leq 120
Release time	ms	\leq 30
Release voltage	V	\geq DC 1 V

Allowable load

Item	Unit	Specifications
Radial	N	490
Thrust	N	196

Torque Characteristics

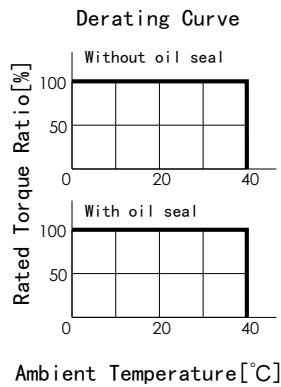
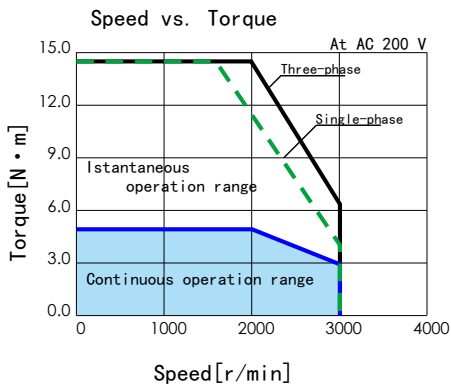

External Dimensions

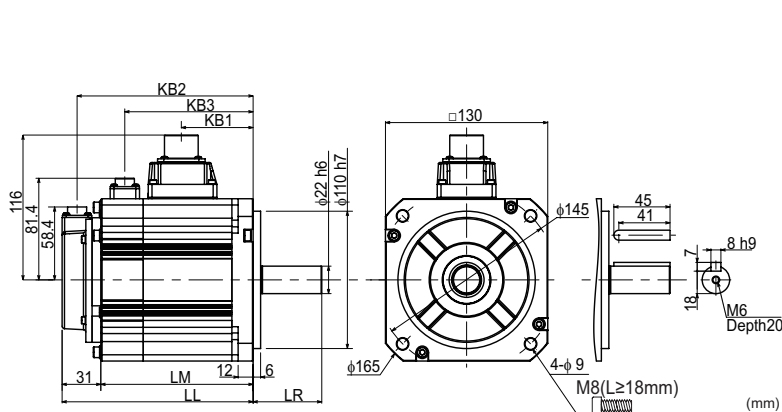

(mm)

Brake	Without	With
Motor Model	M7A100C*N	M7A100C*B
LL	163.0	188.0
LM	132.0	157.0
LR	70.0	
KB1	92.5	
KB2	151.0	176.0
KB3	-	137.8

The straight shaft products are not tapped end.

Specifications

Motor Model : M5A150C □□□□* *

1.5kW

130 SQUARE

F5

50°C 20°C

IP67

Basic Specifications

Item	Unit	Specifications	
Rotor inertia	-	Middle	
Fitting flange size	mm	130 sq.	
Approximate mass	Without brake	kg	7.0
	With brake		8.4
Compatible amplifier model	-	SD3150C6**	
Voltage	V	AC200 V to 240 V	
Rated output	W	1,500	
Rated torque	N·m	7.16	
Instantaneous maximum torque	N·m	21.5	
Rated current	A	9.0	
Instantaneous maximum current	A	27	
Rated speed	r/min	2,000	
Maximum speed	r/min	3,000	
Torque constant	N·m/A	0.81	
Voltage constant-KE	mV/(r/min)	28.4	
Rated power	Without brake	kW/s	76.9
	With brake		61.4
Mechanical time constant	Without brake	ms	0.60
	With brake		0.75
Electrical time constant	ms	12.2	
Rotor moment of inertia	Without brake	$\times 10^{-4} \text{kg} \cdot \text{m}^2$	6.67
	With brake		8.35

Brake Specifications

Item	Unit	Specifications
Usage	-	Holding
Rated voltage	V	DC 24 V \pm 10 %
Rated current	A	1.0
Static friction torque	N·m	≥ 9.55
Pull-in time	ms	≤ 120
Release time	ms	≤ 30
Release voltage	V	$\geq \text{DC } 1 \text{ V}$

Allowable load

Item	Unit	Specifications
Radial	N	490
Thrust	N	196

Torque Characteristics

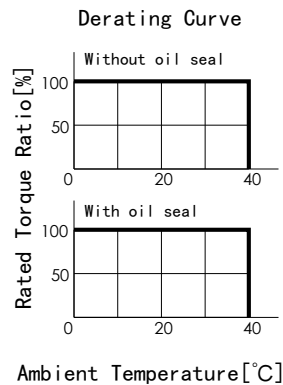
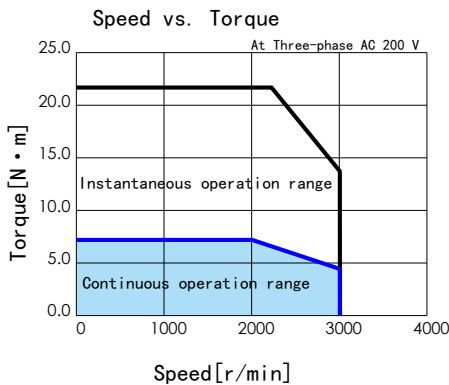

External Dimensions

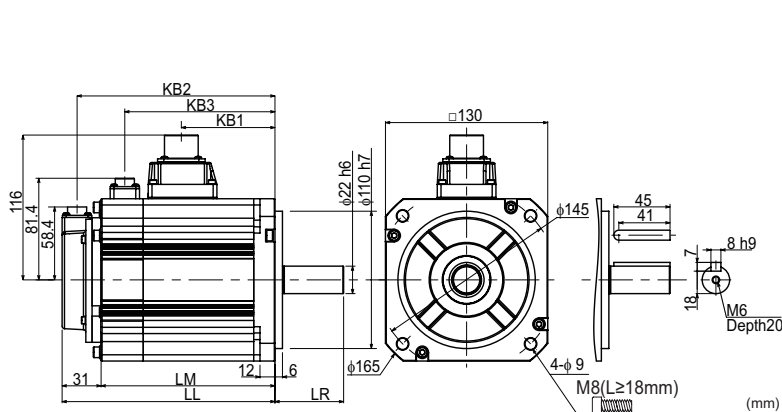

(mm)

Brake	Without	With
Motor Model	M5A150C*N	M5A150C*B
LL	145.5	170.5
LM	114.5	139.5
LR	55.0	
KB1	75.0	
KB2	133.5	158.5
KB3	-	120.3

The straight shaft products are not tapped end.

MOTOR SPECIFICATIONS

02 M7A150 1.5kW High Inertia

Specifications

Motor Model : M7A150C □□□□* *

1.5kW

130 SQUARE

7

50-20

IP67

Basic Specifications

Item	Unit	Specifications	
Rotor inertia	-	High	
Fitting flange size	mm	130 sq.	
Approximate mass	Without brake	kg	9.0
	With brake		10.4
Compatible amplifier model	-	SD3150C6**	
Voltage	V	AC200 V to 240 V	
Rated output	W	1,500	
Rated torque	N·m	7.16	
Instantaneous maximum torque	N·m	21.5	
Rated current	A	9.0	
Instantaneous maximum current	A	27	
Rated speed	r/min	2,000	
Maximum speed	r/min	3,000	
Torque constant	N·m/A	0.81	
Voltage constant-KE	mV/(r/min)	28.4	
Rated power	Without brake	kW/s	13.8
	With brake		13.3
Mechanical time constant	Without brake	ms	3.32
	With brake		3.46
Electrical time constant	ms	12.2	
Rotor moment of inertia	Without brake	$\times 10^{-4} \text{kg} \cdot \text{m}^2$	37.12
	With brake		38.65

Brake Specifications

Item	Unit	Specifications
Usage	-	Holding
Rated voltage	V	DC 24 V \pm 10 %
Rated current	A	1.0
Static friction torque	N·m	≥ 9.55
Pull-in time	ms	≤ 120
Release time	ms	≤ 30
Release voltage	V	\geq DC 1 V

Allowable load

Item	Unit	Specifications
Radial	N	490
Thrust	N	196

Torque Characteristics

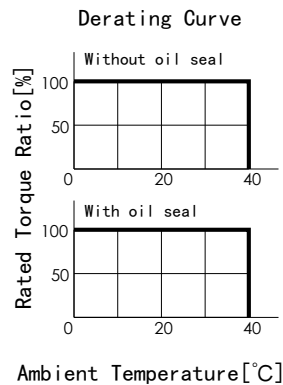
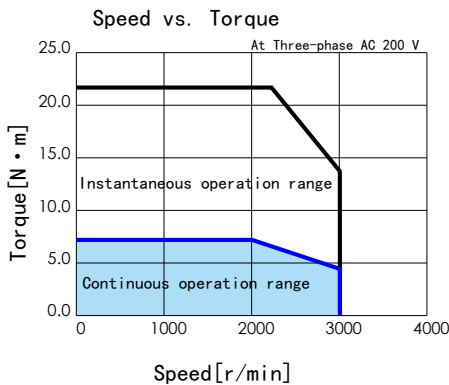

External Dimensions

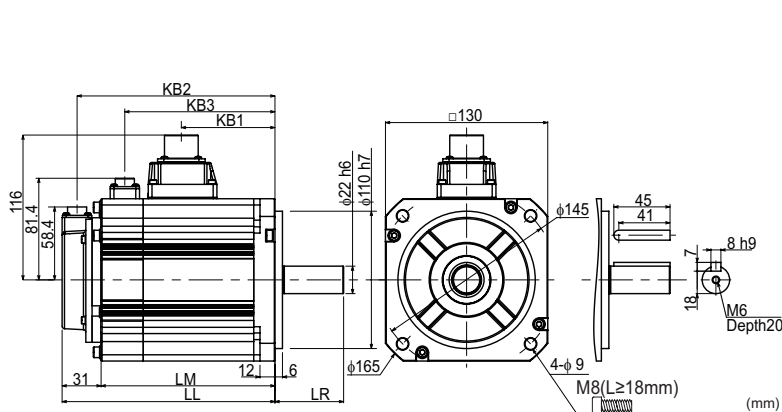

(mm)

Brake	Without	With
Motor Model	M7A150C*N	M7A150C*B
LL	180.5	205.5
LM	149.5	174.5
LR	70.0	
KB1	110.0	
KB2	168.5	19.35
KB3	-	155.3

The straight shaft products are not tapped end.

Specifications

Motor Model : M5A200C □□□□* *



Basic Specifications

Item	Unit	Specifications	
Rotor inertia	-	Middle	
Fitting flange size	mm	130 sq.	
Approximate mass	Without brake	kg	8.4
	With brake	kg	9.8
Compatible amplifier model	-	SD3200C8**	
Voltage	V	AC200 V to 240 V	
Rated output	W	2,000	
Rated torque	N·m	9.55	
Instantaneous maximum torque	N·m	28.6	
Rated current	A	11.9	
Instantaneous maximum current	A	35.7	
Rated speed	r/min	2,000	
Maximum speed	r/min	3,000	
Torque constant	N·m/A	0.85	
Voltage constant-KE	mV/(r/min)	29.6	
Rated power	Without brake	kW/s	104.9
	With brake		87.9
Mechanical time constant	Without brake	ms	0.58
	With brake		0.69
Electrical time constant	ms	12.2	
Rotor moment of inertia	Without brake	$\times 10^{-4} \text{kg} \cdot \text{m}^2$	8.70
	With brake		10.38

Brake Specifications

Item	Unit	Specifications
Usage	-	Holding
Rated voltage	V	DC 24 V \pm 10 %
Rated current	A	1.0
Static friction torque	N·m	\geq 9.55
Pull-in time	ms	\leq 120
Release time	ms	\leq 30
Release voltage	V	\geq DC 1 V

Allowable load

Item	Unit	Specifications
Radial	N	490
Thrust	N	196

Torque Characteristics

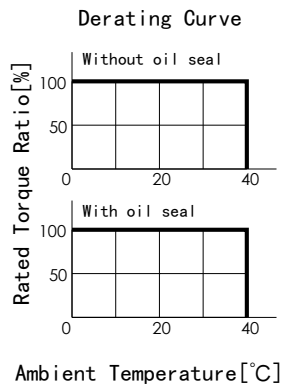
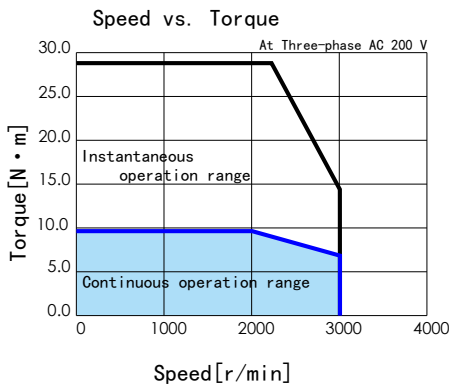

External Dimensions

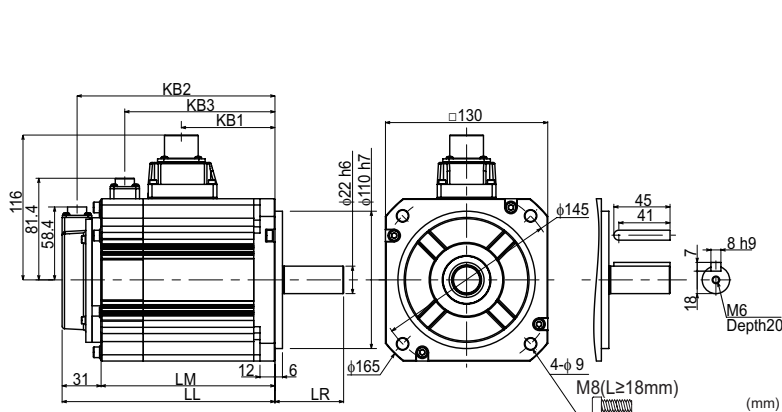

(mm)

Brake	Without	With
Motor Model	M5A200C*N	M5A200C*B
LL	163.0	188.0
LM	132.0	157.0
LR	55.0	
KB1	92.5	
KB2	151.0	176.0
KB3	-	137.8

The straight shaft products are not tapped end.

03 MOTOR ENCODER SPECIFICATIONS

Motor Basic Specifications

Item	Specifications
Ambient temperature for operation	0 to 40 °C
Ambient humidity for operation	20 to 85 %RH (non-condensing)
Ambient temperature for storage	- 20 to 65 °C (non-condensing) (not subjected to direct sunlight) 80 °C for 72 hours
Ambient humidity for storage	20 to 85 %RH (non-condensing)
Atmosphere for operation / storage	Indoors (not subject to direct sunlight) , Free from corrosive gases, flammable gases, oil mist, dust, flammables, grinding fluid
Insulation resistance	≥ 5 MΩ at 1,000 VDC
Insulation strength	AC 1500 V for one minute across the primary and FG
Altitude	≤ 1,000 m
Vibration class	V15 (JEC2121)
Vibration resistance	49 m/s ² (5 G)
Impact resistance	98 m/s ² (10 G)
IP Rating	IP65 : 50 W to 750 W, IP67 : 1 kW to 2 kW
Electric shock protection	Class I (Mandatory grounding)
Overvoltage category	II
Installation environment	Pollution degree 2

Encoder Specifications

Item		Specifications		
Motor model		M□□□□□C□□□C* *	M□□□□□C□□□□A* *	
Resolution		Incremental 17 bit	Absolute 17 bit	
Environmental requirements	Ambient operating temperature	0 to 85 °C		
	External disturbance magnetic field	±2 mT (20 G) or below		
Electrical specifications	Power supply	Voltage	DC 4.5 to 5.5 V (Power supply ripple ≤ 5 %)	
		Current consumption	160 mA typ. (Not including rush current)	
	External battery	Voltage	-	DC 2.4 to 4.2V
		Current consumption	-	10 μA typ. ^(*1)
	Multi-turn count	-	65,536 counts	
	Maximum revolving speed	6,000 r/min		
Count-up direction	CCW ^(*2)			
Input/output type	Differential transform			
Communication specification	Transmission method	Half-duplex asynchronous serial communication		
	Communication speed	2.5 Mbps		

*1) Measurement conditions
room temperature, the motor not in motion, battery voltage of 3.6 V.

*2) CCW when viewed from the load side shaft end.

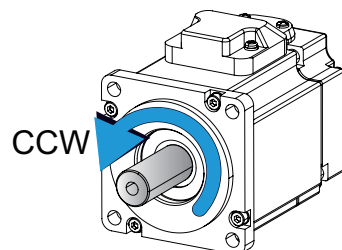

Precautions

Using the motor with rotations of 180 degrees or less will reduce the encoder's rotational accuracy.

For a motor equipped with a brake, follow the brake voltage and polarity specifications.

If the brake voltage is less than 12 V or the polarity is reversed, the encoder's rotational accuracy will be reduced.

04 AMPLIFIER MODELS

Amplifiers

Rated output

- 50W
- 100W
- 200W
- 400W

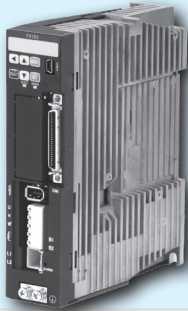

Rated output

- 750W



Rated output

- 1kW



Rated output

- 1.5kW
- 2kW



Model Number

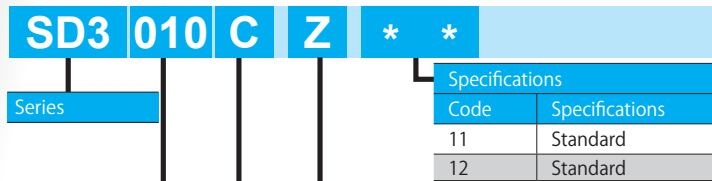

Compatible Motor

Code	Model	Rated Output
Y	M□□005C□□□□ **	50 W
Z	M□□010C□□□□ **	100 W
1	M□□020C□□□□ **	200 W
2	M□□040C□□□□ **	400 W
3	M□□075C□□□□ **	750 W
4	M□□100C□□□□ **	1000 W
6	M□□150C□□□□ **	1500W
8	M□□200C□□□□ **	2000W

Input Power Supply

Code	Main Circuit Power	Control Power
C	AC200 V to 240 V (*)	DC24 V

(*) Single- or Three-phase option depends on compatible motor.

- 50 W to 750 W : Single-phase
- 1 kW : Single-phase / Three-phase
- 1.5 kW, 2 kW : Three-phase

Main Circuit Power Supply

Code	Supply
005	50 W
010	100 W
020	200 W
040	400 W
080	750 W
100	1000W
150	1500W
200	2000W

Amplifier / Motor Combinations

Rated Output	Amplifier Model	Motor Model
50 W	SD3005CY**	M□□005C□□□□ **
100 W	SD3010CZ**	M□□010C□□□□ **
200 W	SD3020C1**	M□□020C□□□□ **
400 W	SD3040C2**	M□□040C□□□□ **
750 W	SD3075C3**	M□□075C□□□□ **
1000W	SD3100C4**	M□□100C□□□□ **
1500W	SD3150C6**	M□□150C□□□□ **
2000W	SD3200C8**	M□□200C□□□□ **



05 AMPLIFIER SPECIFICATIONS

Basic Specifications

Item		Specifications								
Model		SD3005CY**	SD3010CZ**	SD3020C1**	SD3040C2**	SD3080C3**	SD3100C4**	SD3150C6**	SD3200C8**	
Compatible Motor		M□□005	M□□010	M□□020	M□□040	M□□075	M□□100	M□□150	M□□200	
External dimensions		(See "Dimensions" beginning on page 28.)								
Weight (Kg)		0.7			0.8		1.0		1.6	
Input power	Main circuit power	Single-phase AC200 V to 240 V ± 10 % 50 / 60 Hz					Three-phase AC200 V to 240 V ± 10 % 50 / 60 Hz			
	Control power	DC24V ± 10 %								
	Input current (Arms typ)	0.8	1.3	2.4	3.6	7.2	Single-phase : 9.7 Three-phase : 5.1	6.1	9.0	
	Control power Current Consumption (mA Typ.)	170			210	260	240	350		
Control of main circuit		Three-phase PWM inverter sine-wave driven								
Output Rating	Rated current (A)	0.7	1.0	1.7	2.7	4.3	5.8	5.6	9.9	12.2
	Output frequencies (Hz)	0 to 500					0 to 250			
Encoder feedback		17 bit single-turn absolute (The product can function as a multi-turn absolute type when batteries are added.)								
Control signal	Input	8-point (24 VDC system, photo-coupler input insulation) inputs whose functions are switched by the control mode								
	Output	8-point (24 VDC system, open-collector output insulation) outputs whose functions are switched by the control mode								
Analog signal	Input	1-point (± 10 V) input whose functions can be switched by the control mode								
Pulse signal	Input	RS-422 differential Open-collector								
	Output	Encoder feedback pulse (A-/B-/Z-phase), RS-422 differential output Z-phase pulse through open-collector as well								
Communication function		USB : connection to PC with "Servo Studio" installed RS-485 : host remote control communication (multi-drop compatible)								
Amplifier status display function		Amplifier status display function 6 digits of seven-segment display on Setup Panel Normal/Error display on STATUS LED Green light when Power ON Normal, Red light when Power ON Error, Dim when Power OFF								
Regeneration function		A regenerative resistor may be installed externally								
Dynamic brake		None Optional dynamic brake unit "SP03101" or "SP03102" is available for 50 W to 1 kW. Building your own dynamic brake unit for 1.5 kW to 2 kW. (See "Dynamic Brake Circuit" on page 34)								
Control mode		Position Control, Velocity Control, Torque Control								

Environmental Specification

Item		Specifications
Ambient temperature	For operation	0 to 55 °C
	For storage	- 20 to 65 °C
Ambient humidity	For operation	20 to 85 % RH (non-condensing)
	For storage	
Atmosphere for operation and storage		Indoors (not subject to direct sunlight) , Free from corrosive gases, flammable gases, oil mist, dust, flammables, grinding fluid
Altitude		≤ 1,000 m
Vibration		≤ 5.8 m/s ² (0.6 G) 10 to 60 Hz (no continuous operation allowed at frequency of resonance)
Dielectric strength		AC 1,500 V for one minute across the primary and FG
Electric shock protection		Class I (mandatory grounding)
Overvoltage category		II
Installation environment		Pollution degree 2

05 AMPLIFIER SPECIFICATIONS

Functions Specifications

Item		Specifications	
Position Control Mode	Pulse Input	Control input	Servo ON, alarm reset, command input not allowed, emergency stop, deviation counter clear, 2-stage torque limit, CCW/CW run not allowed, ABS data demand, homing start
		Control output	under torque limit Alarm status, servo status, servo ready, under torque limit, brake release, positioning complete, motion complete, alarm, dynamic brake release, ABS data transmitting, homing complete
		Maximum command pulse frequency	RS-422 differential : 4 Mpps Open-collector : 200 kpps
		Input pulse signal form	Pulse + Direction, A-/B-phase quadrature encoder pulse, CW + CCW pulse
		Electronic gear	ratio A/B $1/1,000 < A/B < 1,000$ Setting range A : 1 to 65,535 B : 1 to 65,535
	Internal Position	Control input	Servo ON, alarm reset, deviation counter clear, motion start point selection 16, home position sensor input, homing start
		Control output	Alarm status, servo status, servo ready, under torque limit, brake release, homing complete, motion complete
		Operation mode	Point table, communication operation
	Smoothing filter		FIR Filter
	Damping control		Enabled
Velocity Control Mode	Analog Velocity	Control input	Servo ON, alarm reset, command input inhibit (zero torque command), 2-stage torque limit, CCW/CW run prohibited
		Control output	Alarm status, servo status, servo ready, under torque limit, brake release
		Speed command input	Input voltage $-10\text{ V to }+10\text{ V}$ (max speed is reached at $\pm 10\text{ V}$)
	Internal Velocity	Control input	Servo ON, alarm reset, start 1 (CCW), start 2 (CW), 8-stage speed command 2-stage torque limit
		Control output	Alarm status, servo status, servo ready, under torque limit, brake release
	Smoothing filter		IIR Filter, FIR Filter
Torque Control Mode	Analog Torque	Control input	Servo ON, alarm reset, command input not allowed (zero clamp command) 2-stage torque limit, CCW/CW run prohibited
		Control output	Alarm status, servo status, servo ready, under torque limit, brake release
		Torque command input	Input voltage, $-10\text{ V to }+10\text{ V}$ (max speed is reached at $\pm 10\text{ V}$)
	Smoothing filter		IIR Filter
Common Features	Speed observer		Available
	Auto-tuning		Available
	Encoder output Division/Multiplication		Available
	Tuning & Function Setup		Available through the SD3 setup software "Servo Studio" Tuning with the setup panel on the amplifier front side
	Protective functions	By hardware	Overvoltage, low voltage, Overcurrent, Abnormal temperature, Overload, Encoder error
		By software	Overspeed, Position deviation too high, Parameter errors
Alarm Log		Can be referenced with the setup software Servo Studio	

AMPLIFIER SPECIFICATIONS

06 DIMENSIONS

Figure 1

- 50W
- 100W
- 200W
- 400W
- 750W
- 1kW
- 1.5kW
- 2kW

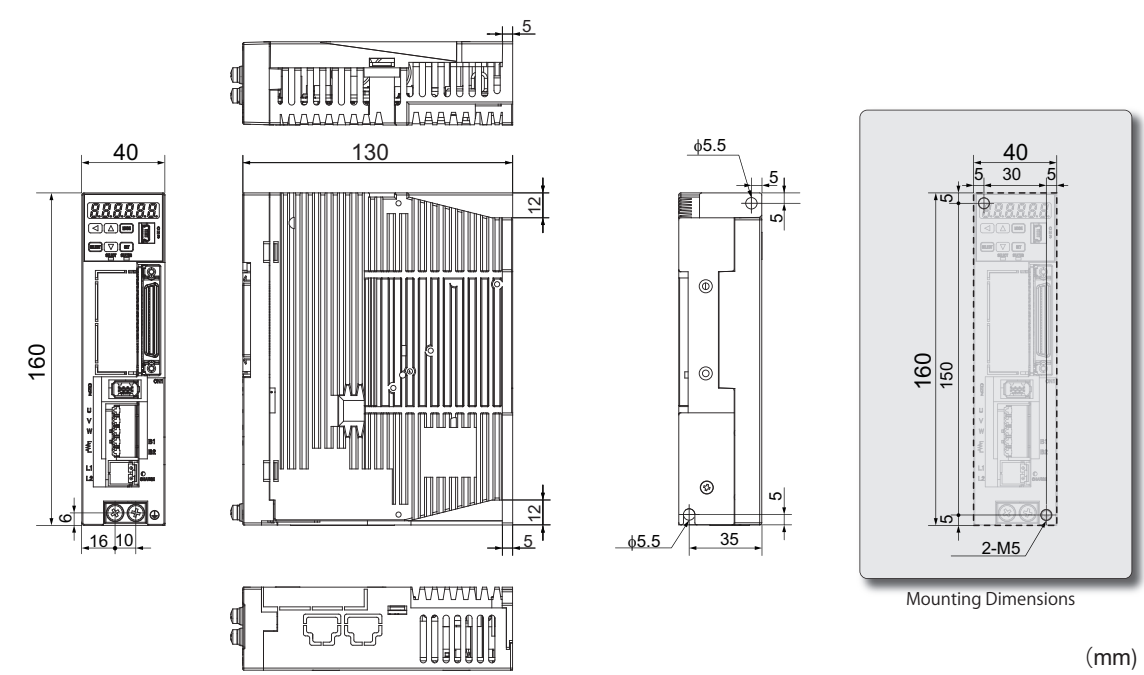

Figure 2

- 50W
- 100W
- 200W
- 400W
- 750W
- 1kW
- 1.5kW
- 2kW

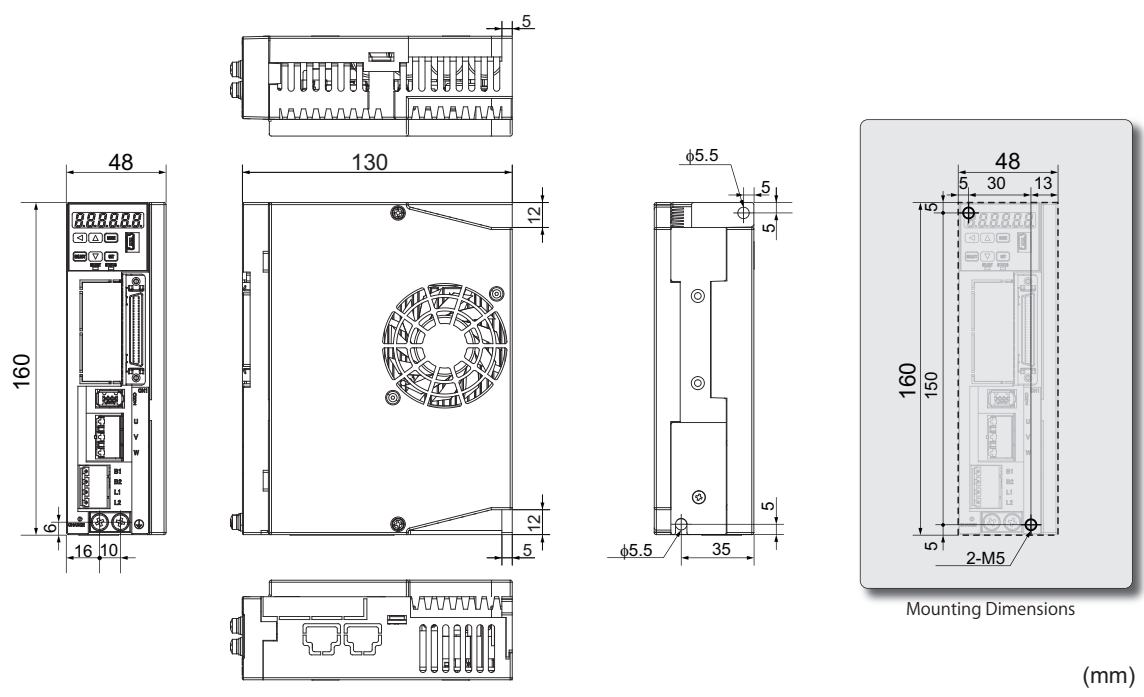

Figure 3

- 50W
- 100W
- 200W
- 400W
- 750W
- 1kW
- 1.5kW
- 2kW

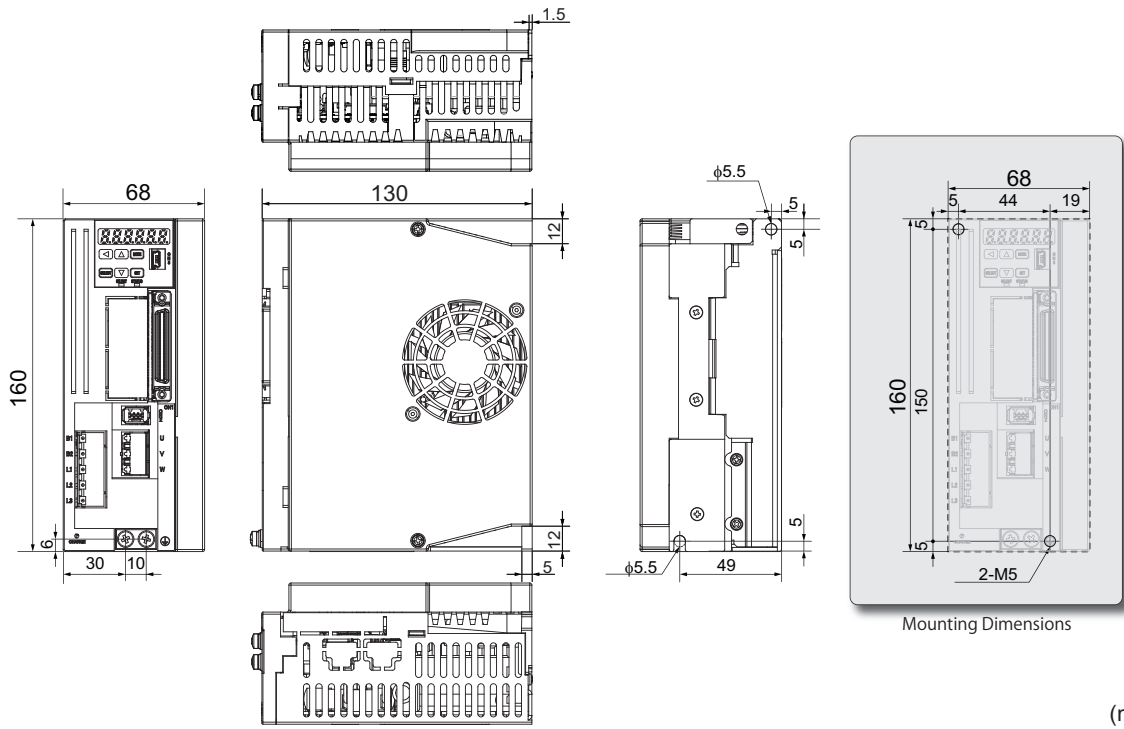
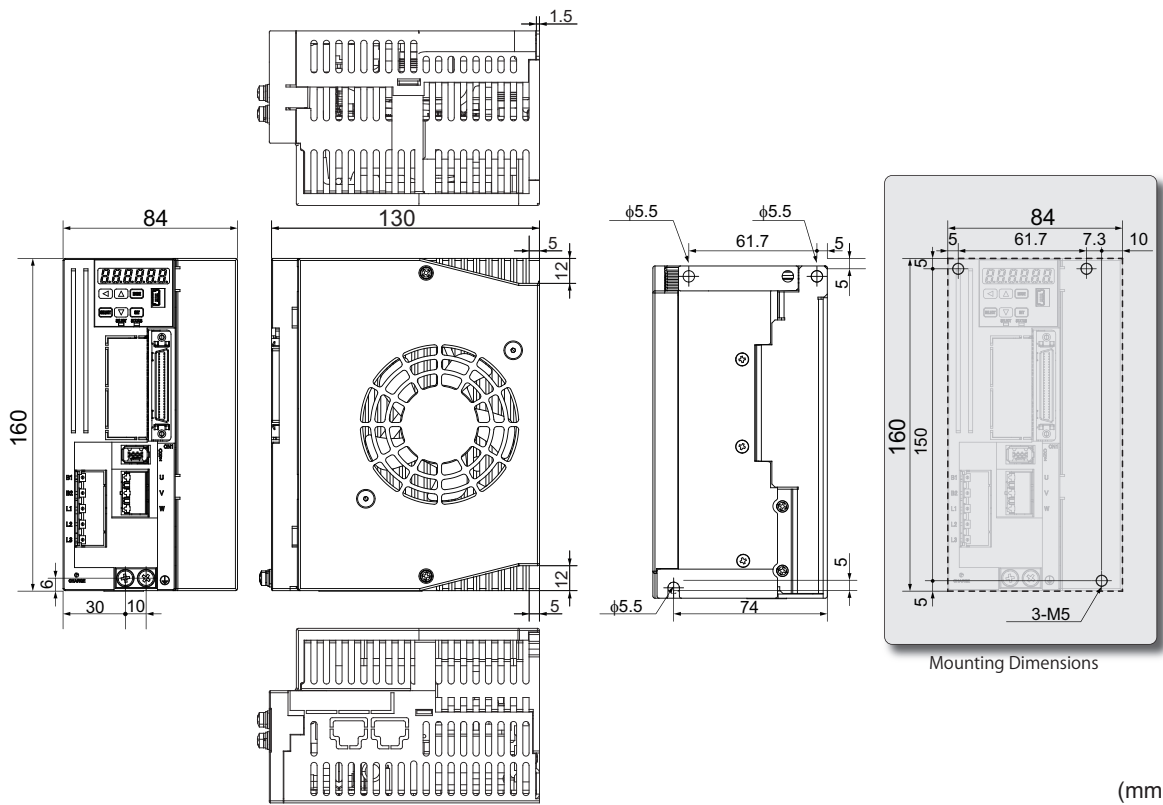

Figure 4

- 50W
- 100W
- 200W
- 400W
- 750W
- 1kW
- 1.5kW
- 2kW



07 SYSTEM WIRING

Wiring Pattern 1

50W

100W

200W

400W

750W

1kW

1.5kW

2kW

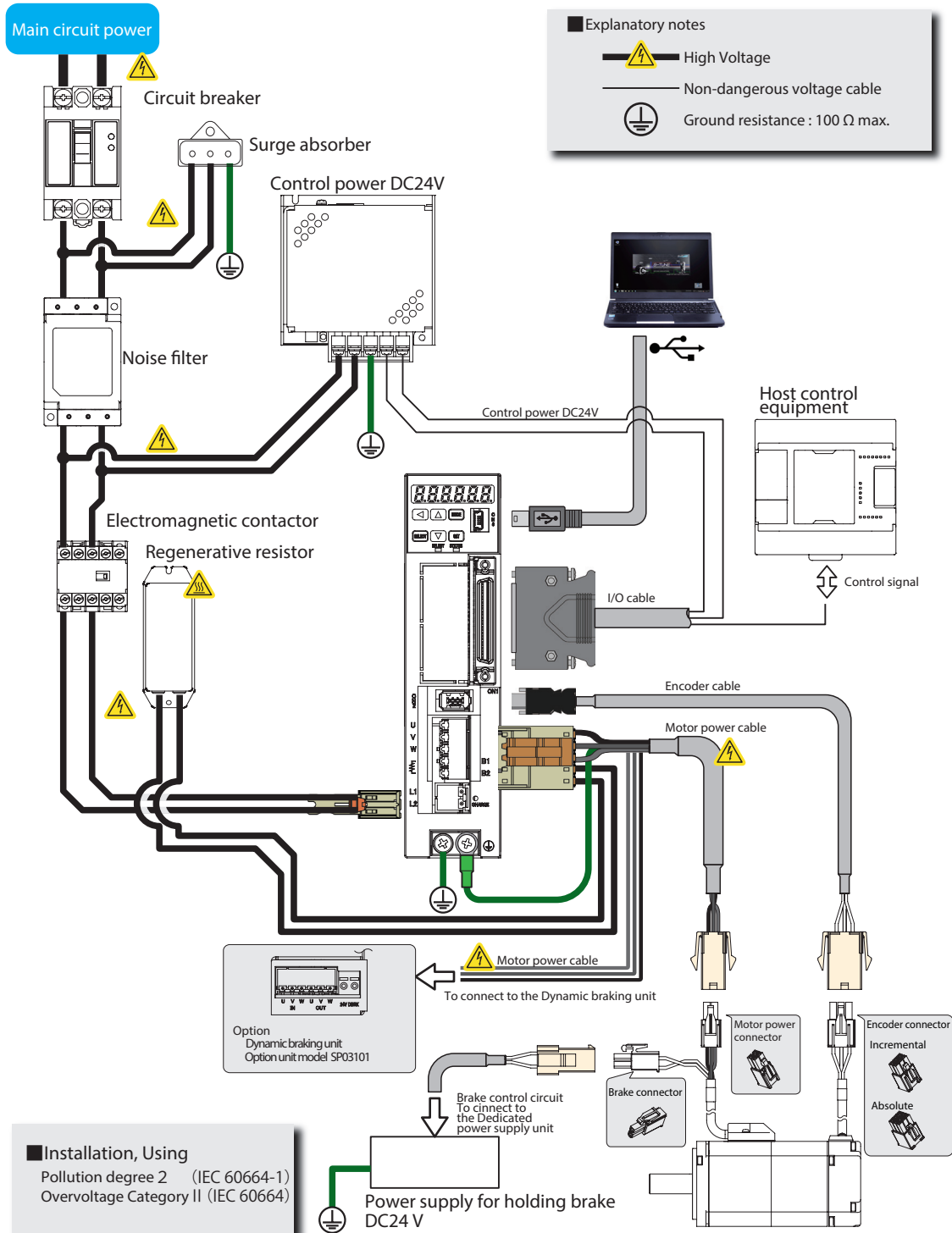

07 SYSTEM WIRING

Wiring Pattern 2

50W

100W

200W

400W

750W

1kW

1.5kW

2kW

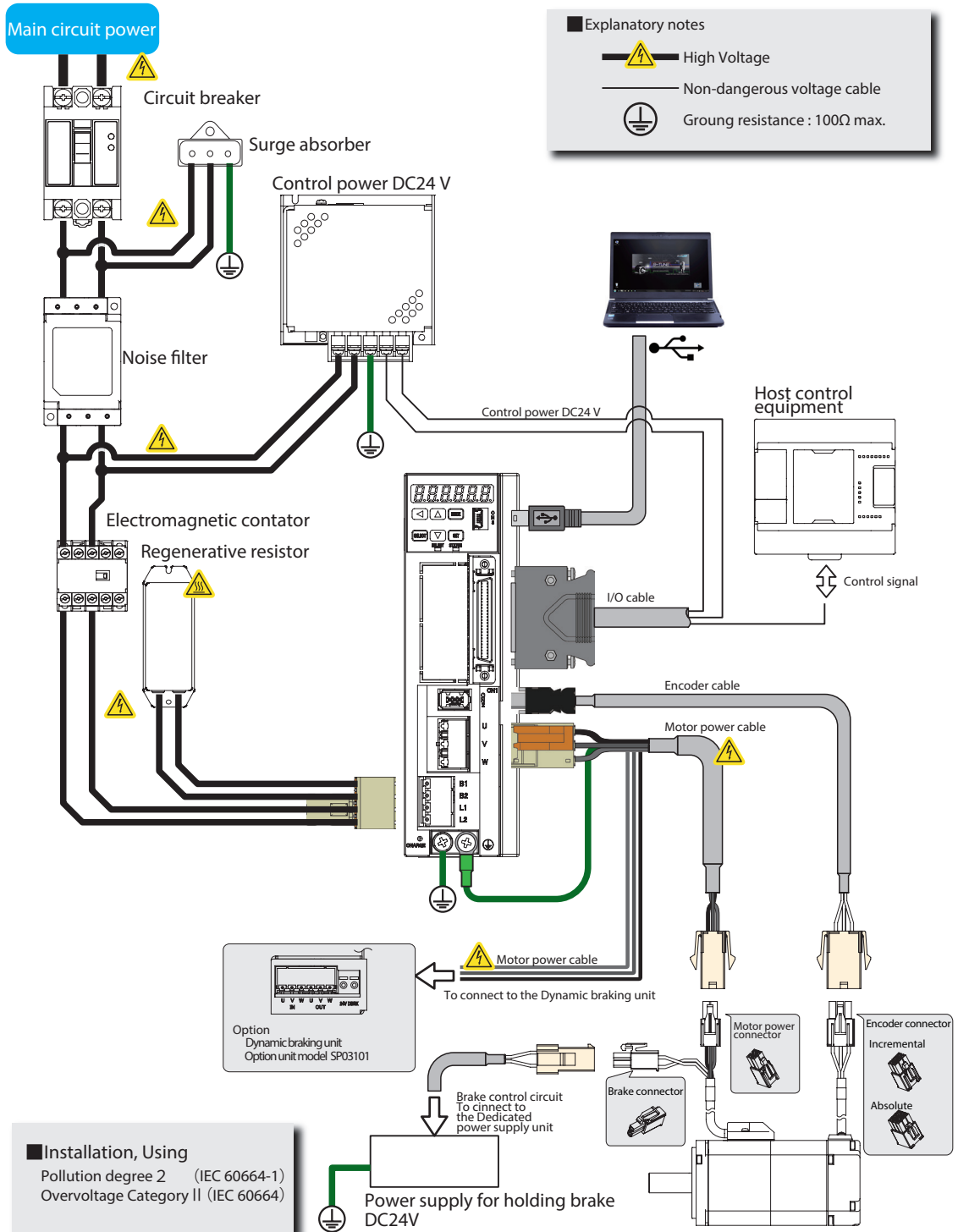

07 SYSTEM WIRING

Wiring Pattern 3

50W

100W

200W

400W

750W

1kW

1.5kW

2kW

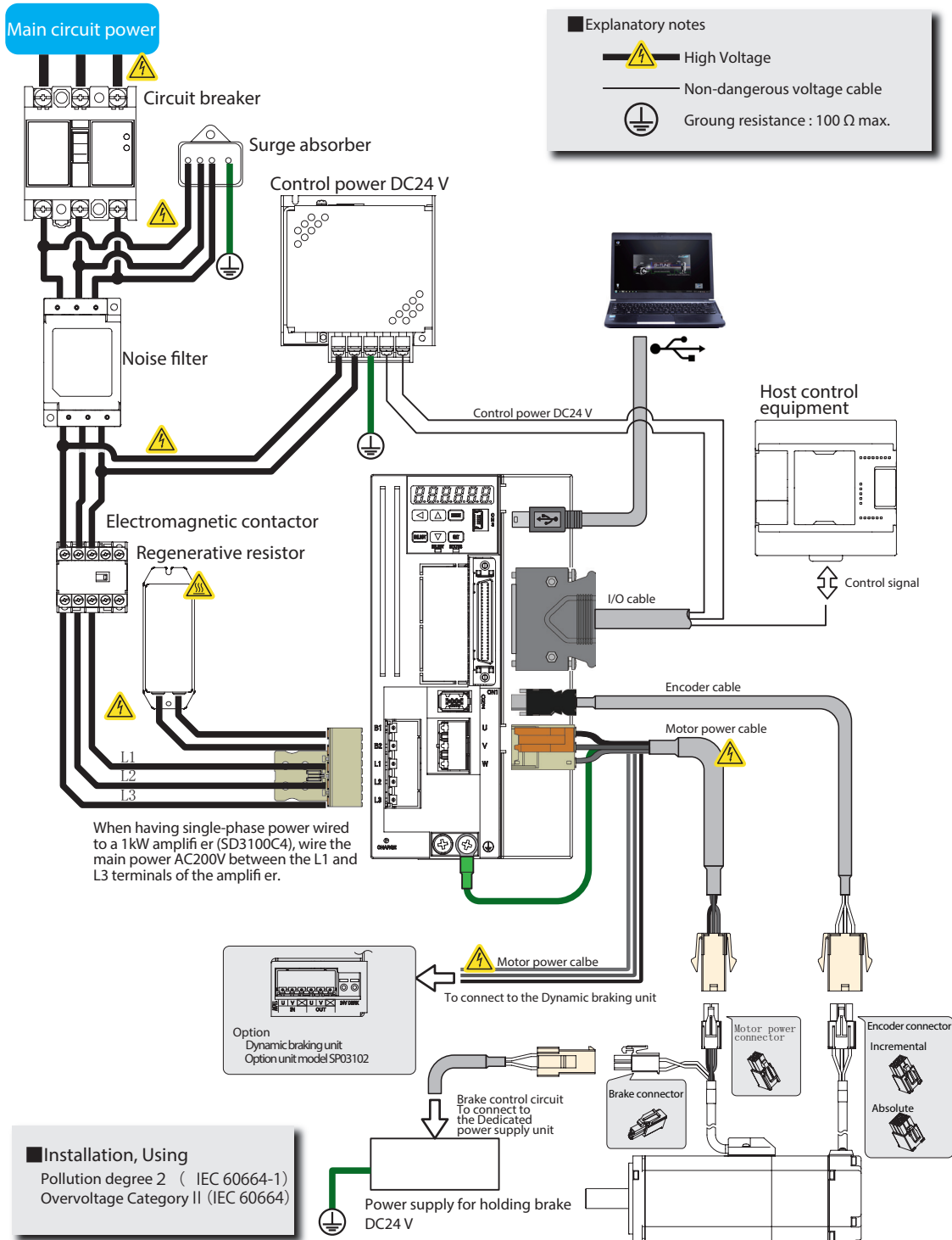

Installation, Using

Pollution degree 2 (IEC 60664-1)

Overvoltage Category II (IEC 60664)

07 SYSTEM WIRING

Wiring Pattern 4

50W

100W

200W

400W

750W

1kW

1.5kW

2kW

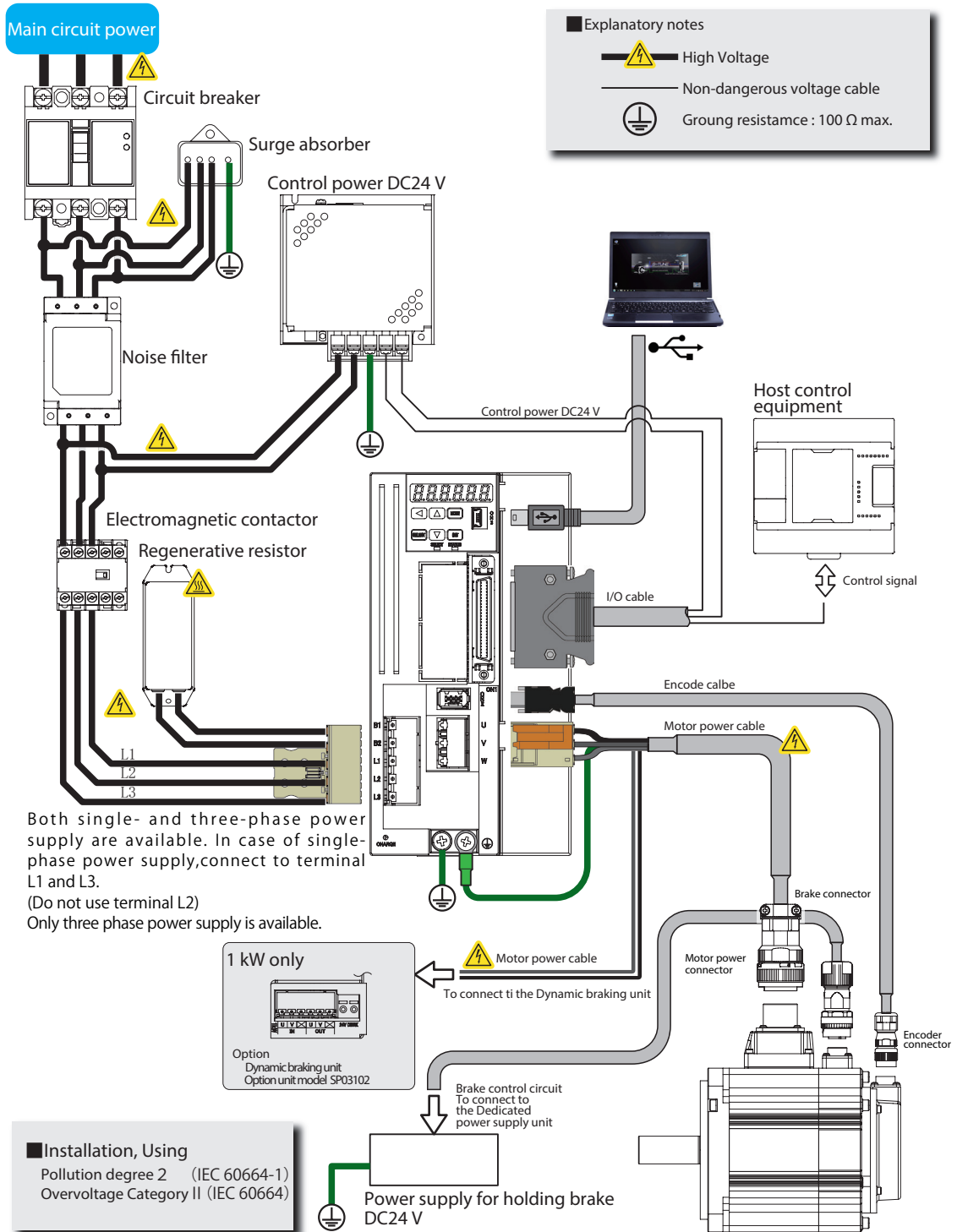

07 SYSTEM WIRING

Peripherals

To make your applications of our product comply with the European EC directives, select devices that meet each applicable standard and install them observing the wiring diagram.

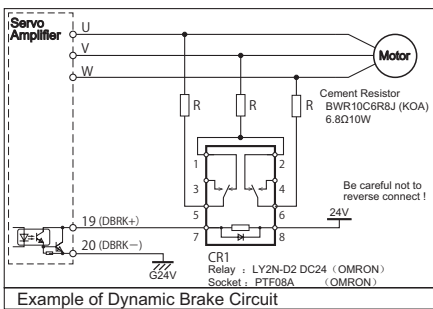
Item	Description
Main circuit power	<p>Please use this product in the power supply environment of Over-Voltage Category II defined by IEC60664-1. This is the primary circuit power for amplifiers.</p> <p>50 W to 750 W Amplifiers : Single-phase AC200 V – 10% to AC240 V +10% 1 kW to 2 kW Amplifiers : Three-phase AC200 V – 10% to AC240 V +10%</p> <p>Using a overvoltage protection relay is recommended.</p> <ul style="list-style-type: none"> • When having single-phase power wired to a 1 kW amplifier, wire the primary circuit AC200 V between the L1 and L3 terminals of the amplifier. • To avoid unbalance of the three-phase AC200 V wiring in your factory, we recommend that you consider balance of currencies in your three-phase wirings. • Confirm that your contract with the electric power company is not limited to use of three-phase.
Control power	<p>This is power supply of DC24 V ± 10 % for amplifier control power, I/O power and motor brake release power. Use a SELV (Safety Extra Low Voltage) power supply with reinforced insulation against hazardous voltages. Be sure to connect a varistor to the motor braking release power supply.</p>
Cables	<p>Use of UL wires and cables suitable for motor rated output are recommended.</p> <p>High-voltage cables and FG cables AWG18 / 600 V breakdown voltage or equivalent for 50 W to 750 W AWG14 / 600 V breakdown voltage or equivalent for 1 kW to 2 kW</p> <p>Motor power cables AWG18 / 300 V breakdown voltage or equivalent for 50 W to 750 W AWG14 / 300 V breakdown voltage or equivalent for 1 kW to 2 kW</p> <p>Encoder cables <ul style="list-style-type: none"> • AWG22 and AWG24 compound / 30 V breakdown voltage or equivalent • shielded cables with twisted pair wires • length not exceeding 20 m </p> <p>User I/O cable <ul style="list-style-type: none"> • AWG26 / 300 V breakdown voltage or equivalent • shielded cables with twisted pair wires • length not exceeding 2 m </p>
Circuit breaker	<p>To protect the power supply line, circuit breakers shut the circuit down in the event of over-current. Be sure to use an IEC standard and UL-certified circuit breaker between the power supply and the noise filter. To ensure compliance with EMC, use an earth leakage circuit breaker that we recommend.</p>
Noise filter	<p>Noise filters prevent ingress of external noise from the power supply line. To ensure compliance with EMC, use the recommended noise filter.</p>
Electromagnetic contactor	<p>This is an on/off switch for the main power supply. Use a surge absorber on the input side of the primary circuit power supply.</p>
Surge absorber	<p>To ensure compliance with EMC, connect the recommended surge absorber to the primary side of primary circuit power supply.</p>
Signal line noise filter/ferrite core	<p>To ensure compliance with EMC, use the recommended signal line noise filter/ferrite core.</p>
Regenerative resistor	<p>This product is not equipped with regenerative resistor. If the smoothing capacitor inside the servo amplifier cannot absorb regenerative power, an external regenerative resistor is required. As a guideline, check the regeneration state on the settings panel, and use a regenerative resistor if the regenerative voltage warning is ON. Build an overheating prevention circuit using a resistor which has built-in thermostat. If the temperature of generated heat becomes high, you can suppress the heat by installing a cooling device, or selecting a resistor whose allowable power is 5 to 10 times larger than regenerative voltage.</p>
Dynamic brake	<p>This product is not equipped with a dynamic brake feature. Use our optional product for 50 W to 1 kW Model AP03101 (50 W to 750 W), Model AP03102 (1 kW). See Optional manual Dynamic brake unit</p> <p>Use the circuit example on the right side when building a dynamic brake circuit.</p> <p>Select a cement resistor of 6.8 Ω 10 W. Select coil surge protection relays with diode. For wiring with the motor power line, UL wires (AWG18 / 600 V or equivalent) are recommended.</p>  <p>Example of Dynamic Brake Circuit</p>
Grounding	<p>Since this product is Class I device, protective grounding is mandatory. (Type D grounding: grounding resistance of up to 100 Ω) Properly ground the product using protective grounding terminals through EMC-compatible casing and control panel.</p>

Recommended Peripheral Devices

Device	Manufacturer	Model	Note
Circuit breaker	Fuji Electric Co Ltd	Single-phase : EW32AAG-2P020B Three-phase : EW32AAG-3P020B	20 A for single-phase or three-phase 200 V ^(*) Leakage current of 30 mA, Equivalent products are acceptable.
Noise filter	OKAYA Electric Industries Co Ltd	Single-phase : SUPF-EX □□ -ER-6 Three-phase : 3SUPF-BE □□ -ER-6- □	Was used in the EMC testing for our product ^(*)
Magnetic contactor	Fuji Electric Co Ltd	SK06G-E10	Or equivalent alternatives.
Surge absorber	OKAYA Electric Industries Co Ltd	Single-phase : LV275DI-Q4 Three-phase : LV275DI-U4	Was used in the EMC testing for our product
Signal line noise filter /ferrite core	SEIWA ELECTRIC MFG. CO., LTD. (Misumi Corporation)	E04SR401938 (ATCK-1130)	Was used in the EMC testing for our product
Regenerative resistor	Chiba Techno Co., Ltd.	For 50 W to 750 W : CAN100S 47 Ω J For 1 kW, 1.5 kW : CAN400S 30 Ω J For 2 kW : CAN750S 20 Ω J	-

*) Select a product whose ratings are suitable for your system configuration.

Regenerative Resistor

When considering a regenerative resistor other than the recommended above, use the following as a guideline.

Amplifier Model	SD3005CY**	SD3010CZ**	SD3020C1**	SD3040C2**	SD3080C3**	SD3100C4**	SD3150C6**	SD3200C8**
Compatible Motor	M □□ 005	M □□ 010	M □□ 020	M □□ 040	M □□ 075	M □□ 100	M □□ 150	M □□ 200
Rated output	50 W	100 W	200 W	400 W	750 W	1 kW	1.5 kW	2 kW
Regeneration resistance	40 Ω to 50 Ω					30 Ω		20 Ω
Regeneration allowable voltage	20 W					40 W		60 W

The regeneration resistance values do not guarantee the optimal performance. Regeneration allowable voltages above are minimum values as a point of reference.

The regeneration resistor may become very hot. It requires sufficient margin of regeneration allowable power.

Recommended Cables

Connection cables required for this product are sold separately. Those can be purchased at the Misumi Corporation online store. Follow the link at our website:

Use our recommendations below to select cables based on your actual usage. (Equivalent alternatives are also good)

Cable Name	AWG	UL	Temperature Rating	Voltage Rating	Note
Motor power (≤ 750 W)	18	2517	105 °C	300 V	
Motor power (≥ 1 kW)	14	2517	105 °C	300 V	AWG16 wires can be used only for 1 kW motors
Main circuit power (≤ 750 W) (Including FG cable)	18	1015	105 °C	600 V	
Main circuit power (≥ 1 kW) (Including FG cable)	14	1015	105 °C	600 V	AWG16 wires can be used only for 1 kW motors.
Encoder	Power : 22 Signal : 24	20276	80 °C	30 V	Shielded twisted pair cables of length no exceeding 20 m
User I/O	26	1007	80 °C	300 V	Shielded twisted pair cables Length not exceeding 2 m is recommended
Regenerative resistor	18	1015	105 °C	600 V	
Dynamic brake	18	1015	105 °C	600 V	
Brake	18	2517	105 °C	300 V	1 pair (2 cores)

08 CONNECTORS

Motor

50W

100W

200W

400W

750W

1kW

1.5kW

2kW

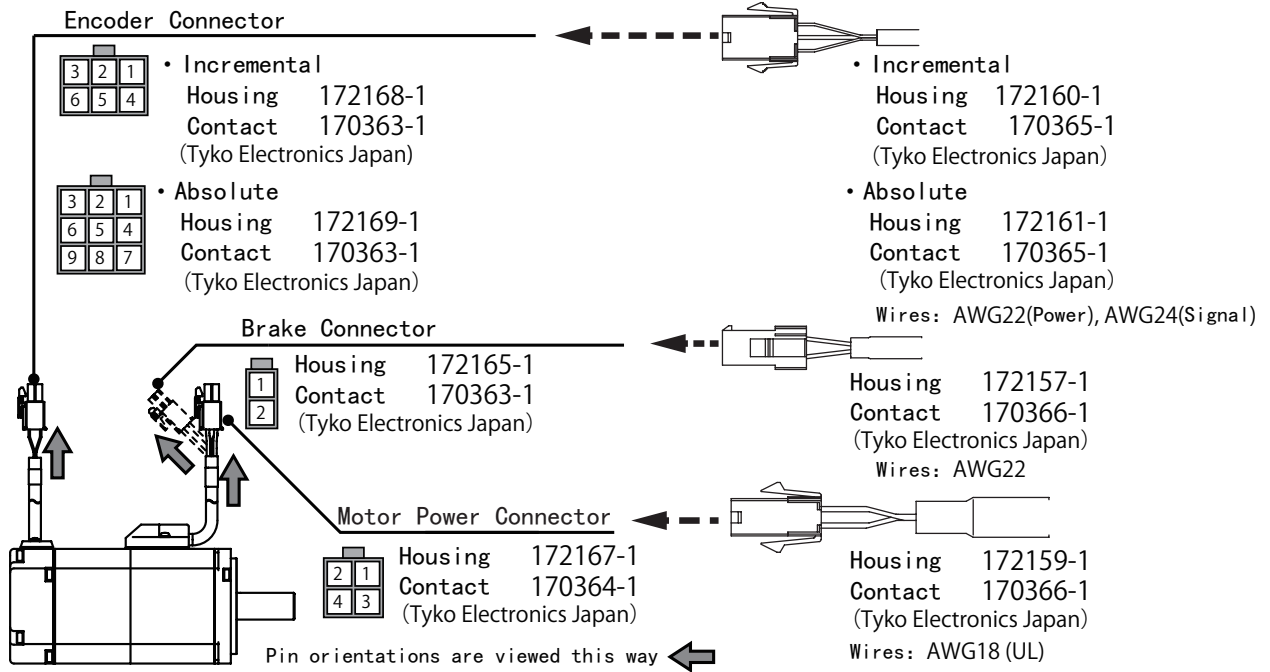

Name	Pin No.	Signal	Description
Motor Power	1	U	Motor power U-phase
	2	V	Motor power V-phase
	3	W	Motor power W-phase
	4	FG	Motor frame ground
Brake ^{(*)1}	1	BRK+	Brake power supply DC24 V
	2	BRK-	Brake power supply GND
Encoder (Incremental)	1	-	(No Connect)
	2	+D	Serial communication data + Data
	3	-D	Serial communication data - Data
	4	VCC	Encoder power supply +5 V
	5	SG	Signal ground
	6	SHIELD	Shield
Encoder (Absolute)	1	BAT	External battery ^{(*)2}
	2	-	(No Connect)
	3	SHIELD	Shield
	4	+D	Serial communication data + Data
	5	-D	Serial communication data - Data
	6	-	(No Connect)
	7	VCC	Encoder power supply +5 V
	8	SG	Signal ground
	9	-	(No Connect)

*1) Only for a motor equipped with a brake

*2) Connect the negative pole of the battery to SG (Signal Ground).

08 CONNECTORS

Motor

50W

100W

200W

400W

750W

1kW

1.5kW

2kW

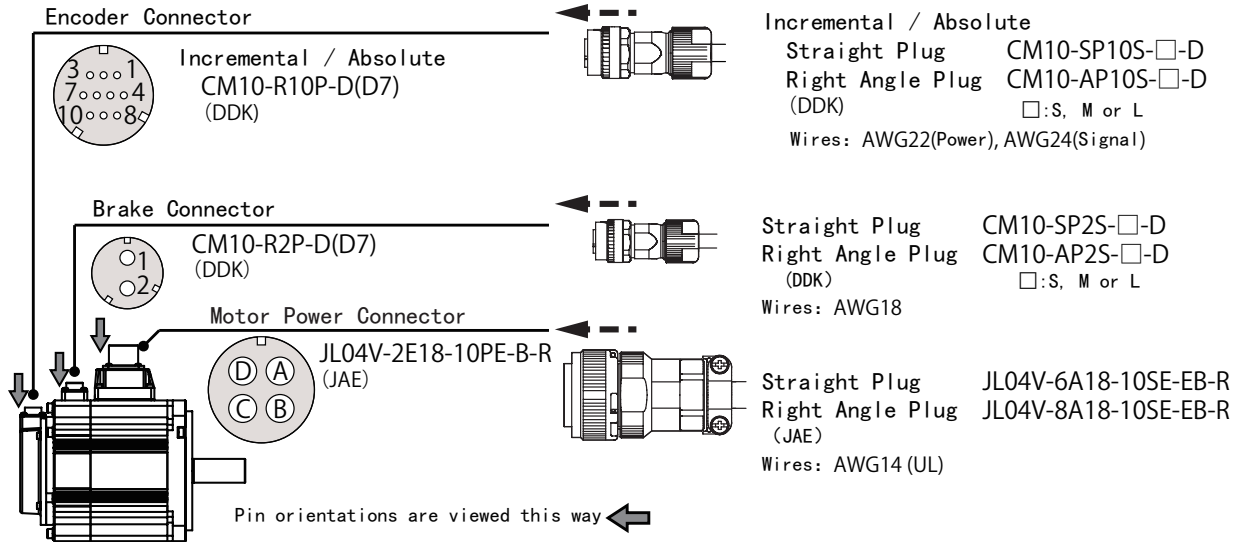

Name	Pin No.	Signal	Description
Motor Power	A	U	Motor power U-phase
	B	V	Motor power V-phase
	C	W	Motor power W-phase
	D	FG	Motor frame ground
Brake ^{(*)1}	1	BRK+	Brake power supply DC24 V
	2	BRK-	Brake power supply GND
Encoder (Incremental)	1	VCC	Encoder power supply +5 V
	2	SG	Signal ground
	3,4	-	(No Connect)
	5	+D	Serial communication data + Data
	6	-D	Serial communication data - Data
	7,8,9	-	(No Connect)
Encoder (Absolute)	10	SHIELD	Shield
	1	VCC	Encoder power supply +5 V
	2	SG	Signal ground
	3	-	(No Connect)
	4	BAT	External battery ^{(*)2}
	5	+D	Serial communication data + Data
	6	-D	Serial communication data - Data
	7,8	-	(No Connect)
9	SG	Signal ground	
10	SHIELD	Shield	

*1) Only for a motor equipped with a brake

*2) Connect the negative pole of the battery to SG (Signal Ground).

08 CONNECTORS

Amplifier

50W 100W 200W 400W 750W 1kW 1.5kW 2kW

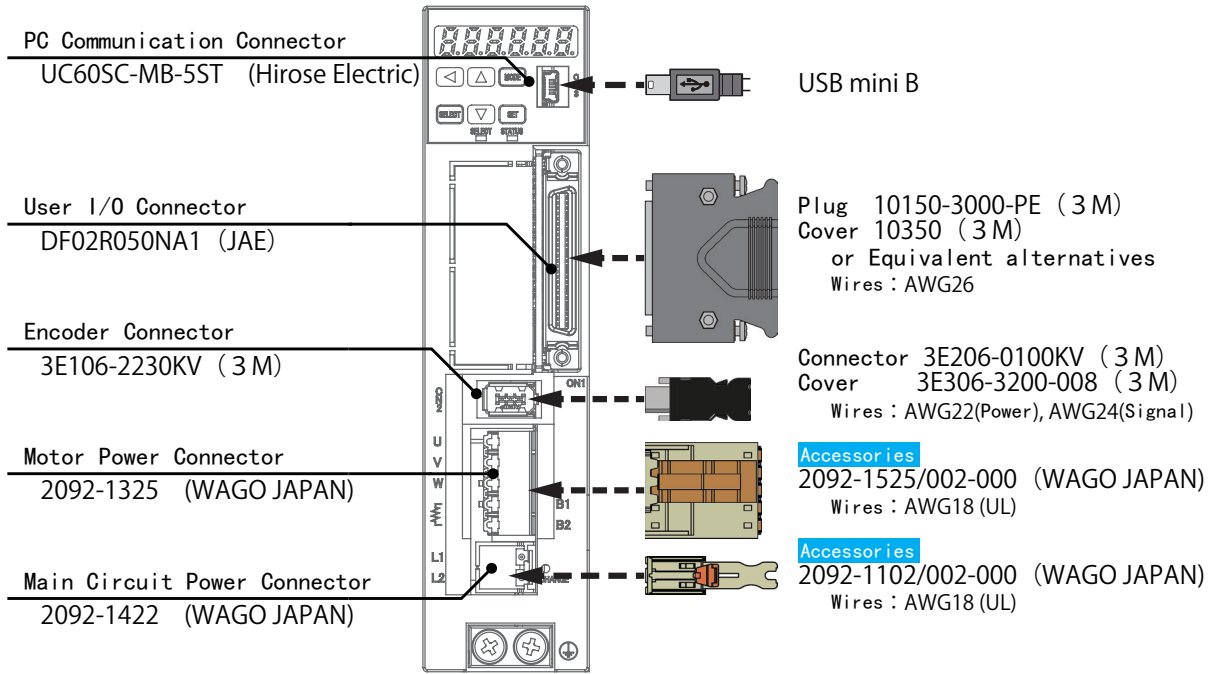

Name	Code	Pin No.	Signal	Description
Main Circuit Power	L1L2	1	L1	Main power cable 1
		2	L2	Main power cable 2
Motor Power	UVW / B1B2	1	U	Motor power U-phase
		2	V	Motor power V-phase
		3	W	Motor power W-phase
		4	B1	Regenerative resistor connection (+)
		5	B2	Regenerative resistor connection (-)
Encoder	CN2	1	VCC	Encoder power supply +5 V
		2	GND	Signal ground
		3, 4	-	(No Connect)
		5	+D	Serial communication data + Data
		6	-D	Serial communication data - Data
		-	FG	SHIELD wired to the connector casing
PC Communication	CN3	1	VBUS	USB power supply +5 V
		2	D-	USB data -
		3	D+	USB data +
		4	-	(No Connect)
		5	GND	USB signal ground
User I/O	CN1	Route power and signal wiring suitable for your operation mode. (See "Example of I/O Wiring")		

08 CONNECTORS

Amplifier

50W

100W

200W

400W

750W

1kW

1.5kW

2kW

PC Communication Connector
UC60SC-MB-5ST (Hirose Electric)

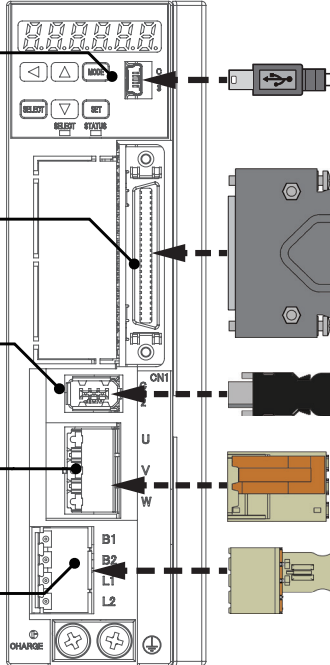

USB mini B

User I/O Connector
DF02R050NA1 (JAE)

Plug 10150-3000-PE (3 M)
Cover 10350 (3 M)
or Equivalent alternatives
Wires : AWG26

Encoder Connector
3E106-2230KV (3 M)

Connector 3E206-0100KV (3 M)
Cover 3E306-3200-008 (3 M)
Wires : AWG22(Power), AWG24(Signal)

Motor Power Connector
2092-3323 (WAGO JAPAN)

Accessories
2092-3523/002-000 (WAGO JAPAN)
Wires : AWG18 (UL)

Main Circuit Power Connector
2092-1424 (WAGO JAPAN)

Accessories
2092-1104/002-000 (WAGO JAPAN)
Wires : AWG18 (UL)

Name	Code	Pin No.	Signal	Description
Main Circuit Power	L1L2 / B1B2	1	B1	Regenerative resistor connection (+)
		2	B2	Regenerative resistor connection (-)
		3	L1	Main power cable 1
		4	L2	Main power cable 2
Motor Power	UVW	1	U	Motor power U-phase
		2	V	Motor power V-phase
		3	W	Motor power W-phase
Encoder	CN2	1	VCC	Encoder power supply +5 V
		2	GND	Signal ground
		3, 4	-	(No Connect)
		5	+D	Serial communication data + Data
		6	-D	Serial communication data - Data
		-	FG	SHIELD wired to the connector casing
PC Communication	CN3	1	VBUS	USB power supply +5 V
		2	D-	USB data -
		3	D+	USB data +
		4	-	(No Connect)
		5	GND	USB signal ground
User I/O	CN1	Route power and signal wiring suitable for your operation mode. (See "Example of I/O Wiring")		

08 CONNECTORS

Amplifier

50W

100W

200W

400W

750W

1kW

1.5kW

2kW

PC Communication Connector

UC60SC-MB-5ST (Hirose Electric)

USB mini B

User I/O Connector

DF02R050NA1 (JAE)

Plug 10150-3000-PE (3 M)
Cover 10350 (3 M)
or Equivalent alternatives
Wires : AWG26

Encoder Connector

3E106-2230KV (3 M)

Connector 3E206-0100KV (3 M)
Cover 3E306-3200-008 (3 M)
Wires : AWG22(Power), AWG24(Signal)

Motor Power Connector

2092-3323 (WAGO JAPAN)

Accessories
2092-3523/002-000 (WAGO JAPAN)
Wires : AWG18 (UL)

Main Circuit Power Connector

2092-3425 (WAGO JAPAN)

Accessories
2092-3105/002-000 (WAGO JAPAN)
Wires : AWG14 (UL)

Name	Code	Pin No.	Signal	Description
Main Circuit Power	L1L2L3 / B1B2	1	B1	Regenerative resistor connection (+)
		2	B2	Regenerative resistor connection (-)
		3	L1	Main power cable 1 ^{(*)1}
		4	L2	Main power cable 2 ^{(*)2}
		5	L3	Main power cable 3 ^{(*)1}
Motor Power	UVW	1	U	Motor power U-phase
		2	V	Motor power V-phase
		3	W	Motor power W-phase
Encoder	CN2	1	VCC	Encoder power supply +5 V
		2	GND	Signal ground
		3,4	-	(No Connect)
		5	+D	Serial communication data + Data
		6	-D	Serial communication data - Data
		-	FG	SHIELD wired to the connector casing
PC Communication	CN3	1	VBUS	USB power supply +5 V
		2	D-	USB data -
		3	D+	USB data +
		4	-	(No Connect)
		5	GND	USB signal ground
User I/O	CN1	Route power and signal wiring suitable for your operation mode. (See "Example of I/O Wiring")		

*1) When having single-phase power wired to 1kW amplifiers (DA24A22), connect the primary circuit power to L1 and L3.

*2) Do not connect when using with single-phase power.

09 RECOMMENDED CABLES

Motor Power Cable

50W

100W

200W

400W

750W

1kW

1.5kW

2kW

4 HOUSING

Pin No.	Signal	Color
1	U	RED
2	V	WHITE
3	W	BLUE
4	FG	GREEN - YELLOW

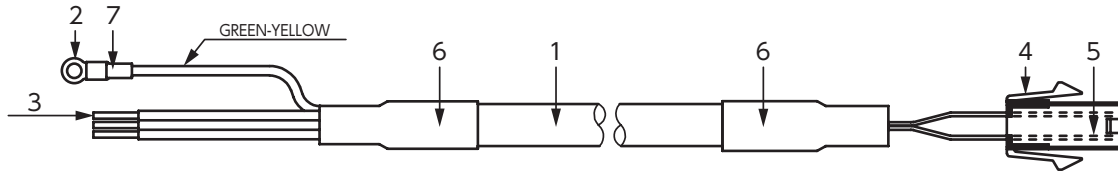

No.	Item	Model	Supplier
1	CABLE	NA3CT-18-4 (for fixed wiring) NA3CTR-18-4 (for movable wiring)	MISUMI Group Ink
2	RING TONGUE TERMINAL	R2-4	J.S.T. Mfg. Co., Ltd.
3	FERRULE	216-143	WAGO JAPAN
4	HOUSING	172159-1	Tyco Electronics JAPAN
5	TERMINAL	170366-1	Tyco Electronics JAPAN
6	SUMITUBE	F(Z) 11x0.25	Sumitomo Electric Industries
7	(MARKER TUBE)	(arbitrary)	(arbitrary)

Motor Power Cable

50W

100W

200W

400W

750W

1kW

1.5kW

2kW

4 PLUG

Pin No.	Signal	Color
1	U	RED
2	V	WHITE
3	W	BLUE
4	FG	GREEN - YELLOW

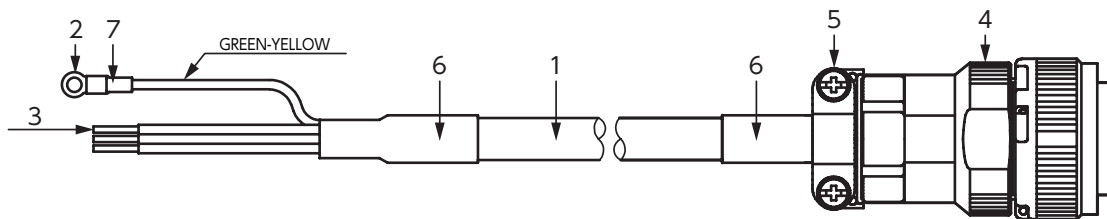

No.	Item	Model	Supplier
1	CABLE	NA6CT-14-4 (for fixed wiring) NA6CTR-14-4 (for movable wiring)	MISUMI Group Ink
2	RING TONGUE TERMINAL	R2-4	J.S.T. Mfg. Co., Ltd.
3	FERRULE	216-106	WAGO JAPAN
4	PLUG	JL04V-6A18-10SE-EB-R	JAE
5	CABLE CLAMP	JL04V-18CK13-CR-R	JAE
6	SUMITUBE	F(Z) 14x0.3	Sumitomo Electric Industries
7	(MARKER TUBE)	(arbitrary)	(arbitrary)

09 RECOMMENDED CABLES

Encoder Cable (Incremental)

50W 100W 200W 400W 750W 1kW 1.5kW 2kW

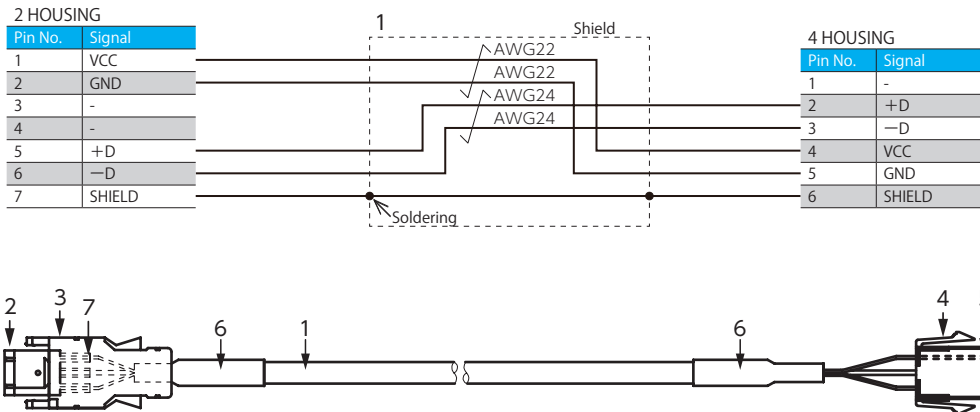

No.	Item	Model	Supplier
1	CABLE	NA20276TSB-C (for fixed wiring) NA20276RRSB-C (for movable wiring)	MISUMI Group Ink
2	HOUSING	3E206-0100KV	3M
3	COVER	3E306-3200-008	3M
4	HOUSING	172160-1	Tyco Electronics JAPAN
5	TERMINAL	170365-1	Tyco Electronics JAPAN
6	SUMITUBE	F(Z) 7x0.25	Sumitomo Electric Industries
7	SUMITUBE	F(Z) 3/64 or 1.5x0.2	Sumitomo Electric Industries

Encoder Cable (Incremental)

50W 100W 200W 400W 750W 1kW 1.5kW 2kW

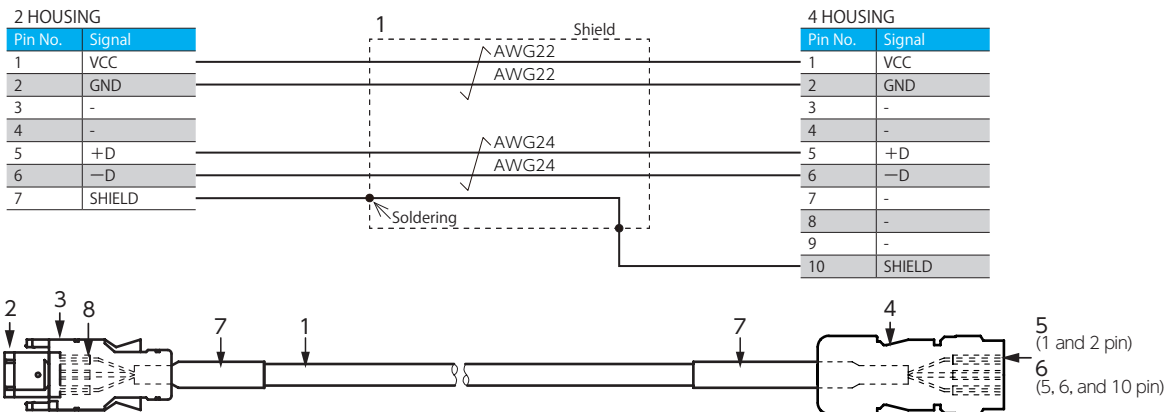

No.	Item	Model	Supplier
1	CABLE	NA20276TSB-C (for fixed wiring) NA20276RRSB-C (for movable wiring)	MISUMI Group Ink
2	HOUSING	3E206-0100KV	3M
3	COVER	3E306-3200-008	3M
4	HOUSING	CM10-SP10S-M	DDK
5	TERMINAL	CM10-#22SC(C1)(D8)	DDK
6	TERMINAL	CM10-#22SC(C2)(D8)	DDK
7	SUMITUBE	F(Z) 7x0.25	Sumitomo Electric Industries
8	SUMITUBE	F(Z) 3/64 or 1.5x0.2	Sumitomo Electric Industries

09 RECOMMENDED CABLES

Encoder Cable (Absolute)

50W

100W

200W

400W

750W

1kW

1.5kW

2kW

(Absolute)

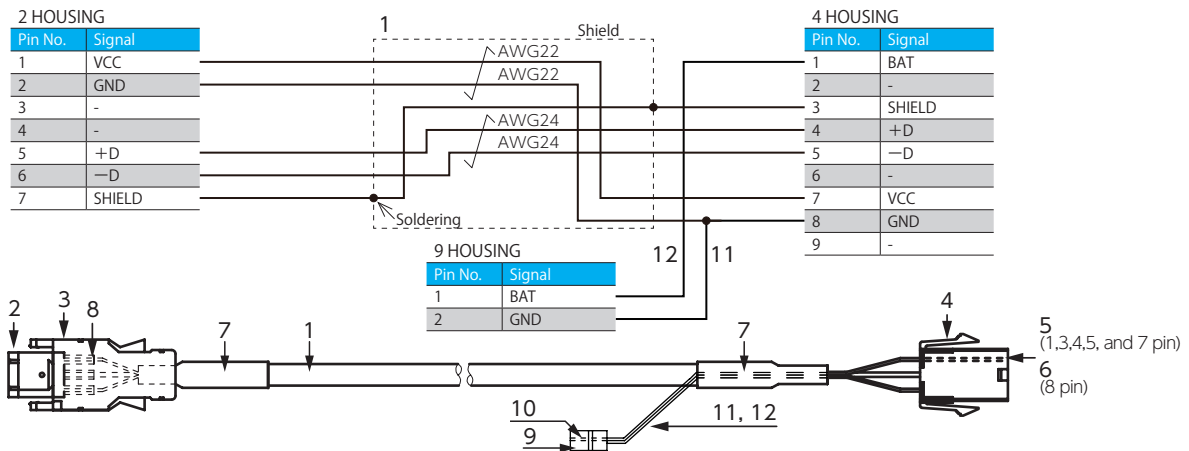

No.	Item	Model	Supplier
1	CABLE	NA20276TSB-C (for fixed wiring) NA20276RRSB-C (for movable wiring)	MISUMI Group Ink
2	HOUSING	3E206-0100KV	3M
3	COVER	3E306-3200-008	3M
4	HOUSING	172161-1	Tyco Electronics JAPAN
5	TERMINAL	170365-1	Tyco Electronics JAPAN
6	TERMINAL	170366-1	Tyco Electronics JAPAN
7	SUMITUBE	F(Z) 7x0.25	Sumitomo Electric Industries
8	SUMITUBE	F(Z) 3/64 or 1.5x0.2	Sumitomo Electric Industries
9	HOUSING	DF3-2EP-2C	Hirose Electric
10	TERMINAL	DF3-EP2428PCFA	Hirose Electric
11	CABLE	NAUL1007-24-BK	MISUMI Group Ink
12	CABLE	NAUL1007-24-R	MISUMI Group Ink

Encoder Cable (Absolute)

50W

100W

200W

400W

750W

1kW

1.5kW

2kW

(Absolute)

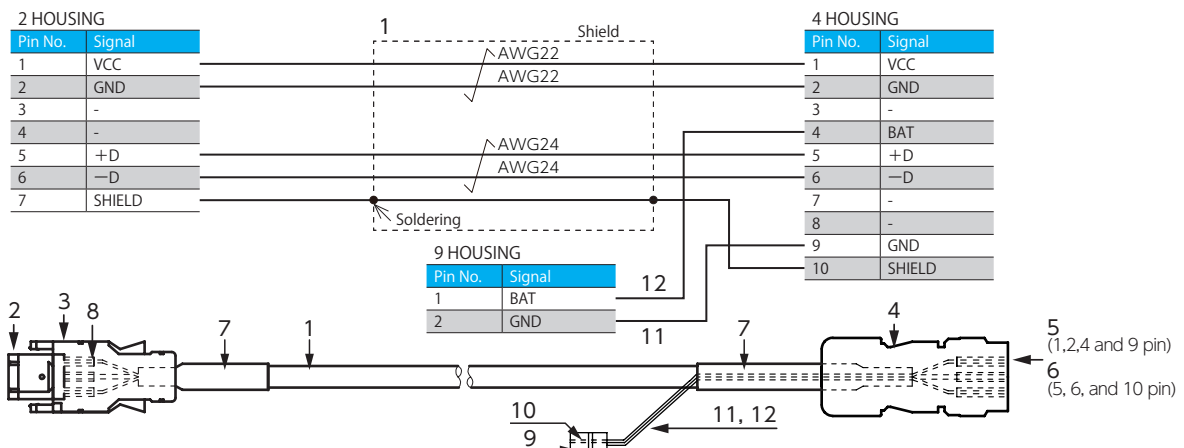

No.	Item	Model	Supplier
1	CABLE	NA20276TSB-C (for fixed wiring) NA20276RRSB-C (for movable wiring)	MISUMI Group Ink
2	HOUSING	3E206-0100KV	3M
3	COVER	3E306-3200-008	3M
4	HOUSING	CM10-SP105-M	DDK
5	TERMINAL	CM10-#225C(C1)(D8)	DDK
6	TERMINAL	CM10-#225C(C2)(D8)	DDK
7	SUMITUBE	F(Z) 7x0.25	Sumitomo Electric Industries
8	SUMITUBE	F(Z) 3/64 or 1.5x0.2	Sumitomo Electric Industries
9	HOUSING	DF3-2EP-2C	Hirose Electric
10	TERMINAL	DF3-EP2428PCFA	Hirose Electric
11	CABLE	NAUL1007-24-BK	MISUMI Group Ink
12	CABLE	NAUL1007-24-R	MISUMI Group Ink

09 RECOMMENDED CABLES

Brake Cable

50W 100W 200W 400W 750W 1kW 1.5kW 2kW

2 HOUSING

Pin No.	Signal	Color
1	BRK+	BRACK
2	BRK-	BRACK

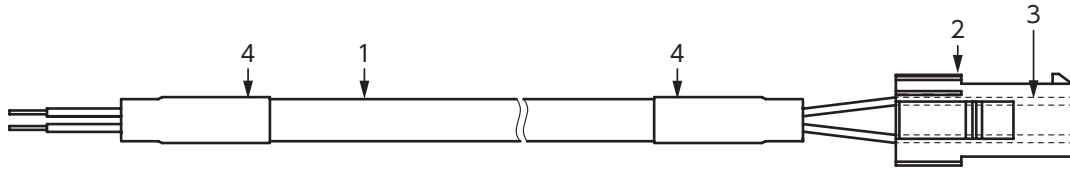

No.	Item	Model	Supplier
1	CABLE	MAST-UL2517-19-2(for fixed wiring) NA3UCR-18-2 (for movable wiring)	MISUMI Group Ink
2	HOUSING	172157-1	Tyco Electronics JAPAN
3	TERMINAL	170366-1 or 170639-1	Tyco Electronics JAPAN
4	SUMITUBE	F(Z) 8x0.25	Sumitomo Electric Industries

Brake Cable

50W 100W 200W 400W 750W 1kW 1.5kW 2kW

2 PLUG

Pin No.	Signal	Color
1	BRK+	BRACK
2	BRK-	BRACK

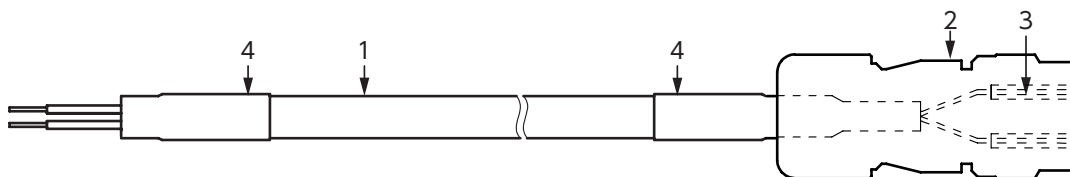

No.	Item	Model	Supplier
1	CABLE	MAST-UL2517-19-2(for fixed wiring) NA3UCR-18-2 (for movable wiring)	MISUMI Group Ink
2	PLUG	CM10-SP2S-M-D	DDK
3	CONTACT	CM10-#225C(S2)(D8)-100	DDK
4	SUMITUBE	F(Z) 8x0.25	Sumitomo Electric Industries

Pulse Input Command | Differential Input (Standard I/O)

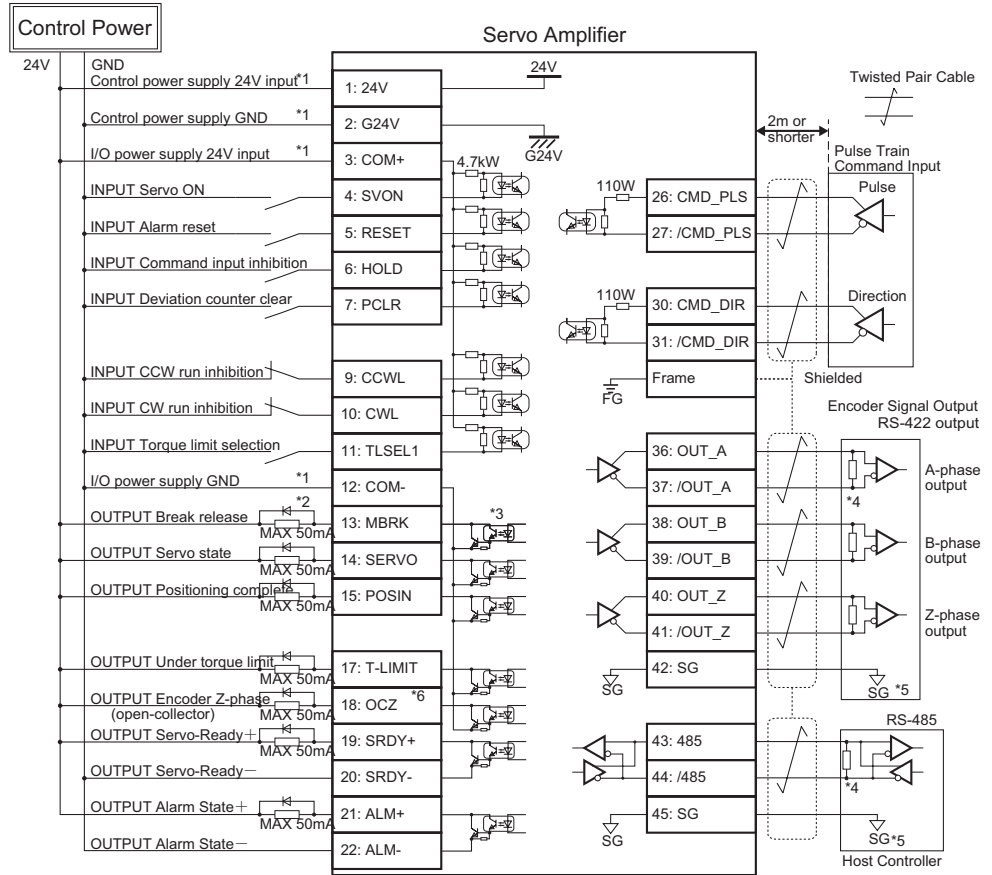

Pulse Input Command | Differential Input (Optional I/O)

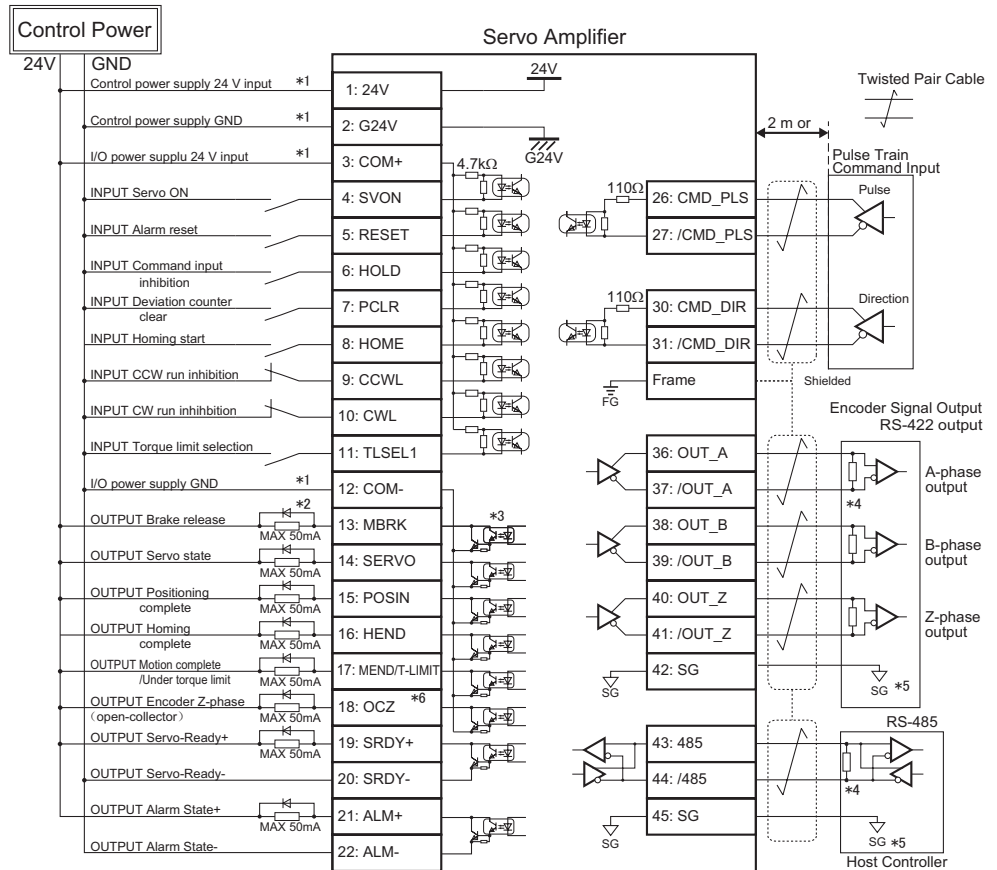

Pulse Input Command | 24V Open Collector Input

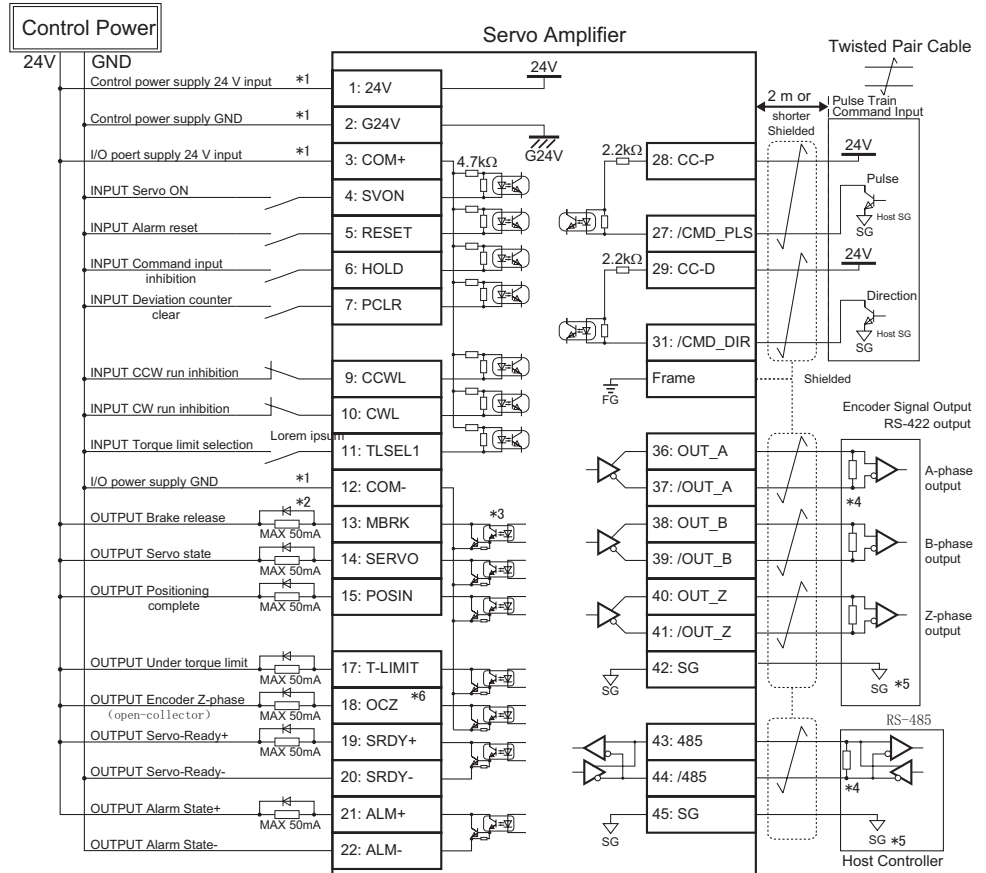

Pulse Input Command | 5V Open Collector Input

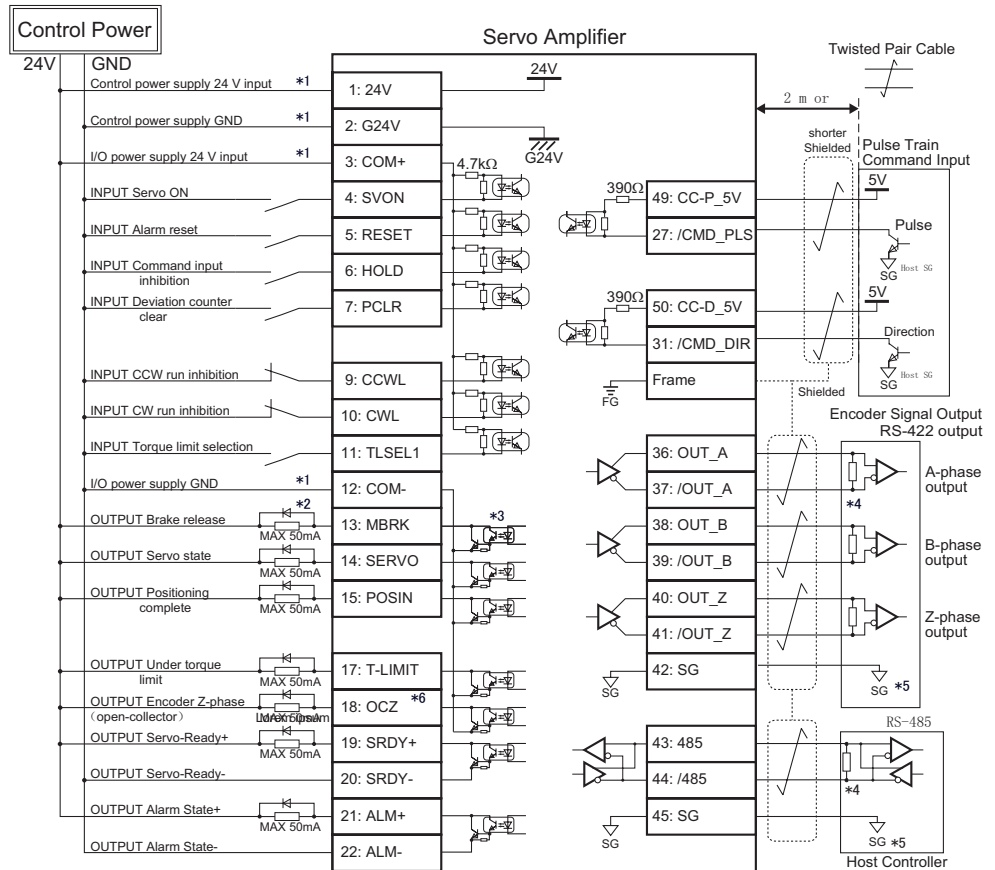

Internal Position Command | Standard I/O

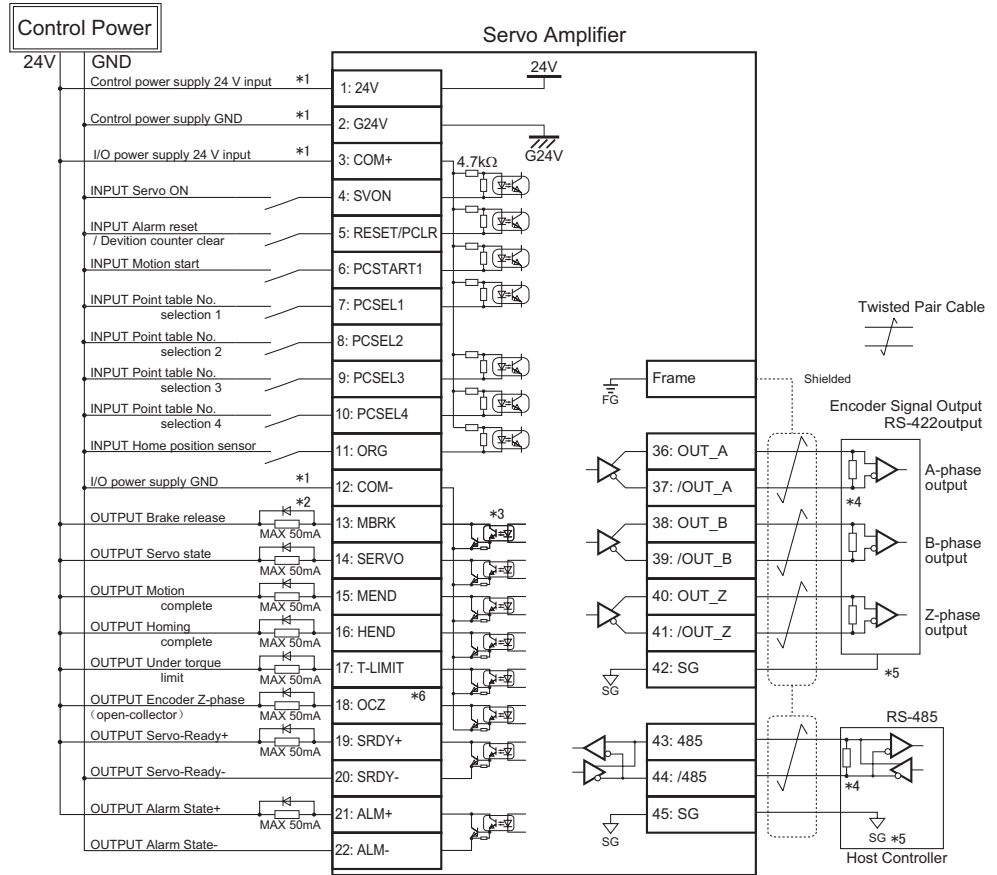

Internal Position Command | Optional I/O

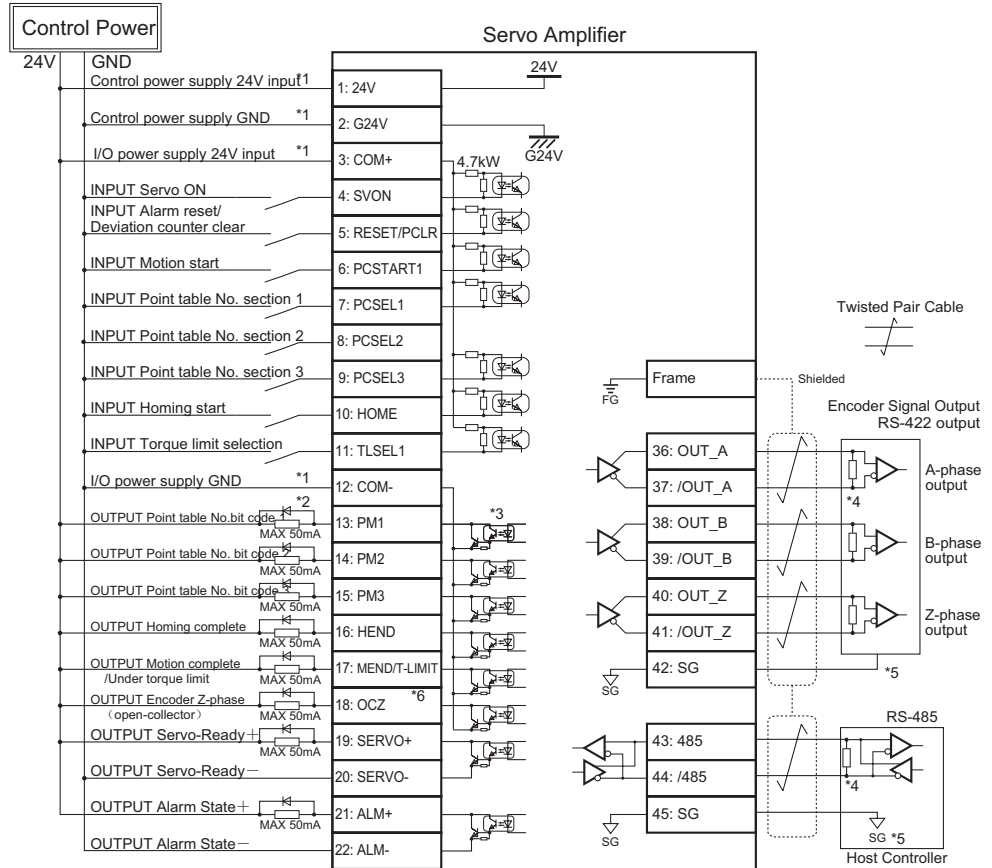

Analog Velocity Command

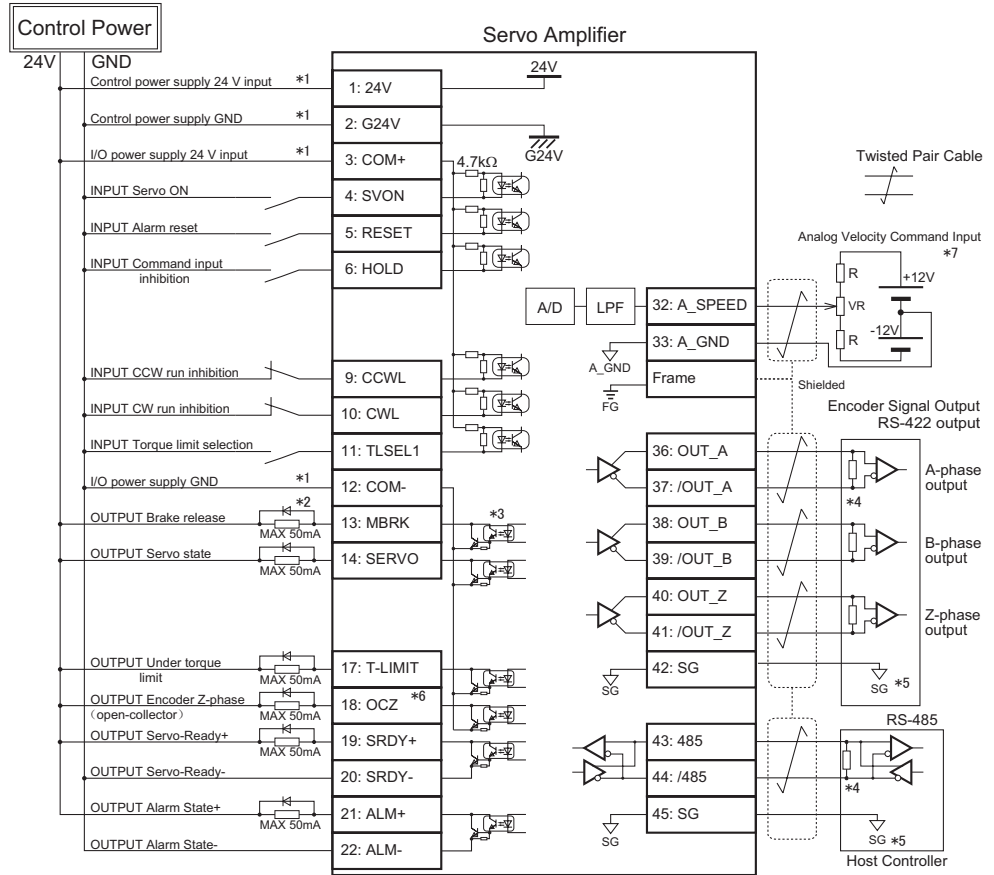

Internal Velocity Command

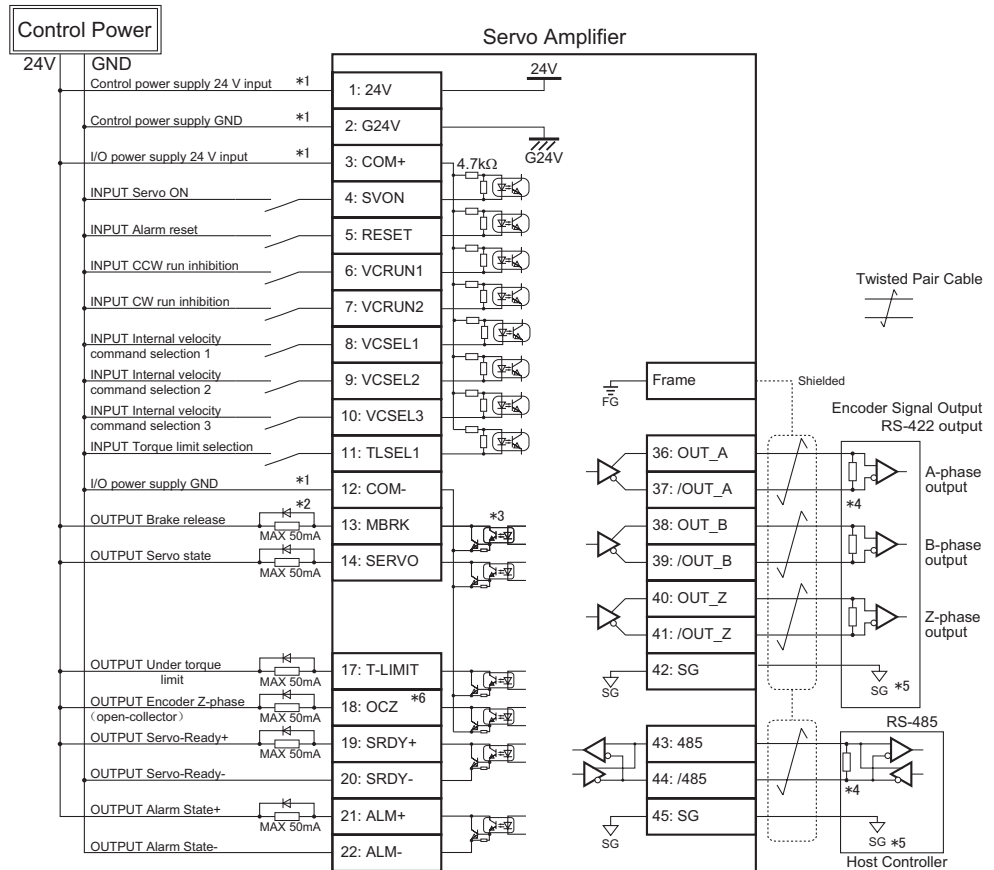

Analog Torque Command

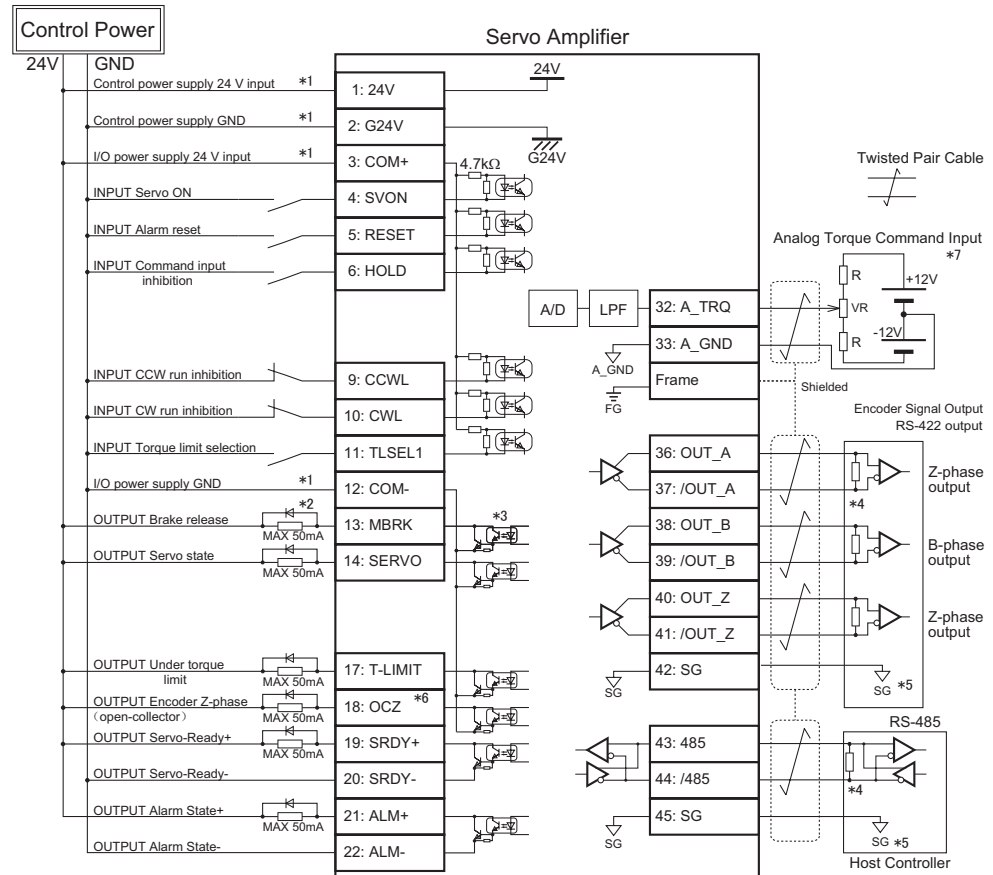

Notes:

- *1) Have only one power supply for both the control power (24 V, G24 V) and I/O power (COM+, COM-).
- *2) When driving a load which contains inductance element (e.g. relay), connect a protection diode. Motor brake can not be directly engaged. Be sure to use a relay with a protection diode in the circuit.
- *3) The output circuit structure is open connector and Darlington connection transistor output and connects to relay or photocoupler. Note that when Transistor ON, connector-emitter voltage V_{CE} (SAT) is approximately 1 V, which does not satisfy V_{IL} of regular TTL IC. Hence, the output circuit structure must not be connected directly.
- *4) Be sure to connect a terminating resistor of around 220 Ω .
- *5) Connect to the communication I/O signal ground of the host controller which outputs amplifier encoder output signal. Connecting the signal ground to the amplifier control power GND might result in malfunction.
- *6) When Z-phase pulse width is too narrow to be recognized by the host controller accurately, decrease the paired-pulse ratio "Encoder pulse output Division and multiplication" with parameters No. 276.0 and No. 278.0, or reduce the number of rotations, so that the pulse width becomes wider.
Pulse width ms = Pulse width ms = $2 / (\text{the number of rotations}) / (\text{the paired-pulse ratio} \times 2^{17}) \times 60 \times 1,000$
- *7) When building a command circuit with a variable resistor (VR) and a resistor (R), in order to have the range of command input voltage to be -10 V to +10 V, VR should be at least 2 kΩ 1/4 W and R should be at least 100 Ω to 200 Ω 1/4 W. When the host analog velocity command circuit is isolated from the 24 V control power, connect A_GND to the host SG, not to the control power GND. If not isolated, connect A_GND to the control power GND.

Signs below indicate two severity levels of bodily injury/loss, or property damage that could be caused by failure to observe the precautions and improper use of this product.

Symbols below indicate two types of precautions that users must follow.



Identifies information about imminent hazards that are likely to cause death or serious injury.



Safety Precautions - Don'ts



Identifies information about hazards that could cause injury or property damage.



Safety Precautions - Dos

The following signs identify information about anticipated hazards.



Danger and Caution

Causes unexpected motions, unstable motions, or uncontrollable motions
Hampers optimal performance of the product, or shortens its service life



Fire hazard



Electric shock hazard



Injury hazard



Burns hazard



Failure and damage hazard

DANGER

Symbol	Precautions (Dos and Don'ts)	Anticipated Hazards
Installation & Wiring		
	Never connect your SD3 motor directly to commercial power supply.	
	No flammables away near your SD3 motor and amplifier.	
	Be sure to protect the amplifier with a protective enclosure and allow the required clearance around the amplifier (as specified in the SD3 instruction manual) from the enclosure or any devices.	
	Install your SD3 in a location with little dust, and free from water or oil splash.	
	Mount the motor or amplifier on nonflammable surface such as metal.	
	Be sure to have any wiring work carried out by an electrician.	
	Always ground the FG terminals of the motors and amplifiers.	
	When working with wires, always turn off the circuit breakers first, carry out the work properly and methodically.	
	Be sure to connect all cables properly and insulate all conductors with insulating material.	
	Handling & Operation	
	Never touch the inside of amplifier.	
	Cables must not be damaged, stressed, loaded, or pinched.	
	Never touch the revolving component of the motor while it is in motion.	
	Do not use this product near flammable materials or where it could be subjected to water sprays, a corrosive atmosphere, or an atmosphere of flammable gases.	
	Do not use the product at a location which is subjected to severe vibrations or impact forces.	
	Do not use the product with any of cables being immersed in oil or water.	
	Do not carry out any wiring work or operations with wet hands.	
	When handling a shaft end key-grooved motor, do not touch the key groove with unprotected hands.	
	Do not touch the motor or the sink of amplifier as they become hot.	
	Do not have the motor driven by external force.	
Other Precautions		
	Be sure to verify safety after an earthquake.	
	Carry out mounting and installation securely, in order to prevent fire or personal injury during an earthquake.	
	Install an external emergency stop circuit so that operations can be stopped and power supplies shut down immediately upon occurrence of an emergency.	
Maintenance & Inspection		
	Never dismantle the SD3 product.	
	The amplifier has components with dangerously high voltage. Prior to each wiring or inspection work, allow more than 5 minutes (after power shuts off) for complete discharge of internal voltage.	

CAUTION

Symbol	Precautions (Dos and Don'ts)	Anticipated Hazards
Installation & Wiring		
	Do not touch the connector terminals directly with hands.	
	Do not cover the vent holes of the amplifier. Do not allow ingress of foreign matter.	
	Observe the specifications of motor/amplifier combinations.	
	For test runs, be sure to check motor movement with the motor being fixed in place and not attached to your mechanical system first, and then install the motor in the mechanical system.	
	Follow the specified mounting method and orientations.	
	Use the right mounting method that is suitable to the main body weight and the rated output of this product.	

 CAUTION

Symbol	Precautions (Dos and Don'ts)	Anticipated Hazards
Handling & Operations		
	Do not step on this product or place any heavy object on it.	
	To avoid unstable motions, never make drastic changes in tuning.	
	Do not approach your machine after power restoration following power outage. It may restart unexpectedly. Configure your machine to ensure safety of your personnel against its unexpected restarts.	
	Do not use the product where it could be exposed to direct sunlight.	
	Do not apply impact load to the product.	
	Never operate or stop the motor using the electromagnetic contactor installed on the main power supply side.	
	The brake installed in the motor is only for holding. Do not use it as a decelerating device.	 
	Do not use if the motor or amplifier is malfunctioning, broken, or damaged.	  
	Confirm that your power supply specifications comply with this product's.	
	The holding brake is not a stopping device to secure machine safety. To ensure safety, prepare a stopping device for your machinery.	
	Upon occurrence of an alarm, eliminate the cause and secure safety before resetting the alarm and restarting your machine.	
	Connect the brake control relay and the emergency stop relay in series.	 
Transportation & Storage		
	Do not store the product where it could be subjected to water, moisture, toxic gases, or liquids.	
	Do not hold the cables or the motor shaft when transporting.	 
	Do not let the product fall off or fall over during transportation or installation.	
	If the product was stored away for an extended period of time, check with our distributor.	
	Store the product in a location that meets the requirement of storage environments described in the instruction manual.	
Disposal		
	Prior to disposal of batteries, insulate them with tape or other material. Dispose of them following the local laws and regulations.	
	When disposing of the SD3 product, treat it as industrial waste.	
Maintenance & Inspection		
	Overhauls must not be done by anyone but FATEK Automation Corporation.	
	Do not turn the power supply on and off too frequently.	
	Your motor, heat sink of the amplifier, or regenerative resistor may become dangerously hot. Do not touch any of them with hands when power is on or for a while after power shutdown.	 
	If your amplifier or motor fails, shut down both of the control power supply and the main circuit power supply.	
	When not using the product for an extended period of time, be sure to turn the power off.	

Other Considerations and Precautions

Export of this product or its applications

If the end user or application of the product assumes to be involved in military activities or weapons, its export may be subject to "Foreign Exchange and Foreign Trade Law (Japan)" (or equivalent in your country). Have adequate legal reviews and follow any required export procedures.

Medical applications

Do not attempt to use this product or its application for human life related field. This product has been designed and manufactured for general industrial use and its medical applications are not allowed.

Applications for special environments or purposes such as nuclear power, aerospace and transportation

Please contact us in advance.

Applications that could cause serious accidents or damages due to our product failures

Be sure to have safety device or protection device installed before using your equipment.

Applying voltage over the rated power supply of this product

Could become fire or smoke hazard to the amplifier. Be sure to check and confirm proper wiring before turning the power on. Be particularly careful in a location such as clean room.

Operations with the motor shaft not grounded electrically

Depending on the device or installation environment, bearing noise might get increased by galvanic corrosion of the motor bearings. Carry out careful check and test on grounding.

Operations in environment under significant influences of external noise and static electricity

This product has been designed and manufactured along with extensive noise tests. However, there is a possibility of unexpected behaviors, depending on user's environment. Practice a fail-safe design and also take adequate measures to ensure safety within the range of machine motion.

Use of this product in a manner not specified by the manufacture

Such use shall void the manufacture warranty. Be mindful before you attempt to do so.

Maintenance and Inspection

Perform regular maintenance and inspections for safe use of this product. Ensure the safety before each inspection work. This product assumes the following operation conditions.

- Ambient temperature : Average annual temperature of 30 °C (not exceeding the rated temperature range)
- Maximum load factor : 80 %
- Maximum operating hours : 20 hours a day

Daily Inspection : Check the following before each operation.

- Check ambient temperature, humidity and atmosphere.
- No foreign objects or dust, especially nothing is blocking the vent holes.
- No over bent or damages of the wires.
- Power supply voltage is within the specifications.
- No foreign objects in mobile components of the device and the range of motions.
- When the power is on, there is no unusual noise or smell right after the machinery starts.

Periodic Inspection : Check for the following at least once a year.

- No loose clamp screw problems in the amplifier and motor.
- No deformation or no discoloration in the amplifier, motor, cables, and terminal blocks due to overheat
- No looseness in wiring fixings and terminal block screws

Warranty Information

Terms of Warranty

The term of warranty for this product is twelve (12) months after the date of product manufacture. However, brake equipped motors whose number of axis accelerations and decelerations exceeded the rated maximum shall not be covered by the warranty.

Conditions of Warranty

Should any failure develop during the warranty period under normal operations following the SD3 instruction manual.

However, even during the warranty period, Manufacture makes only fee-based repair if the failure is due to the following reasons:

- Misuse, improper repair, or alternation of the product
- Dropped after the purchase or damaged during transportation
- Use of this product in a manner not specified by Manufacture
- Fire, earthquake, lightning, storm and flood damage, salt damage, abnormal voltage, or any other acts of God or natural disasters
- Ingress of foreign matter such as water, oil or metal chips.

This warranty does not apply to parts or accessories that have been used longer than each rated service life.

The warranty applies to delivered products only and Manufacture shall not be liable for any indirect, incidental or consequential damage caused by the product failure or damage.

Contact to :