

# TPC-DCS101A1

10.1" WXGA Apollo Lake J3455 Pcap. Panel PC

Version: 3.1



## Features

- Widescreen 10.1" TFT LCD display, LED Backlit, WXGA 1280 \*800;
- Intel Apollo Lake Celeron J3455 processor, Quad-core 1.5Ghz;
- Multi-points (Max. up to 10 points) Projective capacitive touch, EETI controller;
- Aluminum-magnesium alloy, anodized treatment, Modular designed;
- DC 12V, optional wide voltage DC 9~36V power input;
- IO: 2\*GLAN, 4\*USB3.0, 2\*COM (DB9), 2\*HDMI;
- Intel PTT TPM2.0, support Windows 11;
- Fan-less & Slim design, Panel mount, VESA, Front IP65 protection.

## Specification

<b>Hardware &amp; System</b>	BIOS	SPI AMI EEI BIOS
	CPU	Intel Apollo Lake J3455, Quad-core 1.5Ghz, burst to 2.3Ghz
	Memory	SO-DIMM, Support DDR3L 1333/1600/1866 MHz, Max. up to 8GB
	Storage	1* M.2 2242 Key-B (SATA) SSD
	Graphic	Intel UHD Graphics 500
	Network	2* Intel I210AT GBE LAN chip (Optional wireless 3G/4G, 5G, Wi-Fi/BT, Wi-Fi 6)
	Audio	On-board Realtek ACL 662 audio controller
	Expansion	1* M.2 Key-B 3042/3052 slot, 1* M.2 2230 Key-E slot
	Watch dog	0~256 seconds programmable
	OS	Win10, Win11, Linux, Ubuntu
<b>IO interface</b>	COM	2*RS232 (Default), Optional 1* RS485 or 8*GPIO
	Ethernet	2* RJ45, 10/100/1000 Mbps
	Audio	No
	USB	4x USB3.0
	Display	2x HDMI
	Power	1x 2 pins, phenix terminal
<b>LCD Display</b>	Size/Type	10.1" TFT LCD
	Resolution	1280 * 800 (WXGA)
	Brightness	350 nits
	Backlit & Lifetime	LED backlit & 30 000hours
	View angle	85/85/85/85
<b>Touchscreen</b>	Type	Projective capacitive touchscreen
	Touch points	Multi points touch, max. up to 10 points
	Durability	>100 000 000 times
	Surface hardness	Mohs 6H
	Special treatment	Anti-fingerprint (AF)
<b>Structure</b>	Structure and surface	Magnesium-Aluminum alloy, sand blasting, anodized treatment
	Mount method	Panel mount, VESA 75/100
	Cooling system	Large area finned heat sink
	Overall dimension	259.0 * 177.0* 52.5 (mm)
	Cut-out dimension	253 * 171 (mm)
	Net weight	3.0 KG
	IP protection	Front Panel IP65
<b>Power &amp; Environmental</b>	Operating temp.	-20 ~ +70°C
	Storage temp.	-30 ~ +80°C
	Relative Humidity	10 ~ 95% @ 10C (Non-condensation)
	Vibration	50 ~ 500 Hz, 1.5G, 0.15mm peak to peak
	Shock	10G/Peak (11 ms)
	Power input	DC 12V (Optional DC 9~36V)
	Power consumption	Around 30W
	EMC	CE/ROHS/FCC Class A



DIMENSIONAL DRAWING:TPC-DCS101A/W

**Dimension**

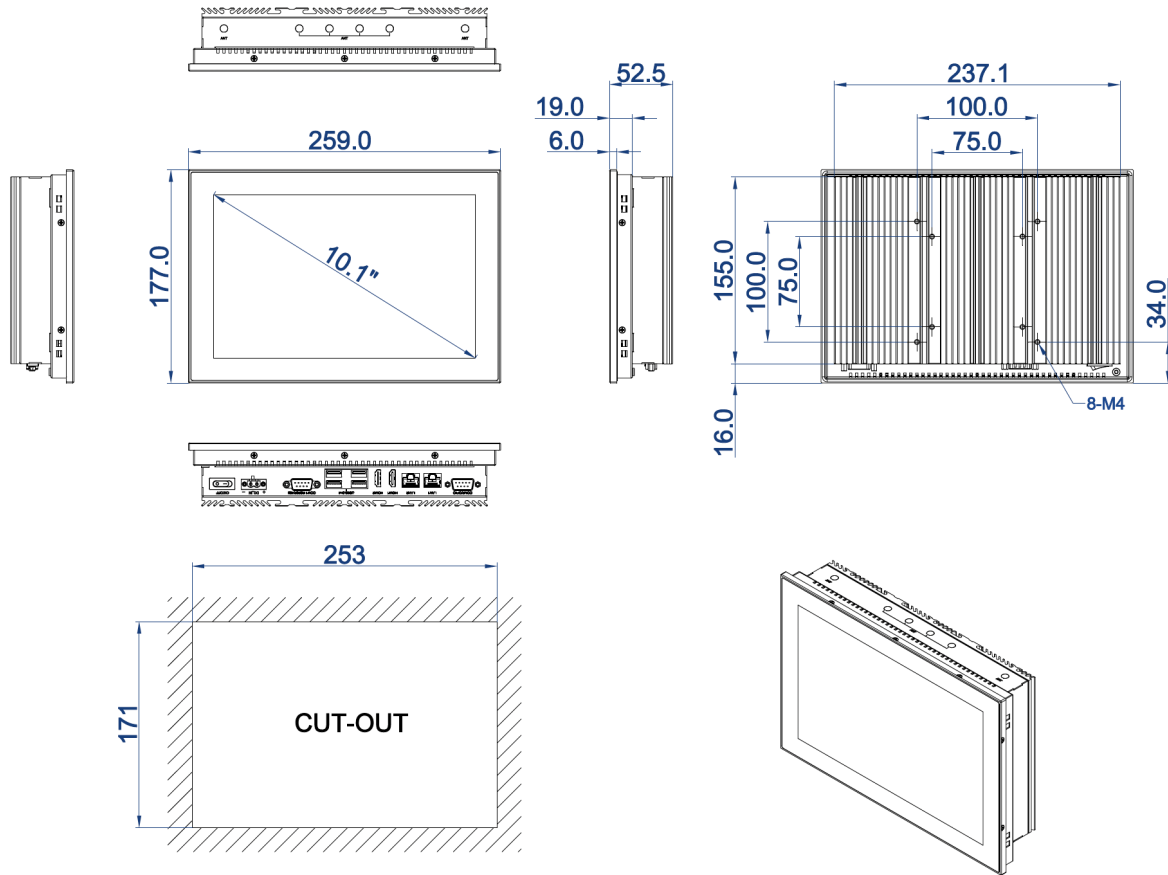

DIMENSIONS IN MILLIMETERS

TAICEM  
DATE:2023.11.23  
REV:A Unit:mm

**Ordering info.**

Part no.	Description
TPC-DCS101A1	10.1", 1280 * 800, Celeron J3455, Quad-core 1.5Ghz, Pcap. touch, 2*GLAN, 4*USB3.0, 2*COM, 2*HDMI, DC 12V, PSU
TPC-DCS101A1W	10.1", 1280 * 800, Celeron J3455, Quad-core 1.5Ghz, Pcap. touch, 2*GLAN, 4*USB3.0, 2*COM, 2*HDMI, DC 9~36V, No PSU by default
Memory	SO-DIMM, DDR3L, 4GB/8GB Memory
Storage	M.2 SSD: 128GB/256GB/512GB
Wireless Modules	Wi-Fi module, with Antenna (M.2 interface) Wi-Fi with BT integrated module, with Antenna (M.2 interface) All network 4G/LTE module, With Antenna (M.2 interface) 5G module, with Antenna (M.2 interface)
Power supply	Optional PSU for TPC-DCS101A1W
SIM Card module	Sim Card slot for 3G/4G/5G wireless function

**Packing List**

■ 1x Standard Product
■ 1x 60W PSU (Power Supply)
■ 1x Power cable & Plug
■ 8x Panel mount metal clips