

MINIATURE LOAD BUTTON W/ THREADED MOUNTING HOLES

Drawing Number: F11057			
INCH [mm]		R.O.= Rated Output	
WIRING CODE (WC1)			
+Excitation	-Excitation	+Signal	-Signal
RED	BLACK	GREEN	WHITE

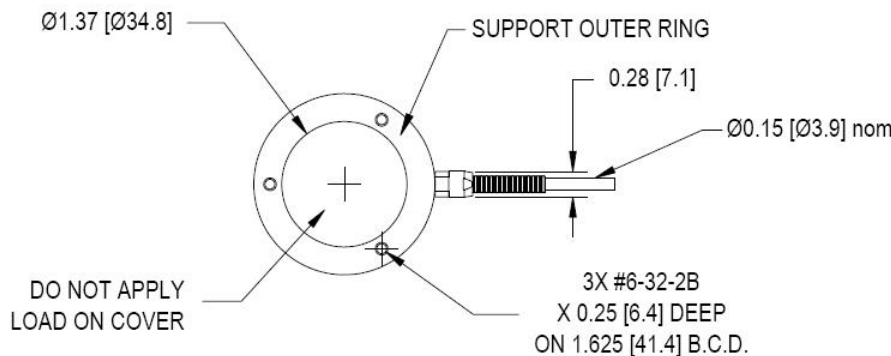
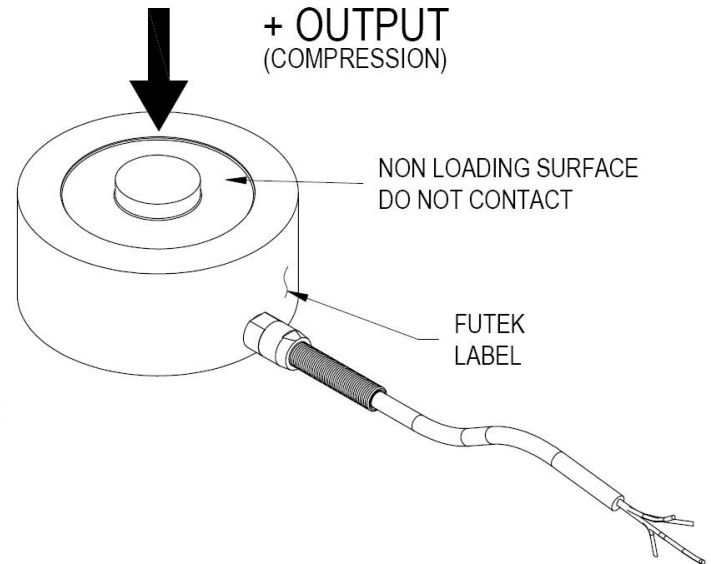
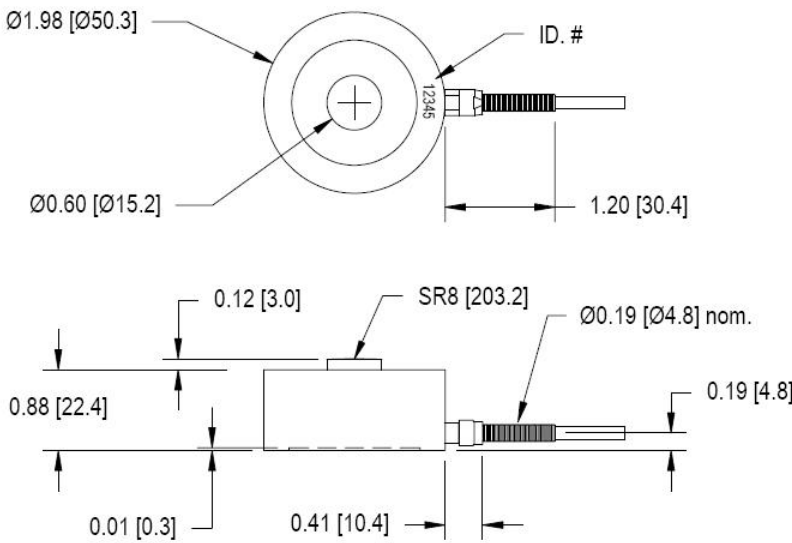

SPECIFICATIONS:

RATED OUTPUT	2 mV/V nom.
SAFE OVERLOAD	150% of R.O.
ZERO BALANCE	±3% of R.O.
EXCITATION (VDC OR VAC)	18 MAX
BRIDGE RESISTANCE	700 Ω nom.
NONLINEARITY	±0.5% of R.O.
HYSTERESIS	±0.5% of R.O.
NONREPEATABILITY	±0.1% of R.O.
TEMP. SHIFT ZERO	±0.01% of R.O./°F [0.018% of R.O./°C]
TEMP. SHIFT SPAN	±0.02% of LOAD/°F [0.036% of LOAD/°C]
COMPENSATED TEMP.	60 to 160°F [15 to 72°C]
OPERATING TEMP.	-60 to 200°F [-50 to 93°C]
DEFLECTION	0.0027 [0.07] to 0.0037 [0.09] nom.
MATERIAL	17-4PH S.S.
CABLE:	#24 AWG, 4 Conductor, Braided Shield Teflon Cable 10 ft [3m] Long
ACCESSORIES AND RELATED INSTRUMENTS AVAILABLE	
CALIBRATION (STD)	5 pt. COMPRESSION; 100K Ω SHUNT CAL. VALUE
CALIBRATION TEST EXCITATION	10 VDC

STK #	CAPACITIES	
	lb	N
FSH00883	15k	66720
FSH00884	20k	88960
FSH00885	30k	233440