

Product Features:

- Keeps the tablet securely fastened on moving vehicles
- Anti-theft design with key lockable cradle
- Wide power voltage input (9~36V DC-in)
- IP52 design (Rain proof)
- VESA standard for various standard fixtures

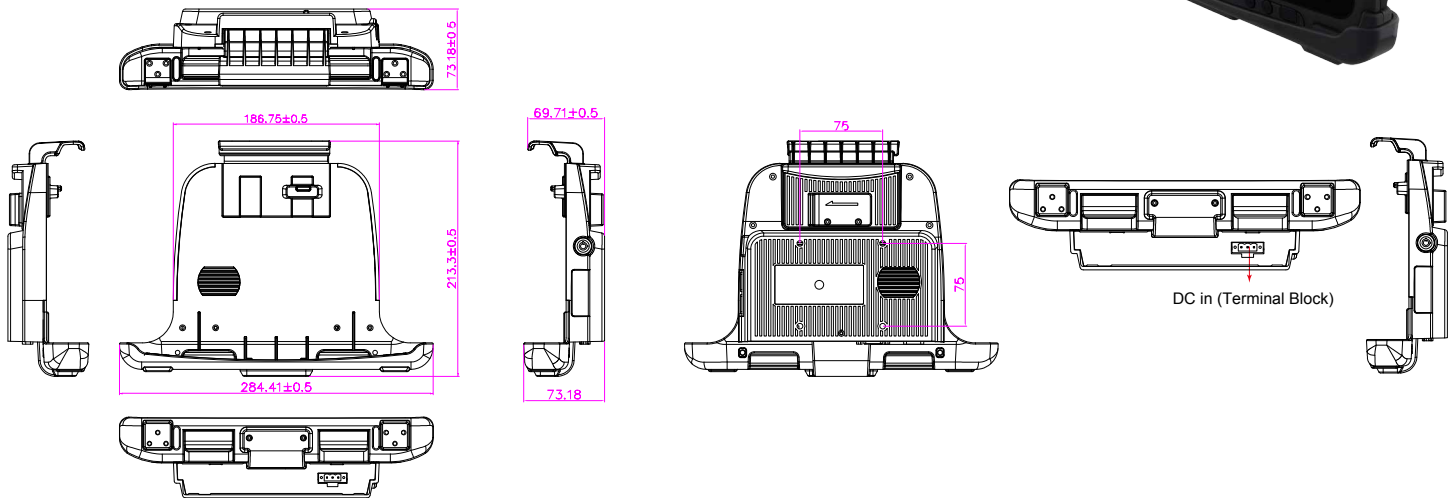

Mechanical Drawing



One hand docking :



1 Insert the Tablet PC into the docking

2. Push down the hook, the lock will lock automatically

One hand undocking :



1.Slide the latch to open the hook

2.Remove the Tablet from docking

Specification

Dimension	284.41 x 213.3 x 73.18 mm
Power Input	9~36V DC In
Mounting	75 x 75mm VESA Mount
Vibration	MIL STD. 810G, 5 ~ 500Hz, 2.24G